



Thank you for purchasing LG Variable Frequency Drives!

SAFETY INSTRUCTIONS

- Always follow safety instructions to prevent accidents and potential hazards from occurring.
- In this manual, safety messages are classified as follows:

 **WARNING** Improper operation may result in serious personal injury or death.

 **CAUTION** Improper operation may result in slight to medium personal injury or property damage.

- Throughout this manual we use the following two illustrations to make you aware of safety considerations:



Identifies potential hazards under certain conditions.
Read the message and follow the instructions carefully.



Identifies shock hazards under certain conditions.
Particular attention should be directed because dangerous voltage may be present.

- Keep operating instructions handy for quick reference.
- Read this manual carefully to maximize the performance of SV-iG5A series inverter and ensure its safe use.

WARNING

- **Do not remove the cover while power is applied or the unit is in operation.**
Otherwise, electric shock could occur.
- **Do not run the inverter with the front cover removed.**
Otherwise, you may get an electric shock due to high voltage terminals or charged capacitor exposure.
- **Do not remove the cover except for periodic inspections or wiring, even if the input power is not applied.**
Otherwise, you may access the charged circuits and get an electric shock.

- **Wiring and periodic inspections should be performed at least 10 minutes after disconnecting the input power and after checking the DC link voltage is discharged with a meter (below DC 30V).**

Otherwise, you may get an electric shock.

- **Operate the switches with dry hands.**

Otherwise, you may get an electric shock.

- **Do not use the cable when its insulating tube is damaged.**

Otherwise, you may get an electric shock.

- **Do not subject the cables to scratches, excessive stress, heavy loads or pinching.**

Otherwise, you may get an electric shock.



CAUTION

- **Install the inverter on a non-flammable surface. Do not place flammable material nearby.**

Otherwise, fire could occur.

- **Disconnect the input power if the inverter gets damaged.**

Otherwise, it could result in a secondary accident and fire.

- **After the input power is applied or removed, the inverter will remain hot for a couple of minutes.**

Otherwise, you may get bodily injuries such as skin-burn or damage.

- **Do not apply power to a damaged inverter or to an inverter with parts missing even if the installation is complete.**

Otherwise, electric shock could occur.

- **Do not allow lint, paper, wood chips, dust, metallic chips or other foreign matter into the drive.**

Otherwise, fire or accident could occur.

OPERATING PRECAUTIONS

(1) Handling and installation

- Handle according to the weight of the product.
- Do not stack the inverter boxes higher than the number recommended.
- Install according to instructions specified in this manual.
- Do not open the cover during delivery.
- Do not place heavy items on the inverter.
- Check the inverter mounting orientation is correct.
- Do not drop the inverter, or subject it to impact.
- Follow your national electrical code for grounding. Recommended Ground impedance for 200 V Class is below 100 ohm and for 400V class below 10 ohm.
- iG5A series contains ESD (Electrostatic Discharge) sensitive parts. Take protective measures against ESD before touching the pcb for inspection or installation.
- Use the inverter under the following environmental conditions:

Environment	Ambient temperature	- 10 ~ 50 (non-freezing)
	Relative humidity	90% RH or less (non-condensing)
	Storage temperature	- 20 ~ 65
	Location	Protected from corrosive gas, combustible gas, oil mist or dust
	Altitude, Vibration	Max. 1,000m above sea level, Max. 5.9m/sec ² (0.6G) or less
	Atmospheric pressure	70 ~ 106 kPa

(2) Wiring

- Do not connect a power factor correction capacitor, surge suppressor, or RFI filter to the output of the inverter.
- The connection orientation of the output cables U, V, W to the motor will affect the direction of rotation of the motor.
- Incorrect terminal wiring could result in the equipment damage.
- Reversing the polarity (+/-) of the terminals could damage the inverter.
- Only authorized personnel familiar with LG inverter should perform wiring and inspections.
- Always install the inverter before wiring. Otherwise, you may get an electric shock or have bodily injury.

(3) Trial run

- Check all parameters during operation. Changing parameter values might be required depending on the load.

- Always apply permissible range of voltage to the each terminal as indicated in this manual. Otherwise, it could lead to inverter damage.

(4) Operation precautions

- When the Auto restart function is selected, stay away from the equipment as a motor will restart suddenly after an alarm stop.
- The Stop key on the keypad is valid only when the appropriate function setting has been made. Prepare an emergency stop switch separately.
- If an alarm reset is made with the reference signal present, a sudden start will occur. Check that the reference signal is turned off in advance. Otherwise an accident could occur.
- Do not modify or alter anything inside the inverter.
- Motor might not be protected by electronic thermal function of inverter.
- Do not use a magnetic contactor on the inverter input for frequent starting/stopping of the inverter.
- Use a noise filter to reduce the effect of electromagnetic interference. Otherwise nearby electronic equipment may be affected.
- In case of input voltage unbalance, install AC reactor. Power Factor capacitors and generators may become overheated and damaged due to potential high frequency noise transmitted from inverter.
- Use an insulation-rectified motor or take measures to suppress the micro surge voltage when driving 400V class motor with inverter. A micro surge voltage attributable to wiring constant is generated at motor terminals, and may deteriorate insulation and damage motor.
- Before operating unit and prior to user programming, reset user parameters to default settings.
- Inverter can easily be set to high-speed operations, Verify capability of motor or machinery prior to operating unit.
- Stopping torque is not produced when using the DC-Break function. Install separate equipment when stopping torque is needed.

(5) Fault prevention precautions

- Provide a safety backup such as an emergency brake which will prevent the machine and equipment from hazardous conditions if the inverter fails.

(6) Maintenance, inspection and parts replacement

- Do not conduct a megger (insulation resistance) test on the control circuit of the inverter.
- Refer to Chapter 14 for periodic inspection (parts replacement).

(7) Disposal

- Handle the inverter as an industrial waste when disposing of it.

(8) General instructions

Many of the diagrams and drawings in this instruction manual show the inverter without a circuit breaker, a cover or partially open. Never run the inverter like this. Always place the cover with circuit breakers and follow this instruction manual when operating the inverter.

Important User Information

- The purpose of this manual is to provide the user with the necessary information to install, program, start up and maintain the SV-iG5A series inverter.
- To assure successful installation and operation, the material presented must be thoroughly read and understood before proceeding.
- This manual contains...

Chapter	Title	Description
1	Basic information & precautions	Provides general information and precautions for safe use of the SV-iG5A series inverter.
2	Installation	Provides instructions on how to install the SV-iG5A inverter.
3	Wiring	Provides instructions on how to wire the SV-iG5A inverter.
4	Basic configuration	Describes how to connect the optional peripheral devices to the inverter.
5	Programming keypad	Illustrates keypad features and display.
6	Basic operation	Provides instructions for quick start of the inverter.
7	Function list	Parameter values are listed.
8	Control block diagram	Shows control flow to help users easily understand operation mode.
9	Basic functions	Provides information for basic functions in the SV-iG5A
10	Advanced functions	Indicates advanced functions used for system application.
11	Monitoring	Gives information on the operating status and fault information.
12	Protective functions	Outlines protective functions of the SV-iG5A.
13	RS 485	Provides specification of RS485 communication.
14	Troubleshooting & maintenance	Defines the various inverter faults and the appropriate action to take as well as general troubleshooting information.
15	Specifications	Gives information on Input/Output rating, control type and more details of the SV-iG5A inverter.
16	Options	Explains options including Remote keypad, Conduit, EMC filter, DB resistor.

Table of Contents

CHAPTER 1 - Basic information & precautions	1-1
1.1 Important precautions	1-1
1.2 Product Details.....	1-2
1.3 Product assembling & disassembling	1-3
CHAPTER 2 - Installation	2-1
2.1 Installation precautions	2-1
2.2 Dimensions	2-3
CHAPTER 3 - Wiring	3-1
3.1 Terminal wiring	3-1
3.2 Specifications for power terminal block wiring	3-3
3.3 Control terminal specification.....	3-5
3.4 PNP/NPN selection and connector for communication option.....	3-6
CHAPTER 4 - Basic configuration	4-1
4.1 Connection of peripheral devices to the inverter.....	4-1
4.2 Recommended MCCB, Earth leakage circuit breaker (ELB) and Magnetic contactor.....	4-2
4.3 Recommendable AC/DC Reactor	4-2
CHAPTER 5 - Programming Keypad	5-1
5.1 Keypad features	5-1
5.2 Alpha-numeric view on the LED keypad	5-2
5.3 Moving to other groups	5-3
5.4 How to change the codes in a group	5-5
5.5 Parameter setting.....	5-7
5.6 Monitoring of operation status.....	5-10
CHAPTER 6 - Basic operation	6-1
6.1 Frequency Setting and Basic Operation	6-1
CHAPTER 7 - Function list	7-1
CHAPTER 8 - Control block diagram	8-1
8.1 Frequency and Drive mode setting	8-2
8.2 Accel/Decel setting and V/F control	8-3
CHAPTER 9 - Basic Functions	9-1
9.1 Frequency mode	9-1
9.2 Multi-Step Frequency setting	9-7
9.3 Operating command setting method.....	9-8
9.4 Accel/Decel time and pattern setting.....	9-12
9.5 V/F control.....	9-17
9.6 Stop method select	9-20
9.7 Frequency limit.....	9-21
CHAPTER 10 - Advanced functions	10-1
10.1 DC brake.....	10-1
10.2 Jog operation	10-3

10.3 UP – DOWN.....	10-4
10.4 3-Wire	10-4
10.5 Dwell operation	10-5
10.6 Slip compensation.....	10-6
10.7 PID control	10-8
10.8 Auto-tuning.....	10-10
10.9 Sensorless Vector Control	10-11
10.10 Energy-saving operation	10-12
10.11 Speed search	10-13
10.12 Auto restart try.....	10-15
10.13 Operating sound select (Carrier frequency change).....	10-16
10.14 2 nd motor operation	10-16
10.15 Cooling fan control.....	10-18
10.16 Operating mode select when cooling fan trip occurs	10-19
10.17 Parameter read/write	10-20
10.18 Parameter Initialize / Lock.....	10-21
CHAPTER 11 - Monitoring	11-1
11.1 Operating status monitoring	11-1
11.2 Monitoring the I/O terminal.....	11-3
11.3 Monitoring fault condition	11-4
11.4 Analog Output	11-6
11.5 Multi-function output terminal (MO) and Relay (3AC)	11-7
11.6 Output terminal select at keypad-inverter communication error.....	11-12
CHAPTER 12 - Protective functions	12-1
12.1 Electronic Thermal	12-1
12.2 Overload Warning and trip	12-2
12.3 Stall prevention	12-3
12.4 Output phase loss protection	12-5
12.5 External trip signal	12-5
12.6 Inverter Overload	12-6
12.7 Frequency command loss.....	12-7
12.8 DB Resistor Enable Duty setting.....	12-9
CHAPTER 13 - RS485 communication	13-1
13.1 Introduction	13-1
13.2 Specification.....	13-1
13.3 Installation.....	13-2
13.4 Operation	13-3
13.5 Communication protocol (MODBUS-RTU)	13-4
13.6 Communication protocol (LG BUS).....	13-4
CHAPTER 14 - Troubleshooting & Maintenance.....	14-1
14.1 Protective functions.....	14-1
14.2 Fault remedy	14-3

14.3 Precautions for maintenance and inspection	14-6
14.4 Check points	14-6
14.5 Part replacements	14-6
CHAPTER 15 - Specifications.....	15-1
15.1 Technical data	15-1
15.2 Temperature Derating Information	15-3
CHAPTER 16 - Option	16-1
16.1 Remote keypad	16-1
16.2 Conduit option	16-1
16.3 EMC filter	16-1
16.4 Braking resistor	16-2
CHAPTER 17 - DECLARATION OF CONFORMITY	i

CHAPTER 1 - BASIC INFORMATION & PRECAUTIONS

1.1 Important precautions

Unpacking and inspection

- Inspect the inverter for any damage that may have occurred during shipping. To verify the inverter unit is the correct one for the application you need, check the inverter type, output ratings on the nameplate and the inverter is intact.



- ← Inverter Type
- ← Input power rating
- ← Output Power Rating
- ← Rated output current, frequency
- ← Inverter Capacity (HP/kW)
- ← Bar Code and Serial Number

SV	075	iG5A	-	2	NC		
LG Inverter	Motor rating		Series Name iG5A	Input power		Frame name	
	004	0.4 [kW]		2	Three Phase 200~230[V]	-	Forced cooling
	008	0.75 [kW]					
	015	1.5 [kW]					
	022	2.2 [kW]					
	037	3.7 [kW]		4	Three Phase 380~460[V]	NC	1Hp Natural convection
	040	4.0 [kW]					
	055	5.5 [kW]					
075	7.5 [kW]						

- Accessories
If you have found any discrepancy, damage, etc., contact your sales representative.

Preparations of instruments and parts required for operation

Instruments and parts to be prepared depend on how the inverter is operated. Prepare equipment and parts as necessary.

Installation

To operate the inverter with high performance for a long time, install the inverter in a proper place in the correct direction and with proper clearances

Wiring

Connect the power supply, motor and operation signals (control signals) to the terminal block. Note that incorrect connection may damage the inverter and peripheral devices

1.2 Product Details

- Appearance

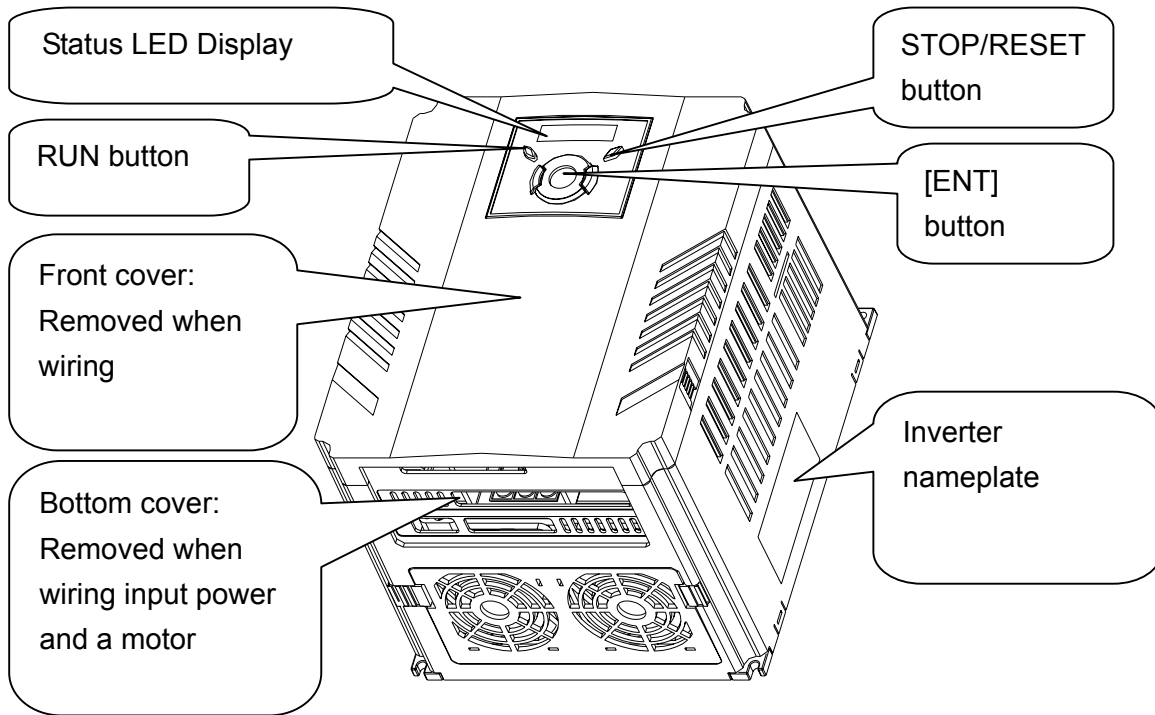

- Inside view after front cover is removed

Refer to “1.3 front cover removal” for details.

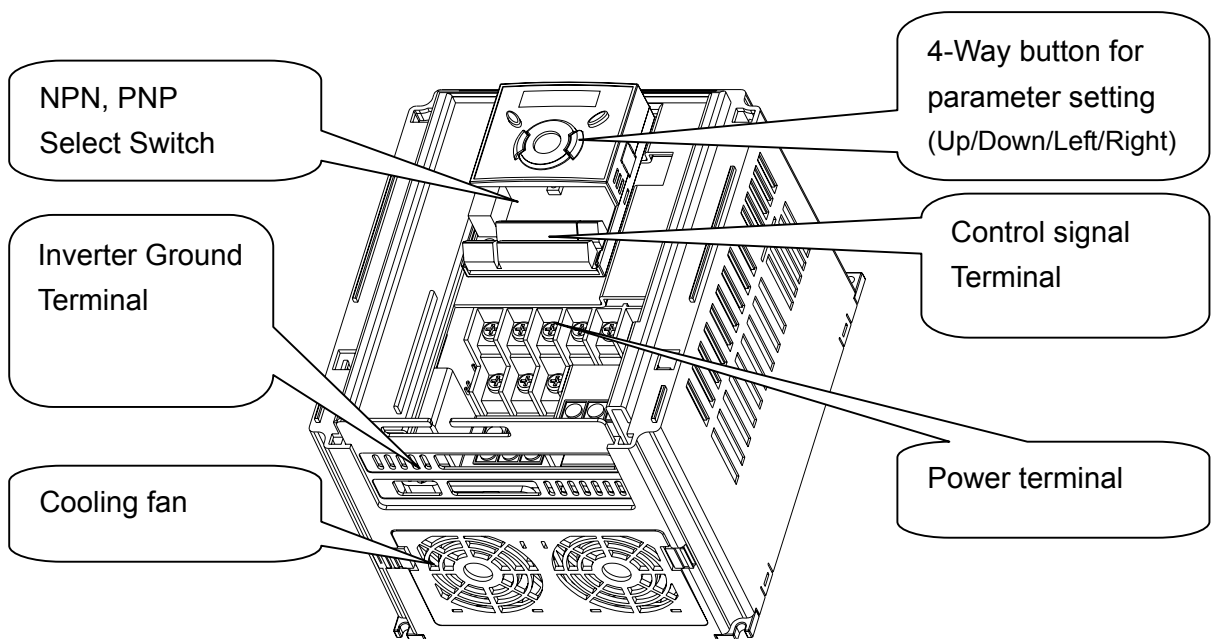

1.3 Product assembling & disassembling

- To remove the front cover: Press the both indented sides of the cover lightly and pull up.

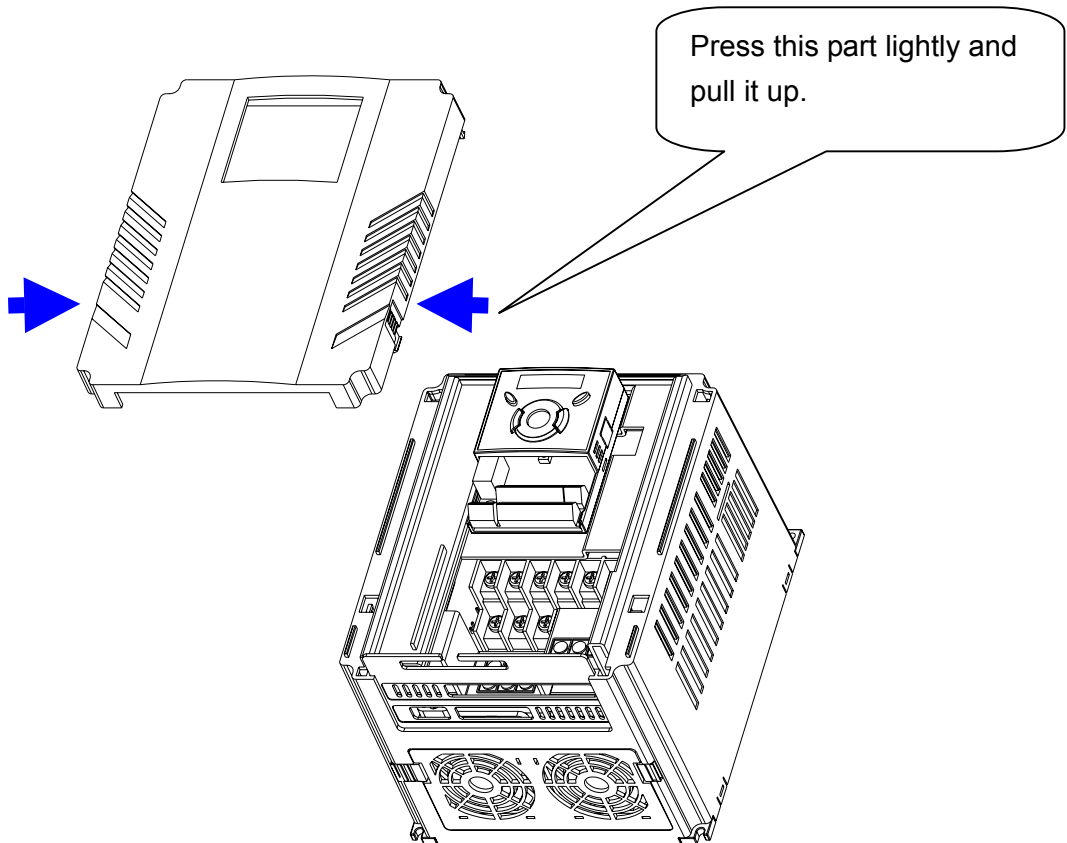

- To change the inverter fan: Press the both sides of bottom cover lightly and pull out to your side.

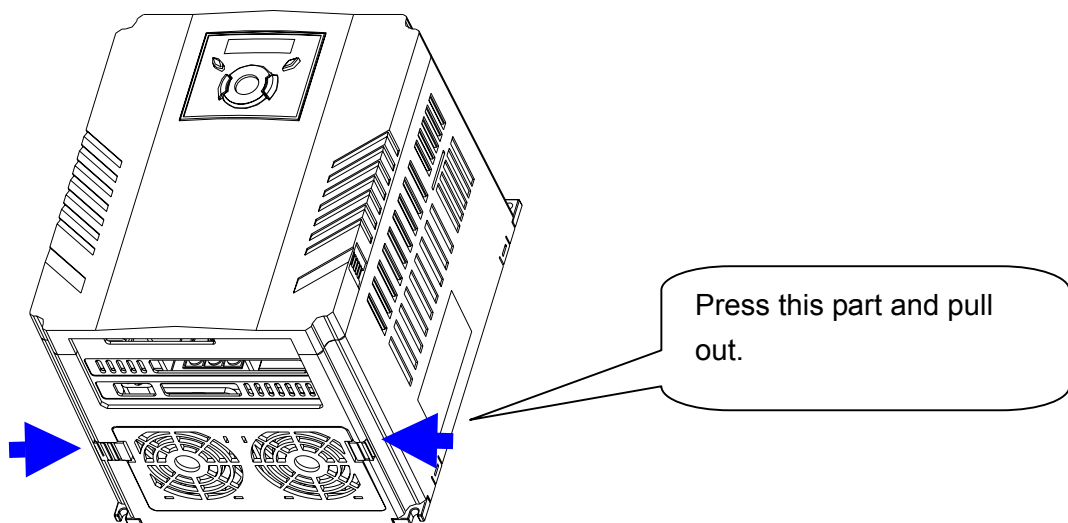

Notes:

CHAPTER 2 - INSTALLATION

2.1 Installation precautions

CAUTION

- Handle the inverter with care to prevent damage to the plastic components. Do not hold the inverter by the front cover. It may fall off.
- Install the inverter in a place where it is immune to vibration (5.9 m/s^2 or less).
- Install in a location where temperature is within the permissible range ($-10\sim 50^\circ\text{C}$).

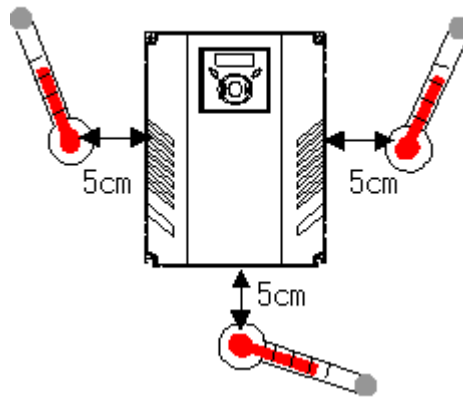

<Ambient Temp Checking Location>

- The inverter will be very hot during operation. Install it on a non-combustible surface.
- Mount the inverter on a flat, vertical and level surface. Inverter orientation must be vertical (top up) for proper heat dissipation. Also leave sufficient clearances around the inverter.

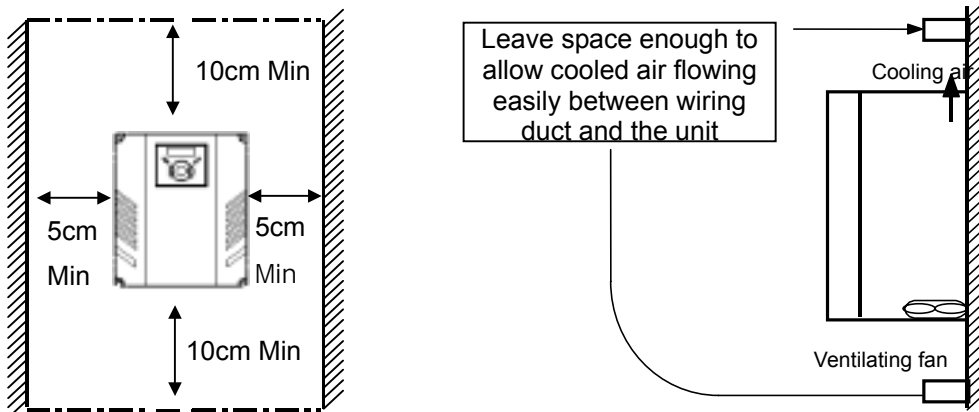

- Protect from moisture and direct sunlight.
- Do not install the inverter in any environment where it is exposed to waterdrops, oil mist, dust, etc. Install the inverter in a clean place or inside a "totally enclosed" panel any suspended matter is not entered.

- When two or more inverters are installed or a cooling fan is mounted in a panel, the inverters and fan must be installed in proper positions with extreme care to keep the ambient temperature below the permissible range.
- Installed the inverter using screws or bolts to insure the inverter is firmly fastened.

< For installing multiple inverters in a panel >

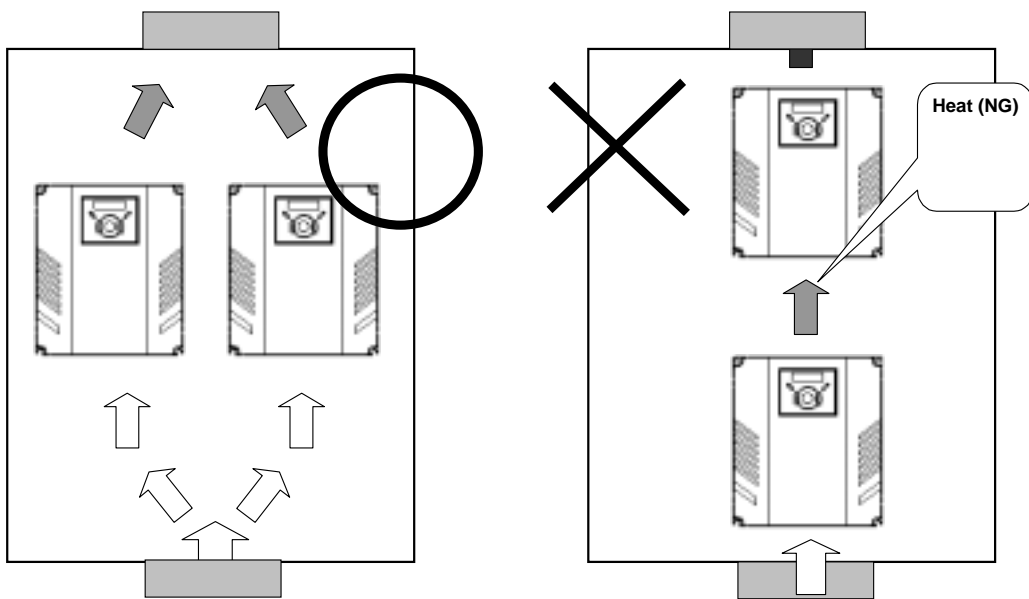

Note: Take caution on proper heat ventilation when installing inverters and fans in a panel.

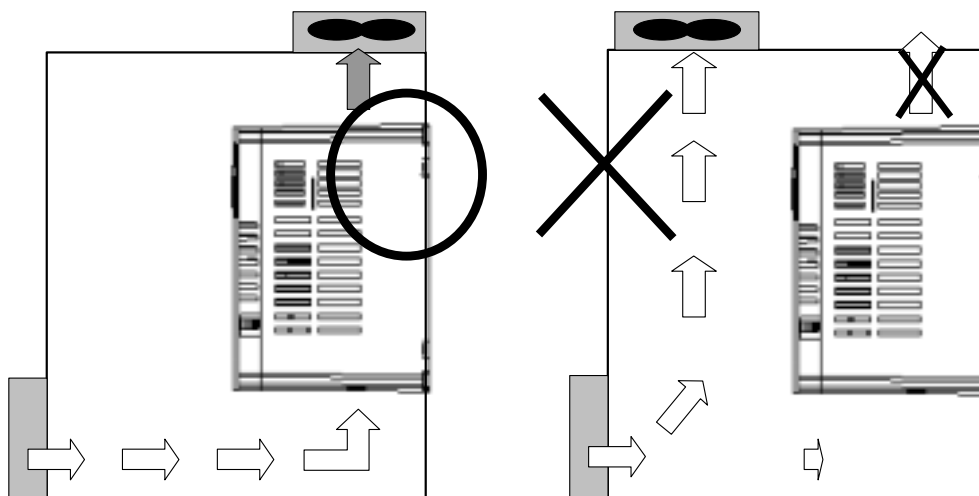

2.2 Dimensions

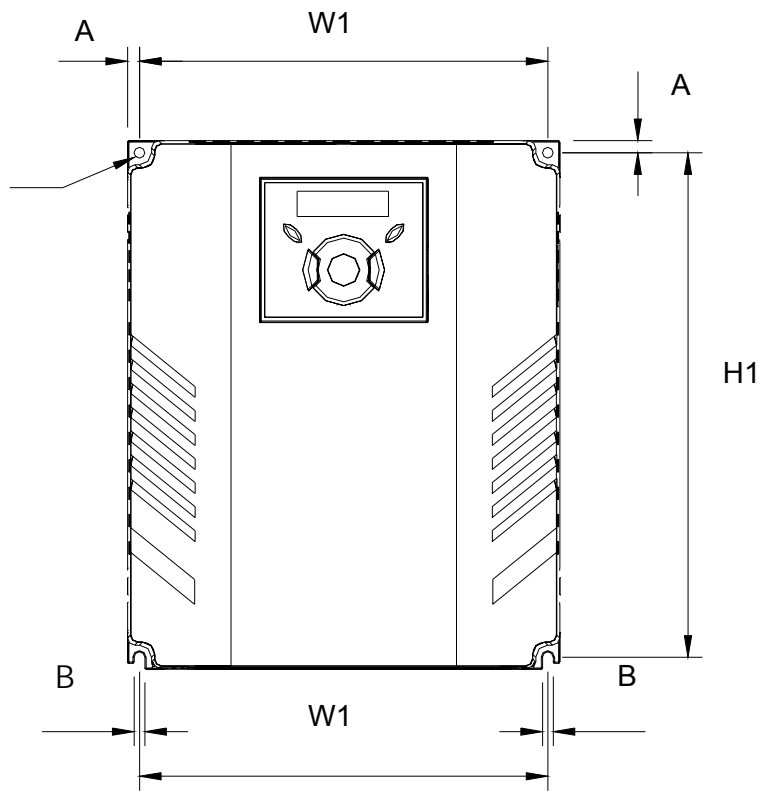
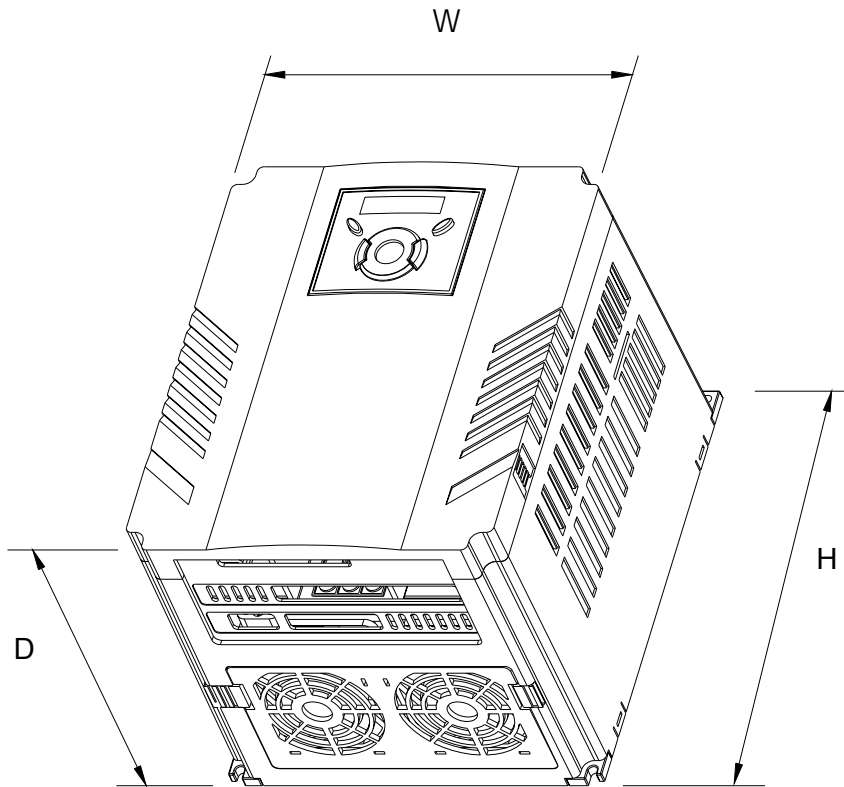

Inverter	[kW]	W [mm]	W1 [mm]	H [mm]	H1 [mm]	D [mm]		A [mm]	B [mm]	[Kg]
SV004iG5A-2										
SV008iG5A-2										
SV008iG5A-2NC										
SV015iG5A-2										
SV022iG5A-2										
SV037iG5A-2										
SV040iG5A-2										
SV055iG5A-2	5.5	180	170	220	210	170	4.5	5	4.5	3.66
SV075iG5A-2	7.5	180	170	220	210	170	4.5	5	4.5	3.66
SV004iG5A-4										
SV008iG5A-4										
SV008iG5A-4NC										
SV015iG5A-4										
SV022iG5A-4										
SV037iG5A-4										
SV040iG5A-4										
SV055iG5A-4	5.5	180	170	220	210	170	4.5	5	4.5	3.66
SV075iG5A-4	7.5	180	170	220	210	170	4.5	5	4.5	3.66

CHAPTER 3 - WIRING

3.1 Terminal wiring

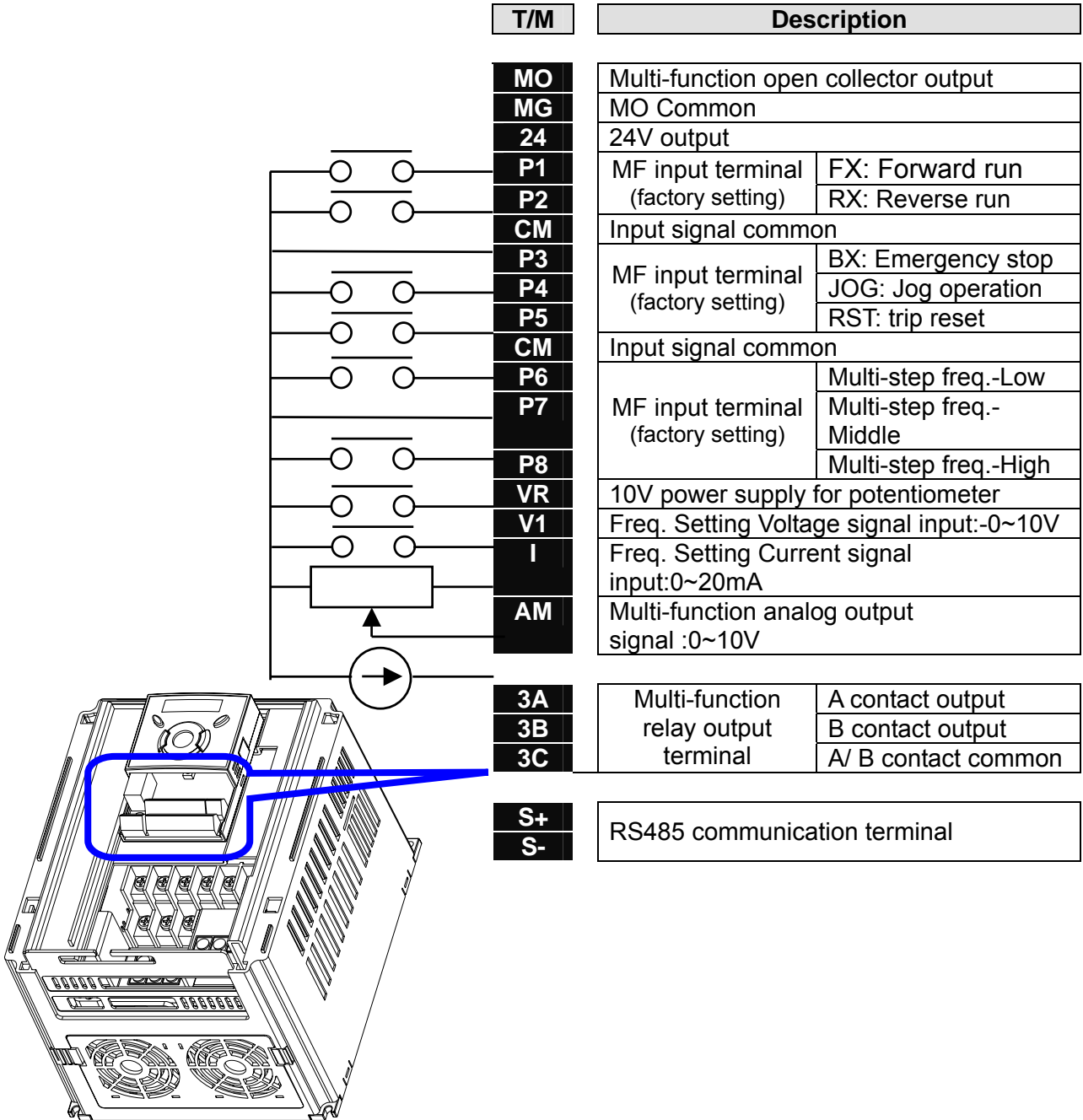

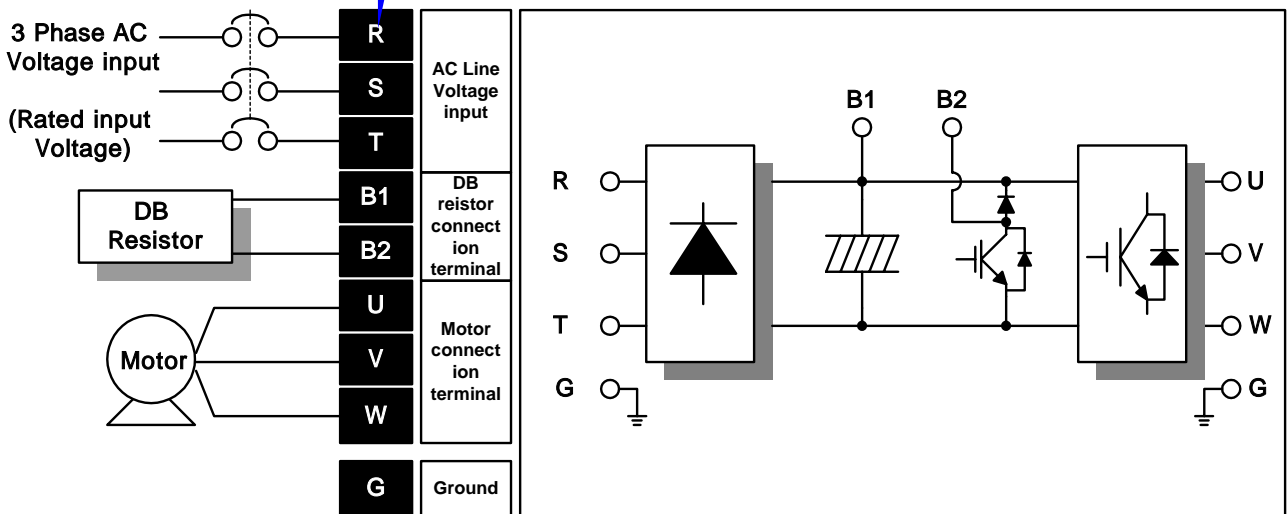
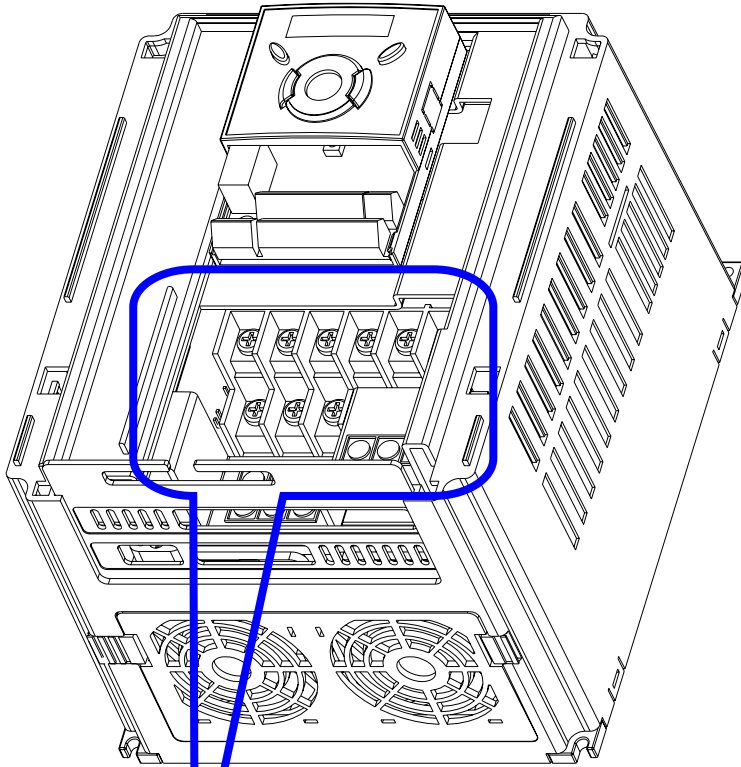

3.2 Specifications for power terminal block wiring

	Input wire size	Output wire size			Ground Wire			Screw size	Terminal torque
		B1		B2	U	V	W		
		R	S	T					
SV004iG5A-2									
SV008iG5A-2									
SV015iG5A-2									
SV022iG5A-2									
SV037iG5A-2									
SV040iG5A-2									
SV055iG5A-2	5.5 mm ²	5.5 mm ²		5.5 mm ²			M5	15Kgf · cm	
SV075iG5A-2	8 mm ²	8 mm ²		5.5 mm ²			M5	15Kgf · cm	
SV004iG5A-4									
SV008iG5A-4									
SV015iG5A-4									
SV022iG5A-4									
SV037iG5A-4									
SV040iG5A-4									
SV055iG5A-4	3.5 mm ²	2 mm ²		3.5 mm ²			M5	15Kgf · cm	
SV075iG5A-4	3.5 mm ²	3.5 mm ²		3.5 mm ²			M5	15Kgf · cm	

CAUTION

- Make sure the input power is off before wiring.
- When power supply is switched off following operation, wait at least 10 minutes after LED keypad display is off before you start working on it.
- Applying input power supply to the output terminals U, V and W causes internal inverter damage.
- Use ring terminals with insulated caps when wiring the input power and motor wiring.
- Do not leave wire fragments inside the inverter. Wire fragments can cause faults, breakdowns and malfunctions.
- Never short B1 and B2 terminals. Shorting terminals may cause internal inverter damage.
- Do not install a power factor capacitor, surge suppressor or RFI filters in the output side of the inverter. Doing so may damage these components.

⚠ WARNING

- Use the Type 3 grounding method (Ground impedance: Below 100Ω) for 230V class inverters.
- Use the Special Type 3 grounding method (Ground impedance: Below 10Ω) for 460V class inverters.
- Use the dedicated ground terminal to ground the inverter. Do not use the screw in the case or chassis, etc for grounding.

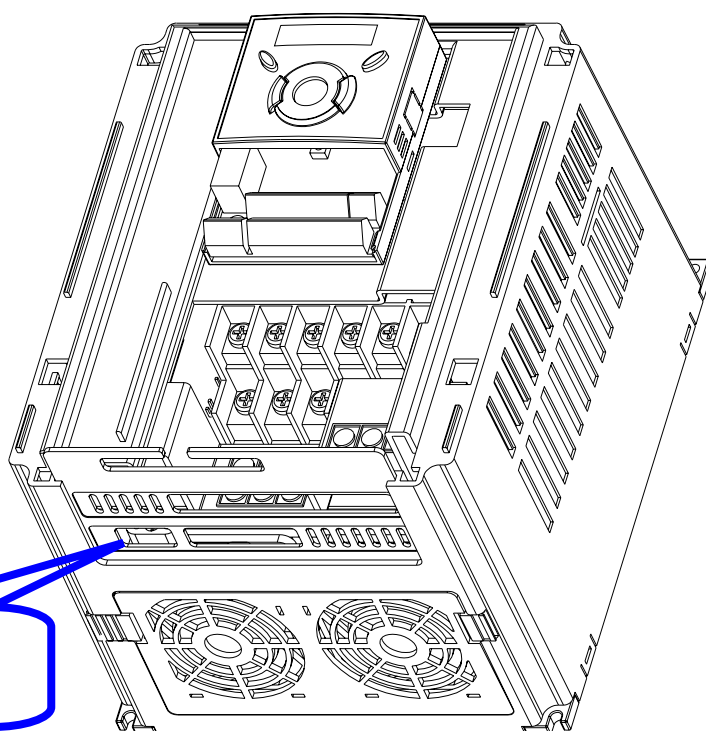

Opening to access
Ground Terminal

Note : Grounding procedure

- 1) Remove the front cover.
- 2) Connect the Grounding wire to the ground terminal through the opening for ground terminal as shown above. Enter the screw driver from vertical to the terminal and secure the screw tightly.

Note : Grounding work guidance

Inverter capacity	200V Class			400V Class		
	Wire size	Terminal screw	Grounding method	Wire size	Terminal screw	Grounding method
0.4 kW			Type 3			Special Type 3
0.75						
1.5 kW						
2.2~4.0 kW						
5.5~7.5 kW	5.5 mm ²	M4		3.5 mm ²	M4	

3.3 Control terminal specification

MO	MG	24	P1	P2	CM	P3	P4	S-	S+		
3A	3B	3C	P5	CM	P6	P7	P8	VR	V1	I	AM

T/M	Terminal Description	Wire size[mm ²]		Screw size	Torque [Nm]	Specification
		single wire	Stranded			
P1~P8	Multi-function input T/M 1-8	1.0	1.5	M2.6	0.4	
CM	Common Terminal	1.0	1.5	M2.6	0.4	
VR	Power supply for external potentiometer	1.0	1.5	M2.6	0.4	Output voltage: 12V Max output current: 100mA Potentiometer: 1 ~ 5kohm
V1	Input terminal for Voltage operation	1.0	1.5	M2.6	0.4	Max input voltage: -12V ~ +12V input
I	Input terminal for Current operation	1.0	1.5	M2.6	0.4	0 ~ 20mA input Internal resistor: 500 ohm
AM	Multi-function analog output terminal	1.0	1.5	M2.6	0.4	Max output voltage: 1[V] Max output current: 100mA
MO	Multi-function terminal for open collector	1.0	1.5	M2.6	0.4	Below DC 26V, 100mA
MG	Ground terminal for external power supply	1.0	1.5	M2.6	0.4	
24	24V External Power Supply	1.0	1.5	M2.6	0.4	Max output current: 100mA
3A	Multi-function relay output A contact	1.0	1.5	M2.6	0.4	Below AC 250V, 1A
3B	Multi-function relay output B contact	1.0	1.5	M2.6	0.4	Below DC 30V, 1A
3C	Common for Multi-function relays	1.0	1.5	M2.6	0.4	

Note 1) Tie the control wires more than 15cm away from the control terminals. Otherwise, it interferes front cover reinstallation.

Note 2) Use Copper wires rated 600V, 75 and higher.

Note 3) Use the recommended tightening torque when securing terminal screws.

Note 4) When you use external power supply (24V) for multi-function input terminal (P1~P8), terminals will be active above 12V level. Take caution not to drop the voltage below 12V.

3.4 PNP/NPN selection and connector for communication option

1. When using DC 24V inside inverter [NPN]

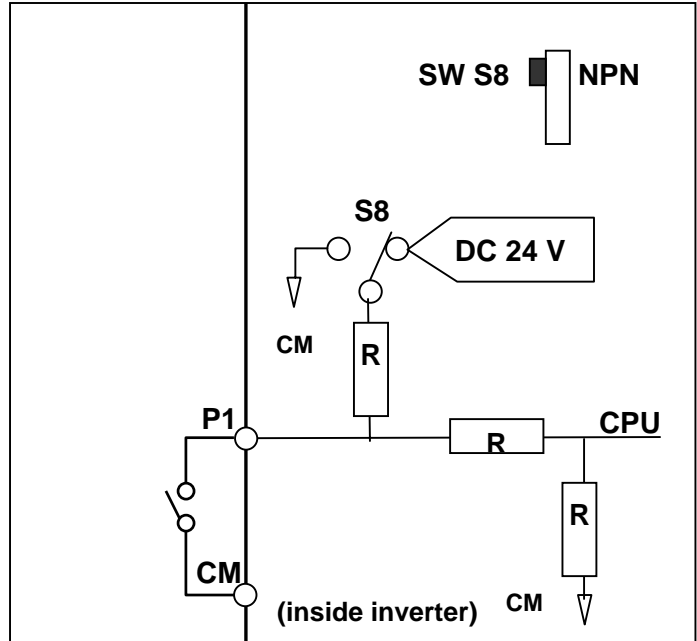
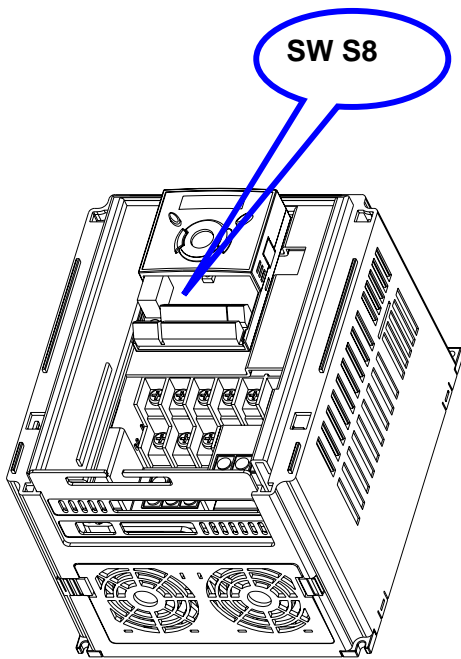

2. When using external DC 24V [PNP]

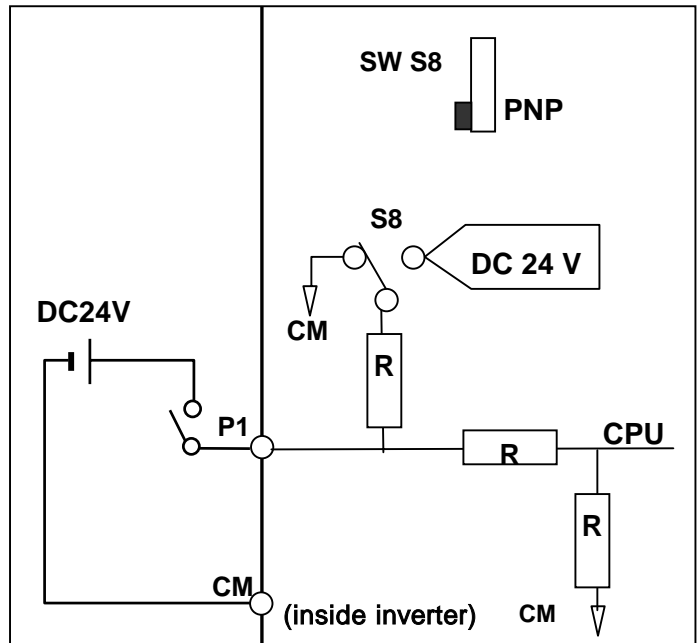

CHAPTER 4 - BASIC CONFIGURATION

4.1 Connection of peripheral devices to the inverter

The following devices are required to operate the inverter. Proper peripheral devices must be selected and correct connections made to ensure proper operation. An incorrectly applied or installed inverter can result in system malfunction or reduction in product life as well as component damage. You must read and understand this manual thoroughly before proceeding.

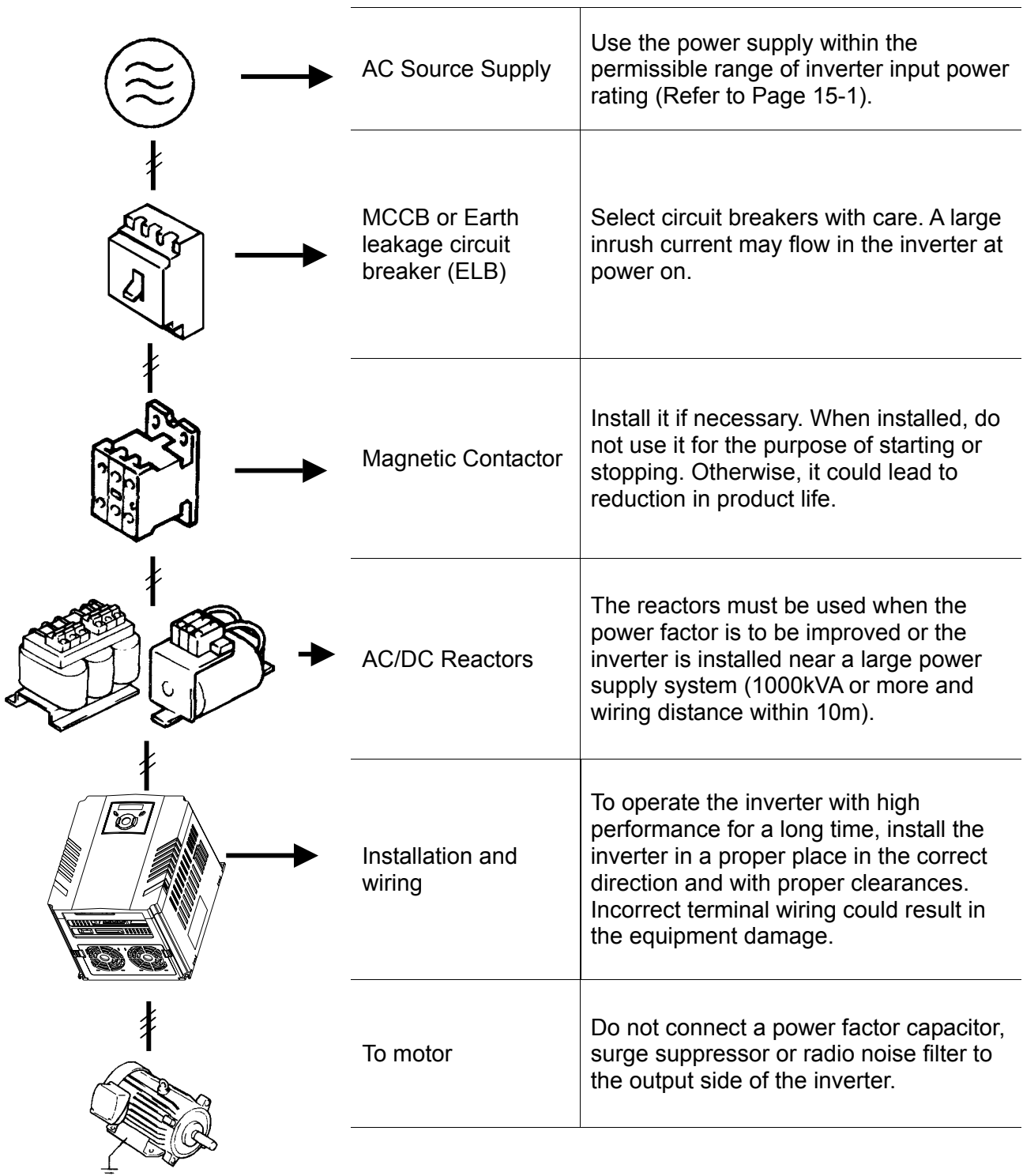

4.2 Recommended MCCB, Earth leakage circuit breaker (ELB) and Magnetic contactor

Model	MCCB/ ELB(LG)	Magnetic Contactor	Model	MCCB/ ELB(LG)	Magnetic Contactor
004iG5A-2			004iG5A-4		
008iG5A-2			008iG5A-4		
015iG5A-2			015iG5A-4		
022iG5A-2			022iG5A-4		
037iG5A-2			037iG5A-4		
040iG5A-2			040iG5A-4		
055iG5A-2	ABS53b,EBS53	GMC-22	055iG5A-4	ABS33b,EBS33	GMC-22
075iG5A-2	ABS103b,EBS103	GMC-32	075iG5A-4	ABS33b,EBS33	GMC-22

4.3 Recommendable AC/DC Reactor

Model	AC input fuse	AC reactor	DC reactor
004iG5A-2			
008iG5A-2			
015iG5A-2			
022iG5A-2			
037iG5A-2			
040iG5A-2			
055iG5A-2	40 A	0.39 mA,30A	1.37 mA,29A
075iG5A-2	50 A	0.28 mA,40A	1.05 mA,38A
004iG5A-4			
008iG5A-4			
015iG5A-4			
022iG5A-4			
037iG5A-4			
040iG5A-4			
055iG5A-4	20 A	1.22 mA,15A	5.34 mA,14A
075iG5A-4	30 A	1.14 mA,20A	4.04 mA,19A

CHAPTER 5 - PROGRAMMING KEYPAD

5.1 Keypad features

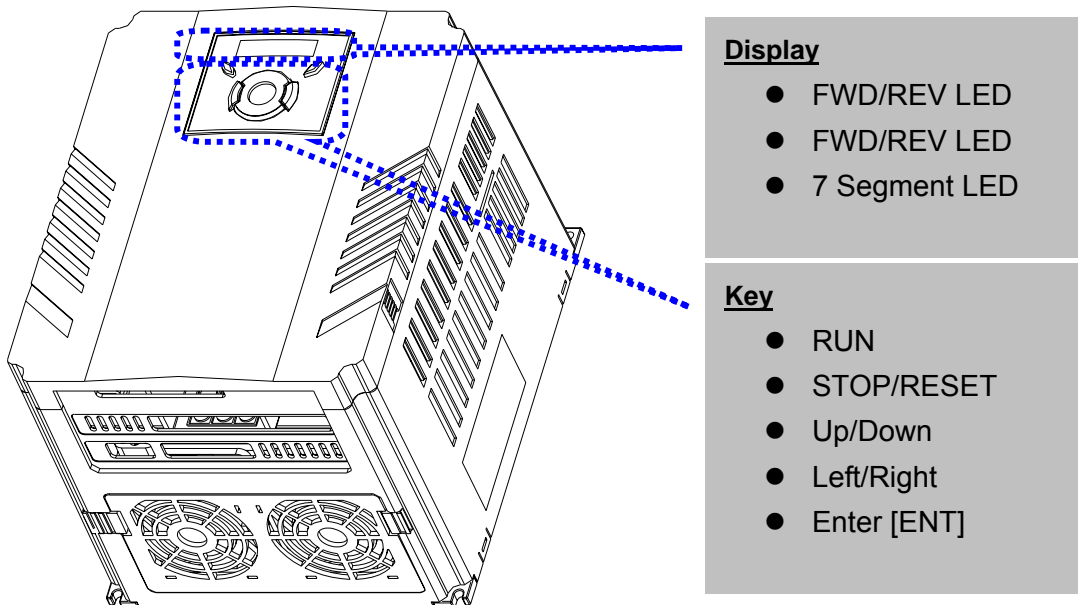

- Display**
- FWD/REV LED
 - FWD/REV LED
 - 7 Segment LED
- Key**
- RUN
 - STOP/RESET
 - Up/Down
 - Left/Right
 - Enter [ENT]

Display		
FWD/REV	Lit during forward run	Blinks when a fault occurs
REV	Lit during reverse run	
RUN	Lit during Operation	
SET	Lit during parameter setting	
7 segment	Displays operation status and parameter information	

Keys		
RUN	Run command	
STOP/RESET	STOP: Stop command during operation, RESET: Reset command when fault occurs.	
▲	UP	Used to scroll through codes or increase parameter value
▼	Down	Used to scroll through codes or decrease parameter value
◀	Left	Used to jump to other parameter groups or move a cursor to the left to change the parameter value
▶	Right	Used to jump to other parameter groups or move cursor to the right to change the parameter value
●	ENT	Used to set the parameter value or save the changed parameter value

5.2 Alpha-numeric view on the LED keypad

0	0	A	A	K	K	U	U
1	1	b	B	L	L	v	V
2	2	c	C	m	M	w	W
3	3	d	D	n	N	x	X
4	4	E	E	O	O	y	Y
5	5	F	F	P	P	z	Z
6	6	G	G	Q	Q		
7	7	H	H	R	R		
8	8	I	I	S	S		
9	9	J	J	T	T		

5.3 Moving to other groups

- There are 4 different parameter groups in SV- iG5A series as shown below.

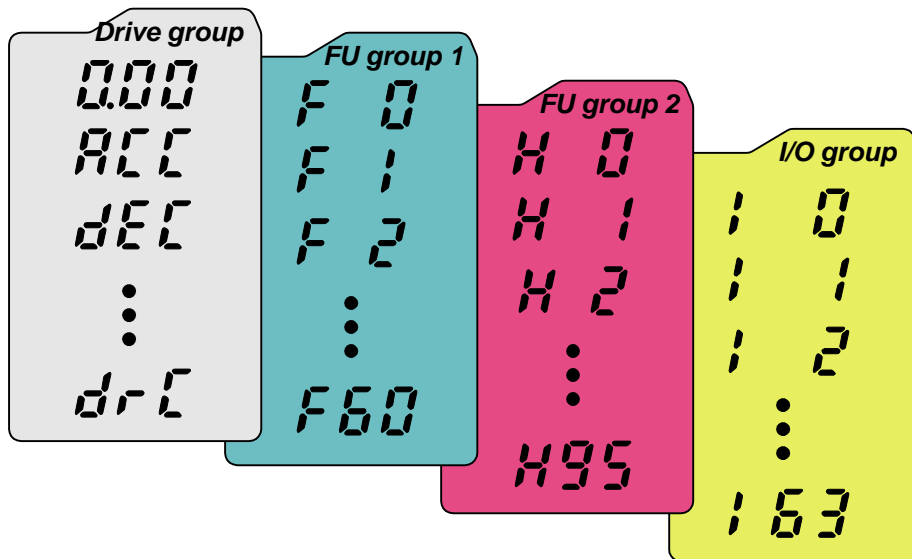

Drive group	Basic parameters necessary for the inverter to run. Parameters such as Target frequency, Accel/Decel time settable.
Function group 1	Basic function parameters to adjust output frequency and voltage.
Function group 2	Advanced function parameters to set parameters for such as PID Operation and second motor operation.
I/O (Input/Output) group	Parameters necessary to make up a sequence using Multi-function input/output terminal.

- Moving to other parameter groups** is only available in the first code of each group as the figure shown below.

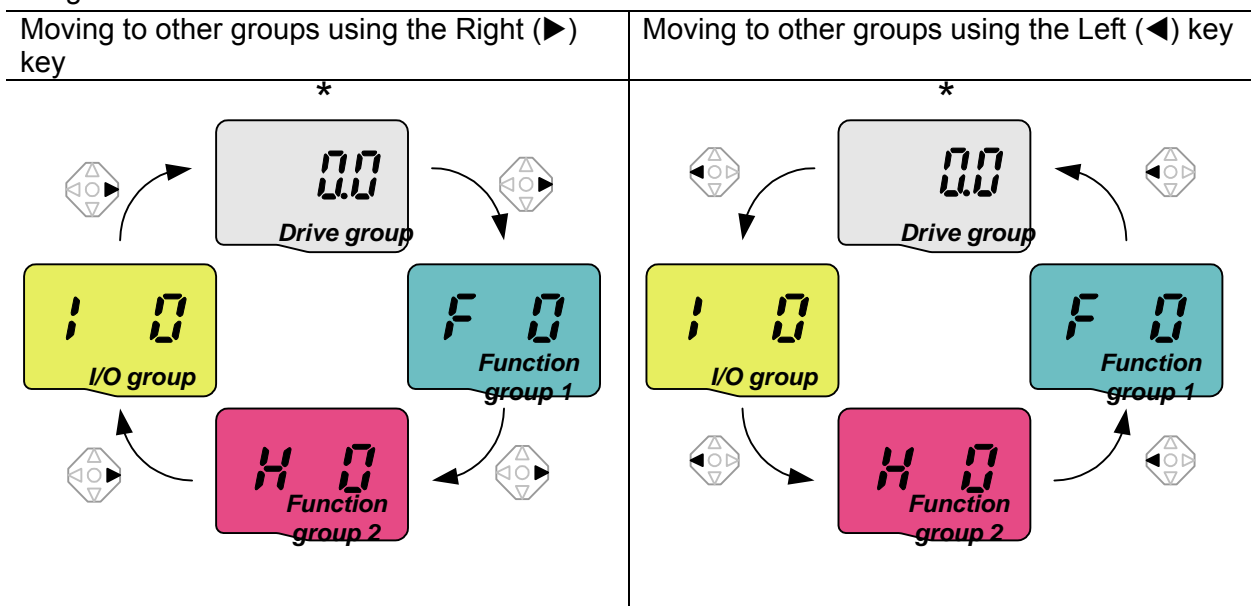

* Target frequency can be set at 0.0 (the 1st code of drive group). Even though the preset value is 0.0, it is user-settable. The changed frequency will be displayed after it is changed.

- How to move to other groups at the 1st code of each group

1		- The 1st code in Drive group “0.00” will be displayed when AC input power is applied. - Press the right arrow (▶) key once to go to Function group 1.
2		- The 1st code in Function group 1 “F 0” will be displayed. - Press the right arrow (▶) key once to go to Function group 2.
3		- The 1st code in Function group 2 “H 0” will be displayed. - Press the right arrow (▶) key once to go to I/O group.
4		- The 1st code in I/O group “I 0” will be displayed. - Press the right arrow (▶) key once again to return to Drive group.
5		- Return to the 1st code in Drive group “0.00” .

♣ If the left arrow key (◀) is used, the above will be executed in the reverse order.

- How to move to other groups from any codes other than the 1st code

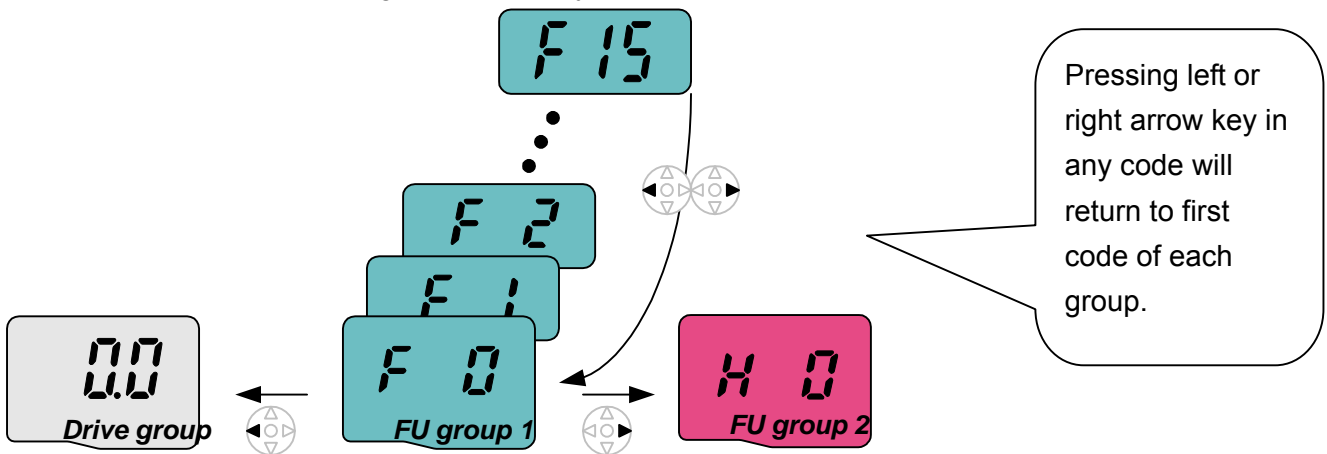

To move from the F 15 to function group 2

1		- In F 15, press the Left (◀) or Right arrow (▶) key. Pressing the key goes to the first code of the group.
2		- The 1 st code in function group 1 “F 0” is displayed. - Press the right arrow (▶) key.
3		- The 1 st code in function group 2 “H 0” will be displayed.

5.4 How to change the codes in a group

● Code change in Drive group

	1		- In the 1 st code in Drive group "0.00", press the Up (▲) key once.
	2		- The 2 nd code in Drive group "ACC" is displayed. - Press the Up (▲) key once.
	3		- The 3 rd code "dEC" in Drive group is displayed. - Keep pressing the Up (▲) key until the last code appears.
	4		- The last code in Drive group "drC" is displayed. - Press the Up (▲) key again.
	5		- Return to the first code of Drive group.
♣ Use Down (▼) key for the opposite order.			

● Code jump

When moving from the "F 0" to the "F 15" directly

	1		- Press the Ent (●) key in "F 0".
	2		- 1 (the code number of F1) is displayed. Use the Up (▲) key to set to 5.
	3		- "05" is displayed by pressing the Left (◀) key once to move the cursor to the left. The numeral having a cursor is displayed brighter. In this case, 0 is active. - Use the Up (▲) key to set to 1.
	4		- 15 is set. - Press the Ent (●) key once.
	5		- Moving to F 15 has been complete.

♣ Function group 2 and I/O group are settable with the same setting.

● Navigating codes in a group

When moving from F 1 to F 15 in Function group 1

	1		- In F 1, continue pressing the Up (▲) key until F15 is displayed.
	2		- Moving to F15 has been complete.
♣ The same applies to Function group 2 and I/O group.			

♣ Note: Some codes will be skipped in the middle of increment (▲)/decrement (▼) for code change. That is because it is programmed that some codes are intentionally left blank for future use or the codes user does not use are invisible.

For example, when F24 [High/low frequency limit select] is set to “O (No)”, F25 [High frequency limit] and F26 [Low frequency limit] are not displayed during code change. But When F24 is set to “1(Yes)”, F25 and F26 will appear on the display.

5.5 Parameter setting

- Changing parameter values in Drive Group

When changing ACC time from 5.0 sec to 16.0 sec

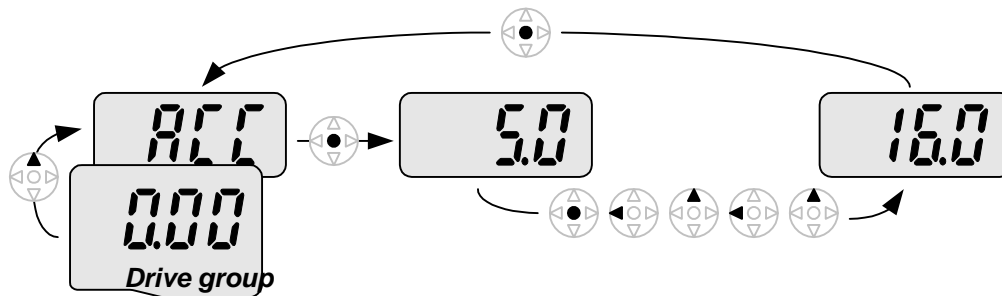

1		- In the first code "0.00", press the Up (▲) key once to go to the second code.
2		- ACC [Accel time] is displayed. - Press the Ent key (●) once.
3		- Preset value is 5.0, and the cursor is in the digit 0. - Press the Left (◀) key once to move the cursor to the left.
4		- The digit 5 in 5.0 is active. Then press the Up (▲) key once.
5		- The value is increased to 6.0 - Press the Left (◀) key to move the cursor to the left.
6		- 0.60 is displayed. The first 0 in 0.60 is active. - Press the Up (▲) key once.
7		- 16.0 is set. - Press the Ent (●) key once. - 16.0 is blinking. - Press the Ent (●) key once again to return to the parameter name.
8		- ACC is displayed. Accel time is changed from 5.0 to 16.0 sec.

In step 7, pressing the Left (◀) or Right (▶) key while 16.0 is blinking will disable the setting.

Note 1) Pressing the Left (◀)/ Right (▶) /Up (▲) /Down (▼) key while cursor is blinking will cancel the parameter value change. Pressing the Enter key (●) in this status will enter the value into memory.

● Frequency setting

When changing run frequency to 30.05 Hz in Drive group

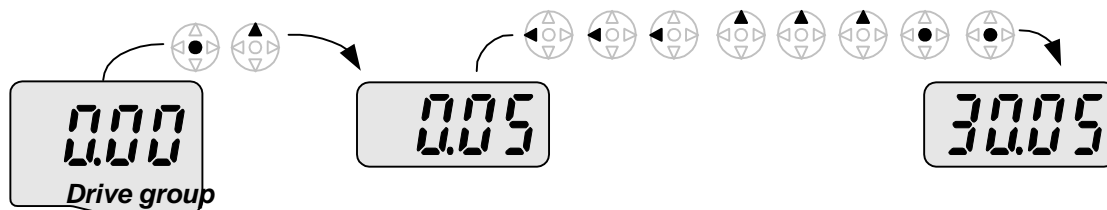

1		- In "0.00", press the Ent (●) key once.
2		- The second decimal 0 becomes active. - Press the UP (▲) key until 5 is displayed.
3		- Press the Left (◀) key once.
4		- The first decimal 0 becomes active. - Press the Left (◀) key once.
5		- Press the Left (◀) key once.
6		- Set 3 using UP (▲) key.
7		- Press the Ent (●) key. - 30.05 is blinking. - Press the Ent (●) key.
8		- 30.05 is entered into memory.

♣ SV-iG5A display can be extended to 5 digits using left (◀)/right (▶) keys.

♣ Parameter setting is disabled when pressing other than Enter Key in step 7.

● Changing parameter value in Input/Output group

When changing the parameter value of F 27 from 2 to 5

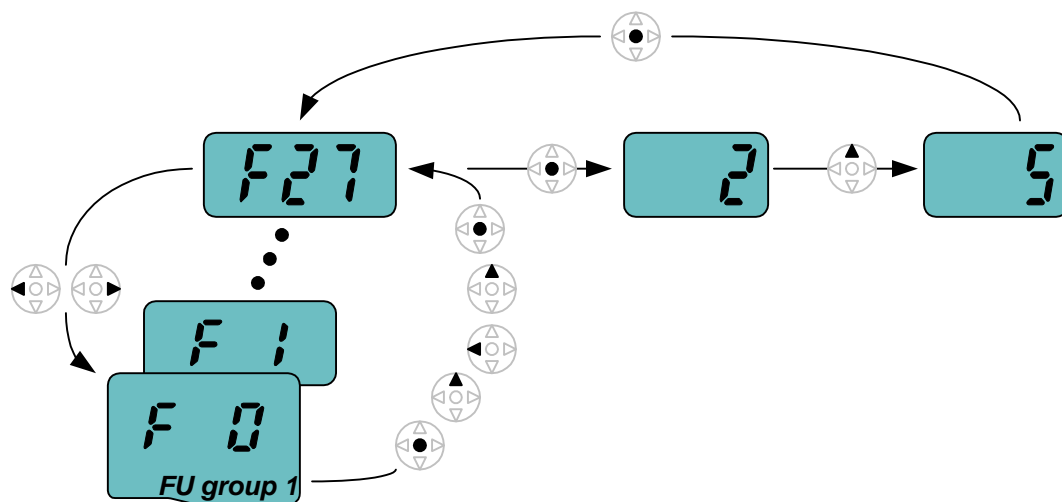

1		- In F0, press the Ent (●) key once.
2		- Check the present code number. - Increase the value to 7 by pressing the Up (▲) key.
3		- When 7 is set, press the Left (◀) key once.
4		- 0 in 07 is active. - Increase the value to 2 by pressing the Up (▲) key.
5		- 27 is displayed - Press the Ent (●) key once.
6		- The parameter number F27 is displayed. - Press the Ent (●) key once to check the set value.
7		- The preset value 2 is displayed. - Increase the value to 5 using UP key (▲).
8		- Press the Ent (●) key.
9		- Code number will appear after 5 is blinking. Parameter change is complete. - Press either Left (◀) or Right (▶) keys.
10		- Moving to first code of Function group 1 is complete.

♣ The above setting is also applied to change parameter values in function group 2 and I/O group.

5.6 Monitoring of operation status

- Output current display

Monitoring output current in Drive group

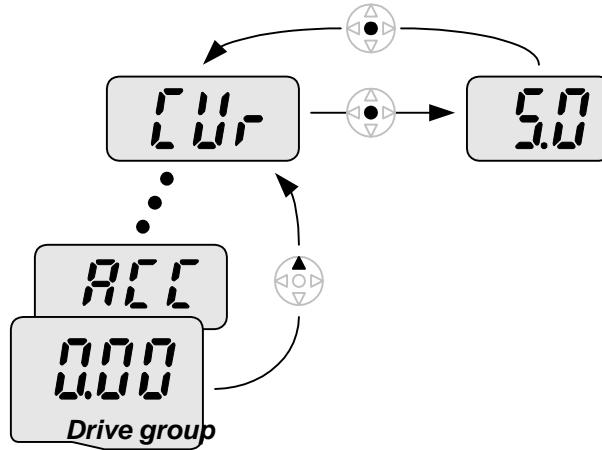

1		- In [0.0], continue pressing the Up (▲) or Down (▼) key until [Cur] is displayed.
2		- Monitoring output current is provided in this parameter. - Press the Enter (●) key once to check the current.
3		- Present output current is 5 A. - Press the Enter (●) key once to return to the parameter name.
4		- Return to the output current monitoring code.

♣ Other parameters in Drive group such as dCL (Inverter DC link current) or vOL (Inverter output voltage) can be monitored via the same method.

● Fault display

How to monitor fault condition in Drive group

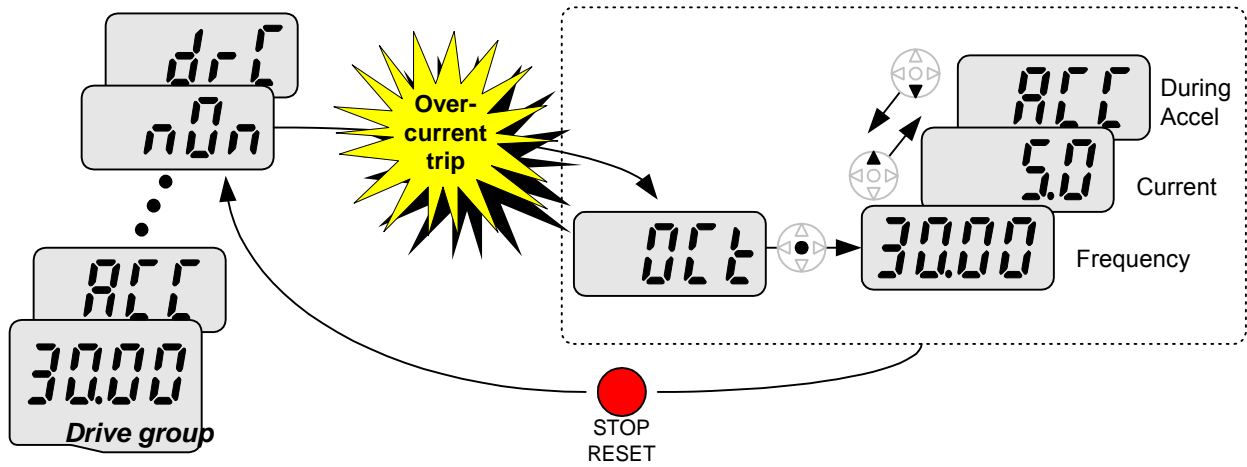

1		- This message appears when an Overcurrent fault occurs. - Press the Enter (●) key or UP/Down key once.
2		- The run frequency at the time of fault (30.0) is displayed. - Press the Up (▲) key once.
3		- The output current at the time of fault is displayed. - Press the Up (▲) key once.
4		- Operating status is displayed. A fault occurred during acceleration. - Press the STOP/RST key once.
5		- A fault condition is cleared and “nOn” is displayed.

When more than one fault occurs at the same time

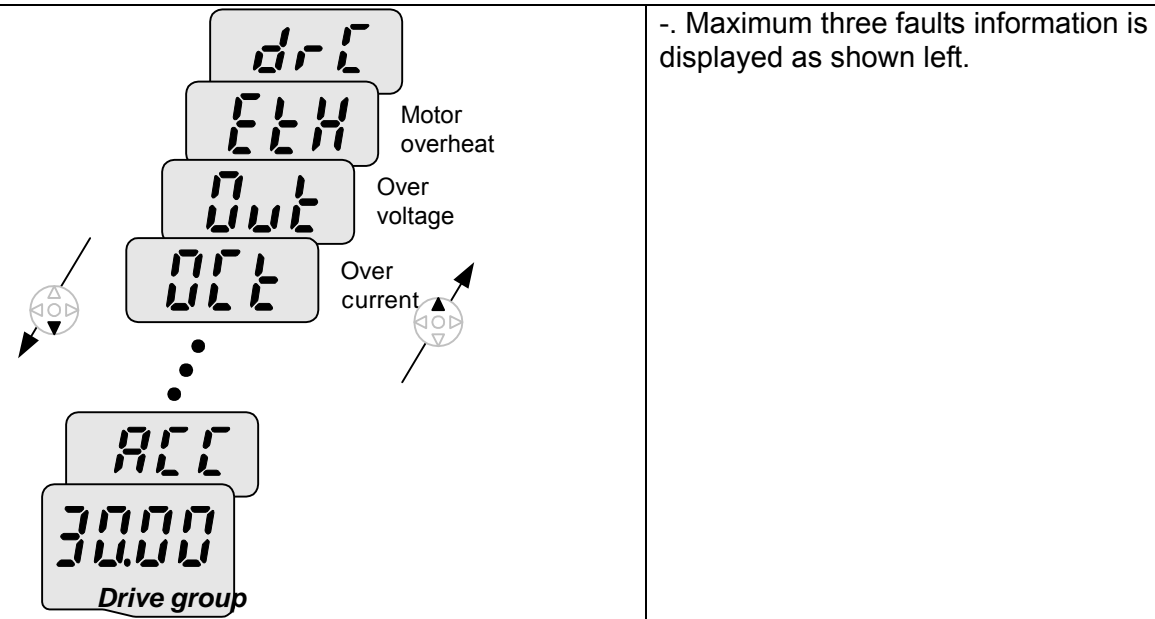

● Parameter initialize

How to initialize parameters of all four groups in H93

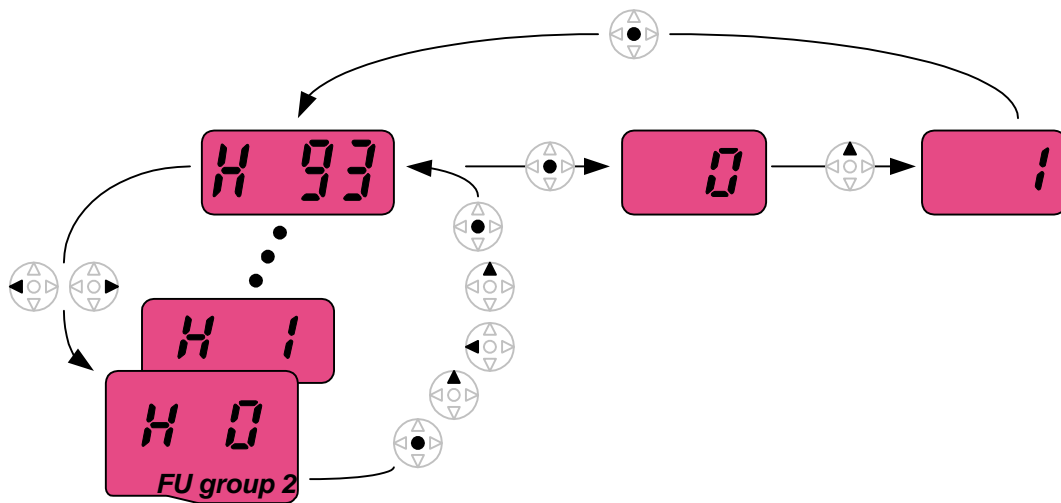



1		- In H0, press the Enter (●) key once.
2		- Code number of H0 is displayed. - Increase the value to 3 by pressing the Up (▲) key.
3		- In 3, press the Left (◀) key once to move the cursor to the left.
4		- 03 is displayed. 0 in 03 is active. - Increase the value to 9 by pressing the Up (▲) key.
5		- 93 is set. - Press the Enter (●) key once.
6		- The parameter number is displayed. - Press the Enter (●) key once.
7		- Present setting is 0. - Press the Up (▲) key once to set to 1 to activate parameter initialize.
8		- Press the Enter (●) key once.
9		- Return to the parameter number after blinking. Parameter initialize has been complete. - Press the either Left (◀) or Right (▶) key.
10		- Return to H0.

CHAPTER 6 - BASIC OPERATION

6.1 Frequency Setting and Basic Operation

Caution : The following instructions are given based on the fact that all parameters are set to factory defaults. Results could be different if parameter values are changed. In this case, initialize parameter values (see page 10-21) back to factory defaults and follow the instructions below.

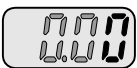
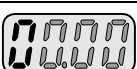
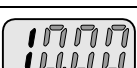
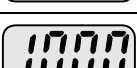
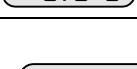
● Frequency Setting via keypad & operating via terminals

1		- Apply AC input power to the inverter.
2		- When 0.00 appears, press the Ent (●) key once.
3		- The second digit in 0.00 is lit as shown left. - Press the Left (◀) key three times.
4		- 00.00 is displayed and the first 0 is lit. - Press the Up (▲) key.
5		- 10.00 is set. Press the Ent (●) key once. - 10.00 is blinking. Press the Ent (●) key once.
6		- Run frequency is set to 10.00 Hz when the blinking stops. - Turn on the switch between P1 (FX) and CM terminals.
7		- RUN lamp begins to blink with FWD (Forward Run) lit and accelerating frequency is displayed on the LED. - When target run frequency 10Hz is reached, 10.00 is displayed. - Turn off the switch between P1 (FX) and CM terminals.
8		- RUN lamp begins to blink and decelerating frequency is displayed on the LED. - When run frequency is reached to 0Hz, Run and FWD lamp turn off and 10.00 is displayed.

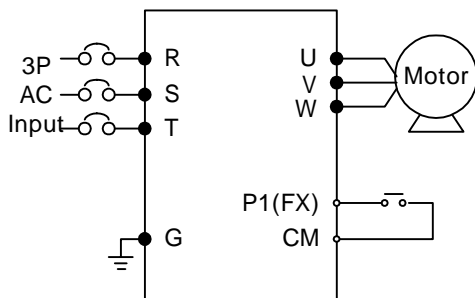



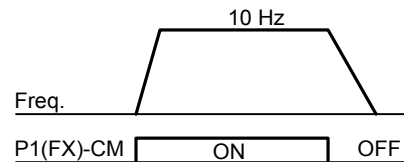

Wiring

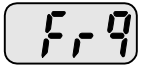

Operating pattern

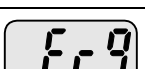
● Frequency Setting via potentiometer & operating via terminals

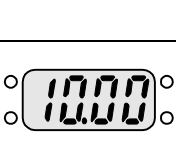

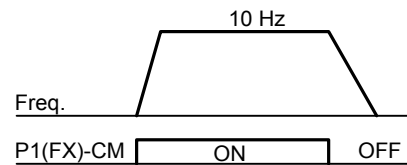
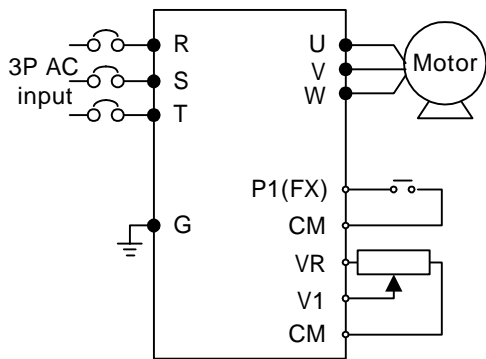







1		- Apply AC input power to the inverter.
2		- When 0.00 appears Press the Up (▲) key four times.
3		- Frq is displayed. Frequency setting mode is selectable. - Press the Ent (●) key once.
4		- Present setting method is set to 0 (frequency setting via keypad). - Press the Up (▲) key three times.
5		- After 3 (Frequency setting via potentiometer) is set, press the Ent (●) key once.
6		- Frq is redisplayed after 3 stops blinking. - Turn the potentiometer to set to 10.00 Hz in either Max or Min direction.
7		- Turn on the switch between P1 (FX) and CM (See Wiring below). - RUN lamp begins to blink with FWD lamp lit and the accelerating frequency is displayed on the LED. - When run frequency 10Hz is reached, the value is displayed as shown left. - Turn off the switch between P1 (FX) and CM terminals.
8		- RUN lamp begins to blink and decelerating frequency is displayed on the LED. - When run frequency is reached to 0Hz, Run and FWD lamp turn off and 10.00 is displayed.

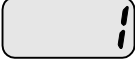

Wiring

Operating pattern

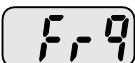
● Frequency setting via potentiometer & operating via the Run key

1		- . Apply AC input power to the inverter.
2		- . When 0.00 is displayed, press the Up (▲) key three times.
3		- . “drv” is displayed. Operating method is selectable. - . Press the Ent (●) key.
4		- . Check the present operating method (“1”: Run via control terminal). - . Press the Ent (●) key and then Down (▼) key once.
5		- . After setting “0”, press the Ent (●) key. When 0 is blinking, press the Ent again.
6		- . “drv” is displayed after “0” is blinking. Operation method is set via the Run key on the keypad. - . Press the Up (▲) key once.
7		- . Different frequency setting method is selectable. - . Press the Ent (●) key.
8		- . Check the present frequency setting method (“0” is run via keypad). - . Press the Up (▲) key three times.
9		- . After checking “3” (frequency setting via potentiometer), press the Ent (●) key.
10		- . “Frq” is displayed after “3” is blinking. Frequency setting is set via the potentiometer on the keypad. - . Turn the potentiometer to set to 10.0 Hz in either Max or Min direction.
11		- . Press the Run key on the keypad. - . RUN lamp begins to blink with FWD lamp lit and accelerating frequency is displayed on the LED. - . When run frequency 10Hz is reached, 10.00 is displayed as shown left. - . Press the STOP/RST key.
12		- . RUN lamp begins to blink and decelerating frequency is displayed on the LED. - . When run frequency is reached to 0Hz, Run and FWD lamp turn off and 10.00 is displayed.

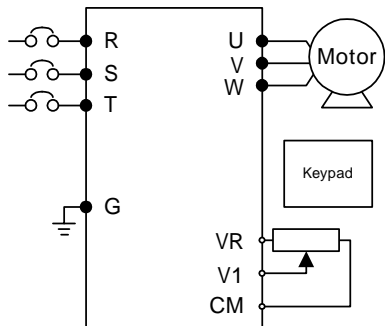

Wiring

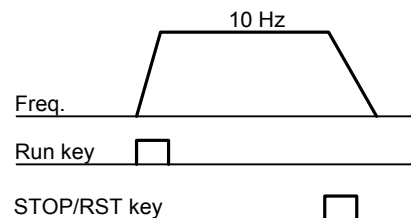

Operating pattern

Notes:

CHAPTER 7 - FUNCTION LIST

- Drive Group

LED display	Parameter name	Min/Max range	Description		Factory defaults	Adj. during run	Page	
0.00	[Frequency command]	0 ~ 400 [Hz]	This parameter sets the frequency that the inverter is commanded to output. During Stop: Frequency Command During Run: Output Frequency During Multi-step operation: <u>Multi-step frequency 0</u> . It cannot be set greater than F21-[Max frequency].		0.00	O	9-1	
ACC	[Accel time]	0 ~ 6000 [Sec]	During Multi-Accel/Decel operation, this parameter serves as Accel/Decel time 0.		5.0	O	9-12	
dEC	[Decel time]				10.0	O	9-12	
drv	[Drive mode]	0 ~ 3	0	Run/Stop via Run/Stop key on the keypad	1	X	9-8	
			1	Terminal operation FX: Motor forward run RX: Motor reverse run			9-8	
			2	FX: Run/Stop enable RX: Reverse rotation select				
			3	RS485 communication			9-9	
Frq	[Frequency setting method]	0 ~ 7	0	Digital	0	X	9-1	
			1				Keypad setting 2	9-1
			2	Analog			V1 1: -10 ~ +10 [V]	9-2
			3				V1 2: 0 ~ +10 [V]	9-4
			4				Terminal I: 0 ~ 20 [mA]	9-4
			5				Terminal V1 setting 1 + Terminal I	9-5
			6				Terminal V1 setting 2+ Terminal I	9-6
			7				RS485	9-6
St1	[Multi-Step frequency 1]	0 ~ 400 [Hz]	Sets Multi-Step frequency 1 during Multi-step operation.		10.00	O	9-7	
St2	[Multi-Step frequency 2]		Sets Multi-Step frequency 2 during Multi-step operation.		20.00	O	9-7	
St3	[Multi-Step frequency 3]		Sets Multi-Step frequency 3 during Multi-step operation.		30.00	O	9-7	
CUr	[Output current]		Displays the output current to the motor.		-	-	11-1	

● Drive Group

LED display	Parameter name	Min/Max range	Description	Factory defaults	Adj. during run	Page	
rPM	[Motor RPM]		Displays the number of Motor RPM.	-	-	11-1	
dCL	[Inverter DC link voltage]		Displays DC link voltage inside the inverter.	-	-	11-1	
vOL	[User display select]		This parameter displays the item selected at H73- [Monitoring item select].	vOL	-	11-2	
			vOL				Output voltage
			POr				Output power
			tOr				Torque
nOn	[Fault Display]		Displays the types of faults, frequency and operating status at the time of the fault	-	-	11-4	
drC	[Direction of motor rotation select]	F, r	Sets the direction of motor rotation when drv - [Drive mode] is set to either 0 or 1.	F	O	9-8	
			F				Forward
			r				Reverse

● Function group 1

LED display	Parameter name	Min/Max range	Description		Factory defaults	Adj. during run	Page
F 0	[Jump code]	0 ~ 60	Sets the parameter code number to jump.		1	O	5-5
F 1	[Forward/Reverse run disable]	0 ~ 2	0	Fwd and rev run enable	0	X	9-10
			1	Forward run disable			
			2	Reverse run disable			
F 2	[Accel pattern]	0 ~ 1	0	Linear	0	X	9-15
F 3	[Decel pattern]		1	S-curve			
F 4	[Stop mode select]	0 ~ 2	0	Decelerate to stop	0	X	9-20
			1	DC brake to stop			9-20
			2	Free run to stop			9-20
F 8 ¹⁾	[DC Brake start frequency]	0 ~ 60 [Hz]	This parameter sets DC brake start frequency. It cannot be set below F23 - [Start frequency].		5.00	X	10-1
F 9	[DC Brake wait time]	0 ~ 60 [sec]	When DC brake frequency is reached, the inverter holds the output for the setting time before starting DC brake.		0.1	X	10-1
F10	[DC Brake voltage]	0 ~ 200 [%]	This parameter sets the amount of DC voltage applied to a motor. It is set in percent of H33 – [Motor rated current].		50	X	10-1
F11	[DC Brake time]	0 ~ 60 [sec]	This parameter sets the time taken to apply DC current to a motor while motor is at a stop.		1.0	X	10-1
F12	[DC Brake start voltage]	0 ~ 200 [%]	This parameter sets the amount of DC voltage before a motor starts to run. It is set in percent of H33 – [Motor rated current].		50	X	10-2
F13	[DC Brake start time]	0 ~ 60 [sec]	DC voltage is applied to the motor for DC Brake start time before motor accelerates.		0	X	10-2
F14	[Time for magnetizing a motor]	0 ~ 60 [sec]	This parameter applies the current to a motor for the set time before motor accelerates during Sensorless vector control.		1.0	X	10-11
F20	[Jog frequency]	0 ~ 400 [Hz]	This parameter sets the frequency for Jog operation. It cannot be set above F21 – [Max frequency].		10.00	O	10-3

 Only displayed when F 4 is set to 1 (DC brake to stop).

● Function group 1

LED display	Parameter name	Min/Max range	Description	Factory defaults	Adj. during run	Page
F21 ¹⁾	[Max frequency]	40 ~ 400 [Hz]	This parameter sets the highest frequency the inverter can output. It is frequency reference for Accel/Decel (See H70) Caution: Any frequency cannot be set above Max frequency except Base frequency.	60.00	X	9-21
F22	[Base frequency]	30 ~ 400 [Hz]	The inverter outputs its rated voltage to the motor at this frequency (see motor nameplate).	60.00	X	9-17
F23	[Start frequency]	0 ~ 10 [Hz]	The inverter starts to output its voltage at this frequency. It is the frequency low limit.	0.50	X	9-21
F24	[Frequency high/low limit select]	0 ~ 1	This parameter sets high and low limit of run frequency.	0	X	9-21
F25 ²⁾	[Frequency high limit]	0 ~ 400 [Hz]	This parameter sets high limit of the run frequency. It cannot be set above F21 – [Max frequency].	60.00	X	
F26	[Frequency low limit]	0 ~ 400 [Hz]	This parameter sets low limit of the run frequency. It cannot be set above F25 - [Frequency high limit] and below F23 – [Start frequency].	0.50	X	
F27	[Torque Boost select]	0 ~ 1	0 Manual torque boost 1 Auto torque boost	0	X	9-19
F28	[Torque boost in forward direction]	0 ~ 15 [%]	This parameter sets the amount of torque boost applied to a motor during forward run. It is set in percent of Max output voltage.	5	X	9-19
F29	[Torque boost in reverse direction]		This parameter sets the amount of torque boost applied to a motor during reverse run. It is set as a percent of Max output voltage	5	X	9-19

¹⁾: If H40 is set to 3 (Sensorless vector), Max. frequency is settable up to 300Hz.

²⁾: Only displayed when F24 (Frequency high/low limit select) is set to 1.

● Function group 1

LED display	Parameter name	Min/Max range	Description		Factory defaults	Adj. during run	Page
F30	[V/F pattern]	0 ~ 2	0	{Linear}	0	X	9-17
			1	{Square}			9-17
			2	{User V/F}			9-18
F31 ¹⁾	[User V/F frequency 1]	0 ~ 400 [Hz]	It cannot be set above F21 – [Max frequency]. The value of voltage is set in percent of H70 – [Motor rated voltage]. The values of the lower-numbered parameters cannot be set above those of higher-numbered.		15.00	X	9-18
F32	[User V/F voltage 1]	0 ~ 100 [%]			25	X	
F33	[User V/F frequency 2]	0 ~ 400 [Hz]			30.00	X	
F34	[User V/F voltage 2]	0 ~ 100 [%]			50	X	
F35	[User V/F frequency 3]	0 ~ 400 [Hz]			45.00	X	
F36	[User V/F voltage 3]	0 ~ 100 [%]			75	X	
F37	[User V/F frequency 4]	0 ~ 400 [Hz]			60.00	X	
F38	[User V/F voltage 4]	0 ~ 100 [%]			100	X	
F39	[Output voltage adjustment]	40 ~ 110 [%]	This parameter adjusts the amount of output voltage. The set value is the percentage of input voltage.		100	X	9-18
F40	[Energy-saving level]	0 ~ 30 [%]	This parameter decreases output voltage according to load status.		0	0	10-12
F50	[Electronic thermal select]	0 ~ 1	This parameter is activated when the motor is overheated (time-inverse).		0	0	12-1

¹⁾: Set F30 to 2(User V/F) to display this parameter.

● Function group 1

LED display	Parameter name	Min/Max range	Description		Factory defaults	Adj. during run	Page
F51 ¹⁾	[Electronic thermal level for 1 minute]	50 ~ 200 [%]	This parameter sets max current capable of flowing to the motor continuously for 1 minute. The set value is the percentage of H33 – [Motor rated current]. It cannot be set below F52 – [Electronic thermal level for continuous].		150	0	12-1
	[Electronic thermal level for continuous]		This parameter sets the amount of current to keep the motor running continuously. It cannot be set higher than F51 – [Electronic thermal level for 1 minute].				
F53	[Motor cooling method]	0 ~ 1	0	Standard motor having cooling fan directly connected to the shaft	0	0	
			1	A motor using a separate motor to power a cooling fan.			
F54	[Overload warning level]	30 ~ 150 [%]	This parameter sets the amount of current to issue an alarm signal at a relay or multi-function output terminal (see I54, I55). The set value is the percentage of H33- [Motor rated current].		150	0	12-2
F55	[Overload warning time]	0 ~ 30 [Sec]	This parameter issues an alarm signal when the current greater than F54- [Overload warning level] flows to the motor for F55- [Overload warning time].		10	0	
F56	[Overload trip select]	0 ~ 1	This parameter turns off the inverter output when motor is overloaded.		1	0	12-3
F57	[Overload trip level]	30 ~ 200 [%]	This parameter sets the amount of overload current. The value is the percentage of H33- [Motor rated current].		180	0	
F58	[Overload trip time]	0 ~ 60 [Sec]	This parameter turns off the inverter output when the F57- [Overload trip level] of current flows to the motor for F58- [Overload trip time].		60	0	

: Set F50 to 1 to display this parameter.

● Function group 1

LED display	Parameter name	Min/Max range	Description			Factory defaults	Adj. during run	Page	
F59	[Stall prevention select]	0 ~ 7	This parameter stops accelerating during acceleration, decelerating during constant speed run and stops decelerating during deceleration.			0	X	12-3	
				During Decel	During constant run				During Accel
				Bit 2	Bit 1				Bit 0
			0	-	-				-
			1	-	-				✓
			2	-	✓				-
			3	-	✓				✓
			4	✓	-				-
			5	✓	-				✓
			6	✓	✓				-
7	✓	✓	✓						
F60	[Stall prevention level]	30 ~ 150 [%]	This parameter sets the amount of current to activate stall prevention function during Accel, Constant or Decel run. The set value is the percentage of the H33- [Motor rated current].			150	X	12-3	

● Function group 2

LED display	Parameter name	Min/Max range	Description	Factory defaults	Adj. during run	Page
H 0	[Jump code]	0~95	Sets the code number to jump.	1	O	5-5
H 1	[Fault history 1]	-	Stores information on the types of faults, the frequency, the current and the Accel/Decel condition at the time of fault. The latest fault is automatically stored in the H 1- [Fault history 1].	nOn	-	11-4
H 2	[Fault history 2]	-		nOn	-	
H 3	[Fault history 3]	-		nOn	-	
H 4	[Fault history 4]	-		nOn	-	
H 5	[Fault history 5]	-		nOn	-	
H 6	[Reset fault history]	0~1	Clears the fault history saved in H 1-5.	0	O	
H 7	[Dwell frequency]	0~400 [Hz]	When run frequency is issued, motor starts to accelerate after dwell frequency is applied to the motor during H8- [Dwell time]. [Dwell frequency] can be set within the range of F21- [Max frequency] and F23- [Start frequency].	5.00	X	10-5
H 8	[Dwell time]	0~10 [sec]	Sets the time for dwell operation.	0.0	X	
H10	[Skip frequency select]	0 ~ 1	Sets the frequency range to skip to prevent undesirable resonance and vibration on the structure of the machine.	0	X	9-22
H11 ¹⁾	[Skip frequency low limit 1]	0~400 [Hz]	Run frequency cannot be set within the range of H11 thru H16. The frequency values of the low numbered parameters cannot be set above those of the high numbered ones. Settable within the range of F21 and F23.	10.00	X	
H12	[Skip frequency high limit 1]			15.00	X	
H13	[Skip frequency low limit 2]			20.00	X	
H14	[Skip frequency high limit 2]			25.00	X	
H15	[Skip frequency low limit 3]			30.00	X	
H16	[Skip frequency high limit 3]			35.00	X	
H17	[S-Curve accel/decel start side]	1~100 [%]	Set the speed reference value to form a curve at the start during accel/decel. If it is set higher, linear zone gets smaller.	40	X	9-15
H18	[S-Curve accel/decel end side]	1~100 [%]	Set the speed reference value to form a curve at the end during accel/decel. If it is set higher, linear zone gets smaller.	40	X	

1: only displayed when H10 is set to 1. # H17, H18 are used when F2, F3 are set to 1 (S-curve).

● Function group 2

LED display	Parameter name	Min/Max range	Description				Factory defaults	Adj. during run	Page	
H19	[Input/output phase loss protection select]	0 ~ 3	0	Disabled	1	Output phase protection	0	O	12-5	
			2	Input phase protection	3	Input/output phase protection				
H20	[Power On Start select]	0 ~ 1	This parameter is activated when drv is set to 1 or 2 (Run/Stop via Control terminal). Motor starts acceleration after AC power is applied while FX or RX terminal is ON.				0	O	9-11	
H21	[Restart after fault reset selection]	0 ~ 1	This parameter is activated when drv is set to 1 or 2 (Run/Stop via Control terminal). Motor accelerates after the fault condition is reset while the FX or RX terminal is ON.				0	O	9-11	
H22 ¹⁾	[Speed Search Select]	0 ~ 15	This parameter is active to prevent any possible fault when the inverter outputs its voltage to the running motor.				0	O	10-13	
				1. H20-[Power On start]	2. Restart after instant power failure	3. Operation after fault				4. Normal accel
				Bit 3	Bit 2	Bit 1				Bit 0
			0	-	-	-				-
			1	-	-	-				✓
			2	-	-	✓				
			3	-	-	✓				✓
4	-	✓	-	-						

1 Normal acceleration has first priority. Even though #4 is selected along with other bits, Inverter performs Speed search #4.

● Function group 2

LED display	Parameter name	Min/Max range	Description					Factory defaults	Adj. during run	Page
H22 1)				1. H20- [Power On start]	2. Resta rt after instant power failure	3. Operati on after fault	4. Normal accel			10-13
				Bit 3	Bit 2	Bit 1	Bit 0			
			5	-	✓	-	✓			
			6	-	✓	✓	-			
			7	-	✓	✓	✓			
			8	✓	-	-	-			
			9	✓	-	-	✓			
			10	✓	-	✓	-			
			11	✓	-	✓	✓			
			12	✓	✓	-	-			
			13	✓	✓	-	✓			
			14	✓	✓	✓	-			
15	✓	✓	✓	✓						
H23	[Current level during Speed search]	80~200 [%]	This parameter limits the amount of current during speed search. The set value is the percentage of the H33- [Motor rated current].					100	O	10-13
H24	[P gain during Speed search]	0~9999	It is the Proportional gain used for Speed Search PI controller.					100	O	
H25	[I gain during speed search]	0~9999	It is the Integral gain used for Speed search PI controller.					1000	O	
H26	[Number of Auto Restart try]	0 ~10	This parameter sets the number of restart tries after a fault occurs. Auto Restart is deactivated if the fault outnumbers the restart tries. This function is active when [drv] is set to 1 or 2 {Run/Stop via control terminal}. Deactivated during active protection function (OHT, LVT, EXT, HWT etc.).					0	O	

● Function group 2

LED display	Parameter name	Min/Max range	Description		Factory defaults	Adj. during run	Page
H27	[Auto Restart time]	0~60 [sec]	This parameter sets the time between restart tries.		1.0	O	10-15
H30	[Motor type select]	0.2~ 7.5	0.2	0.2kW	7.5 ¹⁾	X	10-6
			~	~			
			5.5	5.5kW			
			7.5	7.5kW			
H31	[Number of motor poles]	2 ~ 12	This setting is displayed via rPM in drive group.		4	X	
H32	[Rated slip frequency]	0 ~ 10 [Hz]	$f_s = f_r - \left(\frac{rpm \times P}{120} \right)$ Where, f_s = Rated slip frequency f_r = Rated frequency rpm = Motor nameplate RPM P = Number of Motor poles		2.33 ²⁾	X	
H33	[Motor rated current]	1.0~50 [A]	Enter motor rated current on the nameplate.		26.3	X	
H34	[No Load Motor Current]	0.1~ 20 [A]	Enter the current value detected when the motor is rotating in rated rpm after the load connected to the motor shaft is removed. Enter the 50% of the rated current value when it is difficult to measure H34 - [No Load Motor Current].		11	X	10-6
H36	[Motor efficiency]	50~100 [%]	Enter the motor efficiency (see motor nameplate).		87	X	
H37	[Load inertia rate]	0 ~ 2	Select one of the following according to motor inertia.		0	X	10-1
			0	Less than 10 times			
			1	About 10 times			
			2	More than 10 times			

¹⁾: H30 is preset based on inverter rating.

²⁾: H32 ~ H36 factory default values are set based on LG motor.

LED display	Parameter name	Min/Max range	Description	Factory defaults	Adj. during run	Page	
H39	[Carrier frequency select]	1 ~ 15 [kHz]	This parameter affects the audible sound of the motor, noise emission from the inverter, inverter temp, and leakage current. If the set value is higher, the inverter sound is quieter but the noise from the inverter and leakage current will become greater.	3	O	10-16	
H40	[Control mode select]	0 ~ 3	0	{Volts/frequency Control}	0	X	9-17
			1	{Slip compensation control}			10-6
			2	{PID Feedback control}			10-8
			3	{Sensorless vector control}			10-11
H41	[Auto tuning]	0 ~ 1	If this parameter is set to 1, it automatically measures parameters of the H42 and H43.	0	X	10-10	
H42	[Stator resistance (Rs)]	0 ~ 14 [Ω]	This is the value of the motor stator resistance.	-	X		
H44	[Leakage inductance (L σ)]	0~ 300.0 [mH]	This is leakage inductance of the stator and rotor of the motor.	-	X		
H45 ¹⁾	[Sensorless P gain]	0~ 32767	P gain for Sensorless control	1000	O		
H46	[Sensorless I gain]		I gain for Sensorless control	100	O		
H50 ²⁾	[PID Feedback select]	0 ~ 1	0	Terminal I input (0 ~ 20 mA)	0	X	10-8
			1	Terminal V1 input (0 ~ 10 V)			
H51	[P gain for PID controller]	0~ 999.9 [%]	This parameter sets the gains for the PID controller.	300.0	O		
H52	[Integral time for PID controller (I gain)]	0.1~32.0 [sec]		1.0	O		
H53	[Differential time for PID controller (D gain)]	0 ~ 30.0 [sec]		0.0	O		
H54	[F gain for PID controller]	0~ 999.9 [%]	This is the Feed forward gain for the PID controller.	0.0	O		

¹⁾: Set H40 to 3 (Sensorless vector control) to display this parameter.

²⁾: Set H40 to 2 (PID control) to display this parameter.

LED display	Parameter name	Min/Max range	Description		Factory defaults	Adj. during run	Page
H55	[PID output frequency limit]	0 ~ 400 [Hz]	This parameter limits the amount of the output frequency thru the PID control. The value is settable within the range of F21 – [Max frequency] and H23 – [Start frequency].		60.00	O	10-8
H70	[Frequency Reference for Accel/Decel]	0 ~ 1	0	Based on Max freq (F21)	0	X	9-12
			1	Based on Delta freq.			
H71	[Accel/Decel time scale]	0 ~ 2	0	Settable unit: 0.01 second.	1	O	9-13
			1	Settable unit: 0.1 second.			
			2	Settable unit: 1 second.			
H72	[Power on display]	0 ~ 13	This parameter selects the parameter to be displayed on the keypad when the input power is first applied.		0	O	11-2
			0	Frequency command			
			1	Accel time			
			2	Decel time			
			3	Drive mode			
			4	Frequency mode			
			5	Multi-Step frequency 1			
			6	Multi-Step frequency 2			
			7	Multi-Step frequency 3			
			8	Output current			
			9	Motor rpm			
			10	Inverter DC link voltage			
			11	User display select (H73)			
			12	Fault display			
13	Direction of motor rotation select						
H73	[Monitoring item select]	0 ~ 2	One of the following can be monitored via vOL - [User display select].		0	O	11-2
			0	Output voltage [V]			
			1	Output power [kW]			
			2	Torque [kgf · m]			

LED display	Parameter name	Min/Max range	Description		Factory defaults	Adj. during run	Page
H74	[Gain for Motor rpm display]	1 ~ 1000 [%]	This parameter is used to change the motor speed display to rotating speed (r/min) or mechanical speed (m/mi).		100	O	11-1
H75	[DB resistor operating rate limit select]	0 ~ 1	0	Unlimited	1	O	12-9
			1	Use DB resistor for the H76 set time.			
H76	[DB resistor operating rate]	0 ~ 30[%]	Set the percent of DB resistor operating rate to be activated during one sequence of operation.		10	O	
H77	[Cooling fan control]	0 ~ 1	0	Always ON	0	O	10-18
			1	Keeps ON when its temp is higher than inverter protection limit temp. Activated only during operation when its temp is below that of inverter protection limit.			
H78	[Operating method select when cooling fan malfunctions]	0 ~ 1	0	Continuous operation when cooling fan malfunctions.	0	O	10-19
			1	Operation stopped when cooling fan malfunctions.			
H79	[S/W version]	0 ~ 10.0	This parameter displays the inverter software version.		1.0	X	-
H81	[2 nd motor Accel time]	0 ~ 6000 [sec]	This parameter is active when the selected terminal is ON after I17-I24 is set to 12 {2 nd motor select}.		5.0	O	10-16
H82	[2 nd motor Decel time]				10.0	O	
H83	[2 nd motor base frequency]	30 ~ 400 [Hz]			60.00	X	
H84	[2 nd motor V/F pattern]	0 ~ 2			0	X	
H85	[2 nd motor forward torque boost]	0 ~ 15 [%]			5	X	
H86	[2 nd motor reverse torque boost]		5	X			

LED display	Parameter name	Min/Max range	Description	Factory defaults	Adj. during run	Page	
H87	[2 nd motor stall prevention level]	30~150 [%]		150	X	10-16	
H88	[2 nd motor Electronic thermal level for 1 min]	50~200 [%]		150	O		
H89	[2 nd motor Electronic thermal level for continuous]			100	O		
H90	[2 nd motor rated current]	0.1~50 [A]		26.3	X		
H91	[Parameter read]	0 ~ 1	Copy the parameters from inverter and save them into keypad.	0	X	10-20	
H92	[Parameter write]	0 ~ 1	Copy the parameters from keypad and save them into inverter.	0	X		
H93	[Parameter initialize]	0 ~ 5	This parameter is used to initialize parameters back to the factory default value.	0	X	10-21	
			0				-
			1				All parameter groups are initialized to factory default value.
			2				Only Drive group is initialized.
			3				Only Function group 1 is initialized.
			4				Only Function group 2 is initialized.
5	Only I/O group is initialized.						
H94	[Password register]	0 ~ FFFF	Password for H95-[Parameter lock]. Set as Hexa value.	0	O	10-21	
H95	[Parameter lock]	0 ~ FFFF	This parameter is able to lock or unlock parameters by typing password registered in H94.	0	O	10-23	
			UL (Unlock)				Parameter change enable
			L (Lock)				Parameter change disable

● Input/output group

LED display	Parameter name	Min/Max range	Description	Factory defaults	Adj. during run	Page	
I 0	[Jump code]	0 ~ 63	This parameter sets the code number to jump	1	O	5-5	
I 1	[Filter time constant for NV input]	0 ~ 9999	Adjusts the responsiveness of V1 (-) input (-10V~0V).	10	O	9-2	
I 2	[NV input Min voltage]	0 ~ -10 [V]	Sets the minimum voltage of the NV (-10V~0V) input.	0.00	O		
I 3	[Frequency corresponding to I 2]	0 ~ 400 [Hz]	Sets the inverter output minimum frequency at minimum voltage of the NV input.	0.00	O		
I 4	[NV input Max voltage]	0 ~ -10 [V]	Set the maximum voltage of the NV input.	10.0	O		
I 5	[Frequency corresponding to I 4]	0 ~ 400 [Hz]	Set the inverter output maximum frequency at maximum voltage of the NV input.	60.00	O		
I 6	[Filter time constant for V1 input]	0 ~ 9999	Adjusts the responsiveness of V1 input (0 ~ +10V).	10	O		9-4
I 7	[V1 input Min voltage]	0 ~ 10 [V]	Sets the minimum voltage of the V1 input.	0	O		
I 8	[Frequency corresponding to I 7]	0 ~ 400 [Hz]	Sets the inverter output minimum frequency at minimum voltage of the V1 input.	0.00	O		
I 9	[V1 input max voltage]	0 ~ 10 [V]	Set the maximum voltage of the V1 input.	10	O		
I10	[Frequency corresponding to I 9]	0 ~ 400 [Hz]	Set the inverter output maximum frequency at maximum voltage of the V1 input.	60.00	O		
I11	[Filter time constant for I input]	0 ~ 9999	Set the input section's internal filter constant for I input.	10	O	9-4	
I12	[I input minimum current]	0 ~ 20 [mA]	Set the Minimum Current of I input.	4.00	O		
I13	[Frequency corresponding to I 12]	0 ~ 400 [Hz]	Set the inverter output minimum frequency at minimum current of I input.	0.00	O		
I14	[I input max current]	0 ~ 20 [mA]	Set the Maximum Current of I input.	20.00	O		
I15	[Frequency corresponding to I 14]	0 ~ 400 [Hz]	Set the inverter output maximum frequency at maximum current of I input.	60.00	O		9-4

● Input/output group

LED display	Parameter name	Min/Max range	Description		Factory defaults	Adj. during run	Page		
I16	[Criteria for Analog Input Signal loss]	0 ~ 2	0: Disabled 1: activated below half of set value. 2: activated below set value.		0	○	12-7		
I17	[Multi-function input terminal P1 define]	0 ~ 24	0	Forward run command	0	○	9-7		
			1	Reverse run command					
I18	[Multi-function input terminal P2 define]		2	Emergency Stop Trip	1	○	-		
			3	Reset when a fault occurs {RST}			-		
I19	[Multi-function input terminal P3 define]		4	Jog operation command	2	○	10-3		
			5	Multi-Step freq – Low			9-7		
I20	[Multi-function input terminal P4 define]		6	Multi-Step freq – Mid	3	○			
			7	Multi-Step freq – High					
I21	[Multi-function input terminal P5 define]		8	Multi Accel/Decel – Low	4	○	9-14		
			9	Multi Accel/Decel – Mid					
I22	[Multi-function input terminal P6 define]		10	Multi Accel/Decel – High	5	○			
			11	DC brake during stop				10-2	
I23	[Multi-function input terminal P7 define]		12	2nd motor select	6	○	10-16		
			13	-			-		
I24	[Multi-function input terminal P8 define]		14	-	7	○	-		
			15	Up-down			Frequency increase (UP) command	10-4	
			16				Frequency decrease command (DOWN)		
			17	3-wire operation					
			18	External trip: A Contact (EtA)			12-5		
			19	External trip: B Contact (EtB)					
			20	-			-		
			21	Exchange between PID operation and V/F operation			10-8		
			22	Exchange between option and Inverter			-		
			23	Analog Hold			9-6		
24	Accel/Decel Disable		9-16						

See “Chapter 14 Troubleshooting and maintenance” for External trip A/B contact.

● Input/output group

LED display	Parameter name	Min/Max range		Description						Factory default	Adj. during run	Page
		BIT 7	BIT 6	BIT 5	BIT 4	BIT 3	BIT 2	BIT 1	BIT 0			
I25	[Input terminal status display]	P8	P7	P6	P5	P4	P3	P2	P1	-	-	11-3
I26	[Output terminal status display]	BIT1			BIT0			-	-	11-3		
		3AC			MO							
I27	[Filtering time constant for Multi-function Input terminal]	2 ~ 50		If the value is set higher, the responsiveness of the Input terminal is getting slower.						15	O	-
I30	[Multi-Step frequency 4]	0 ~ 400 [Hz]		It cannot be set greater than F21 – [Max frequency].						30.00	O	9-7
I31	[Multi-Step frequency 5]									25.00	O	
I32	[Multi-Step frequency 6]									20.00	O	
I33	[Multi-Step frequency 7]									15.00	O	
I34	[Multi-Accel time 1]	0~ 6000 [sec]								3.0	O	9-14
I35	[Multi-Decel time 1]									3.0		
I36	[Multi-Accel time 2]									4.0		
I37	[Multi-Decel time 2]									4.0		
I38	[Multi-Accel time 3]									5.0		
I39	[Multi-Decel time 3]									5.0		
I40	[Multi-Accel time 4]									6.0		
I41	[Multi-Decel time 4]									6.0		
I42	[Multi-Accel time 5]									7.0		
I43	[Multi-Decel time 5]									7.0		
I44	[Multi-Accel time 6]									8.0		
I45	[Multi-Decel time 6]									8.0		
I46	[Multi-Accel time 7]									9.0		
I47	[Multi-Decel time 7]									9.0		
I50	[Analog output item select]	0 ~ 3		Output item	Output to 10[V]		-	O	11-5			
					200V	400V						

● Input/output group

LED display	Parameter name	Min/Max range	Description		Factory default	Adj. during run	Page	
			0	Output freq.	Max frequency			
			1	Output current	150 %			
			2	Output voltage	AC 282V	AC 564V		
			3	Inverter DC link voltage	DC 400V	DC 800V		
I51	[Analog output level adjustment]	10~200 [%]	Based on 10V.		100	O	11-5	
I52	[Frequency detection level]	0 ~ 400 [Hz]	Used when I54 or I55 is set to 0-4. Cannot be set higher than F21.		30.00	O	11-7	
I53	[Frequency detection bandwidth]				10.00	O		
I54	[Multi-function output terminal select]	0 ~ 18	0	FDT-1	12	O	11-7	
			1	FDT-2			11-7	
I55	[Fault relay output]		2	FDT-3	17		11-8	
			3	FDT-4			11-8	
			4	FDT-5			11-9	
			5	Overload (OL)			11-9	
			6	Inverter Overload (IOL)				
			7	Motor stall (STALL)				
			8	Overvoltage Trip (OV)				
			9	Low voltage trip (LV)				
			10	Inverter Overheat (OH)				
			11	Command loss				
			12	During Run				11-10
			13	During Stop				
			14	During constant run				
			15	During speed searching				
			16	Wait time for run signal input				
			17	Fault relay output select				
			18	Warning for cooling fan trip				

LED display	Parameter name	Min/Max range	Description			Factory defaults	Adj. during run	Page	
I56	[Fault relay output]	0 ~ 7		When setting the H26— [Number of auto restart try]	When the trip other than low voltage trip occurs	When the low voltage trip occurs	2	O	11-7
				Bit 2	Bit 1	Bit 0			
			0	-	-	-			
			1	-	-	✓			
			2	-	✓	-			
			3	-	✓	✓			
			4	✓	-	-			
			5	✓	-	✓			
			6	✓	✓	-			
7	✓	✓	✓						
I57	[Output terminal select when communication error occurs]	0 ~ 3		Multi-function relay	Multi-function output terminal	0	X	11-12	
				Bit 1	Bit 0				
			0	-	-				
			1	-	✓				
			2	✓	-				
3	✓	✓							
I59	[Communication protocol select]	0 ~ 1	Set communication protocol.			0	X	13-2	
			0	Modbus RTU					
			1	LG BUS					
I60	[Inverter number]	1 ~ 32	Set for RS485 communication			1	O	13-2	
I61	[Baud rate]	0 ~ 4	Select the Baud rate of the RS485.			3	O	13-2	
			0	1200 [bps]					
			1	2400 [bps]					
			2	4800 [bps]					
			3	9600 [bps]					
4	19200 [bps]								
I62	[Drive mode select after loss of frequency command]	0 ~ 2	It is used when freq command is given via V1 /I terminal or RS485.			0	O	12-7	
			0	Continuous operation at the frequency before its command is lost.					
			1	Free Run stop (Coast to stop)					
			2	Decel to stop					

LED display	Parameter name	Min/Max range	Description	Factory defaults	Adj. during run	Page
I63	[Wait time after loss of frequency command]	0.1 ~ 12 [sec]	This is the time inverter determines whether there is the input frequency command or not. If there is no frequency command input during this time, inverter starts operation via the mode selected at I62.	1.0	-	

Notes:

CHAPTER 8 - CONTROL BLOCK DIAGRAM

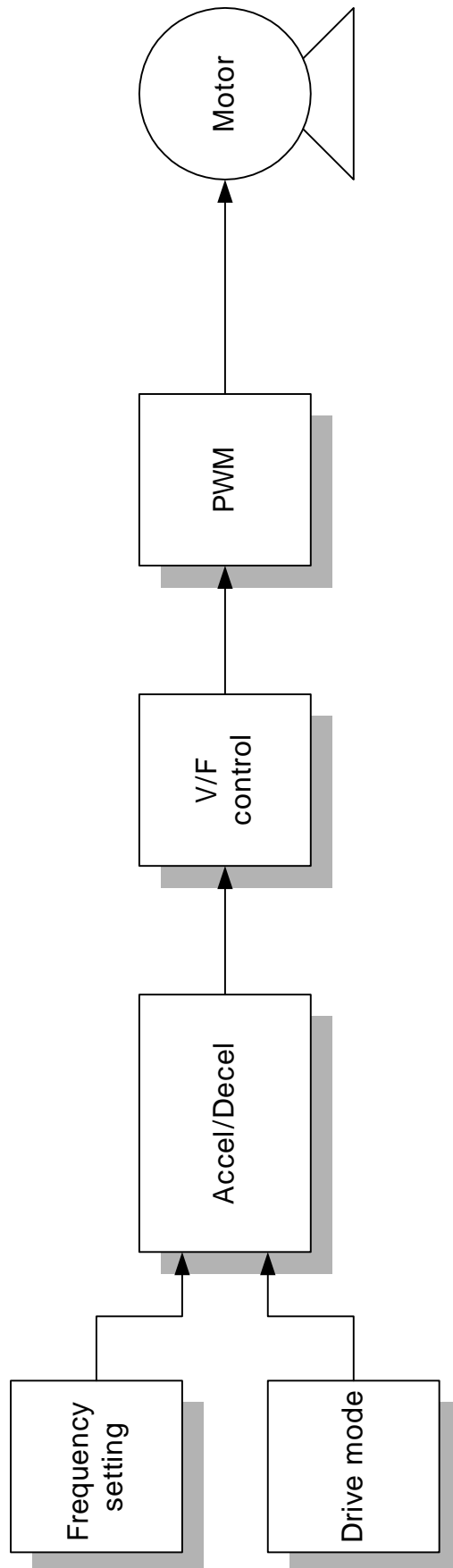

8.1 Frequency and Drive mode setting

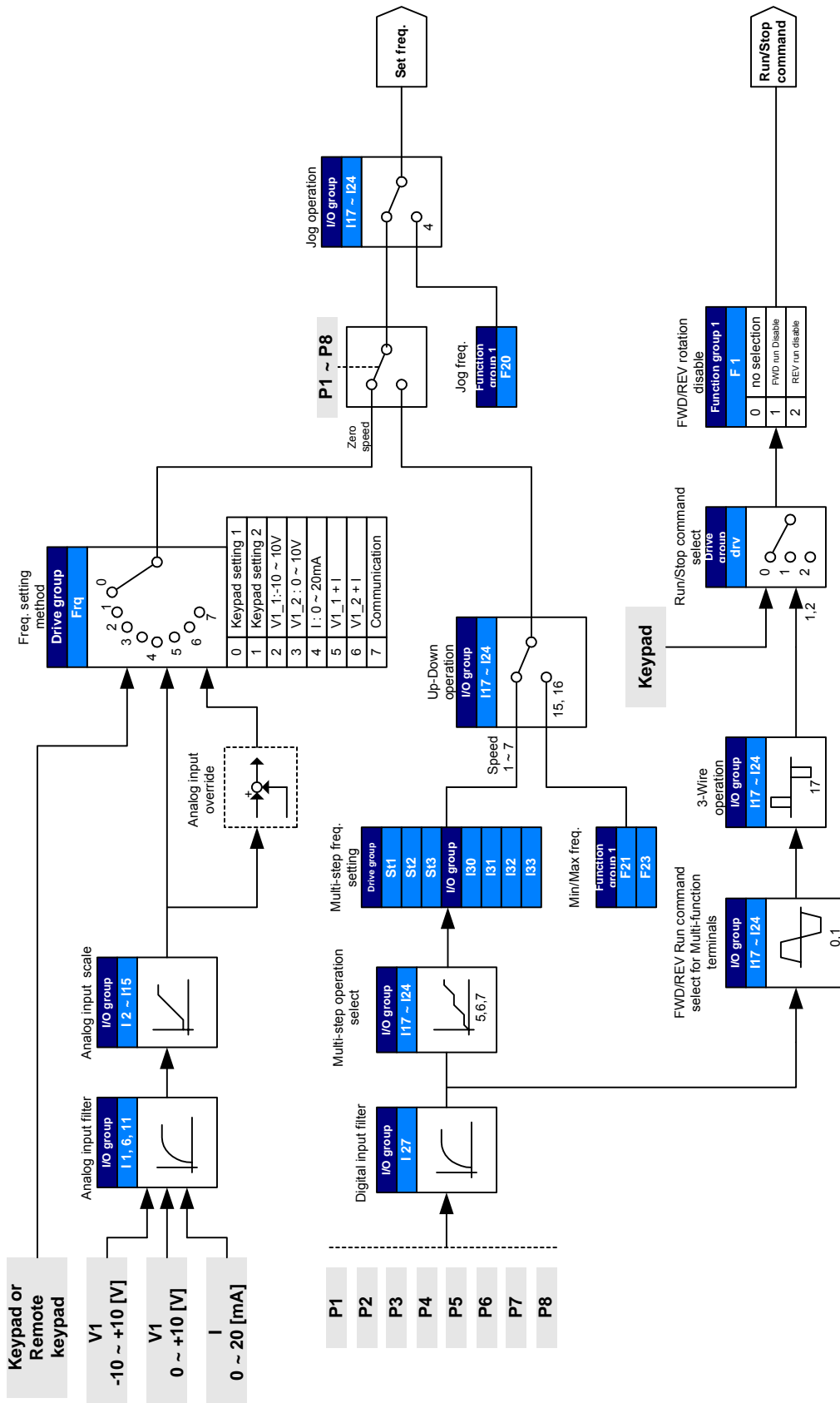

8.2 Accel/Decel setting and V/F control

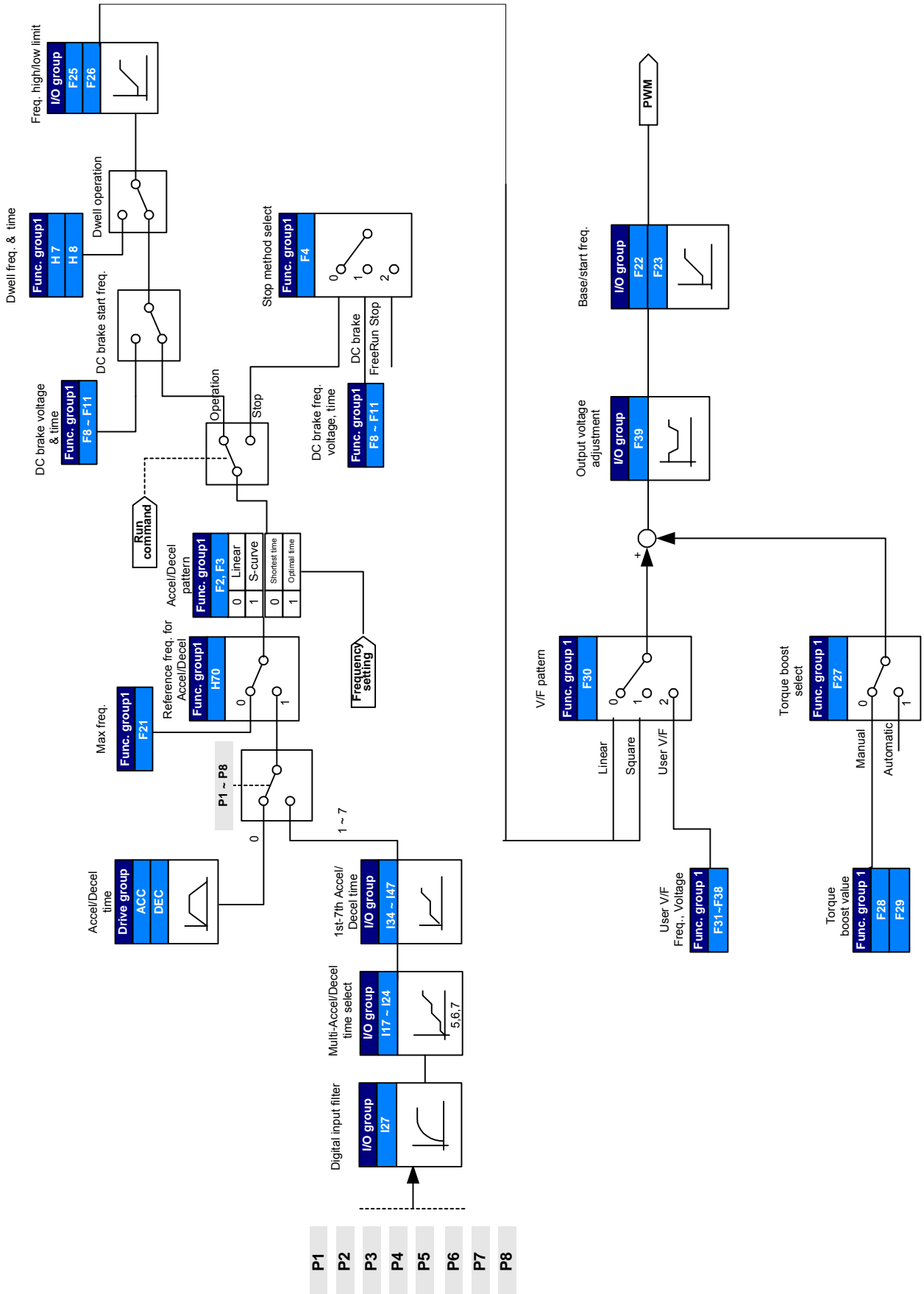

Notes:

CHAPTER 9 - BASIC FUNCTIONS

9.1 Frequency mode

- Keypad Frequency setting 1

Group	Code	Parameter Name	Setting	Range	Initial	Unit
Drive group	0.00	[Frequency Command]	-	0 ~ 400	0.00	Hz
	Frq	[Frequency mode]	0	0 ~ 7	0	

- Set **Frq** – [Frequency mode] to 0 {Frequency setting via Keypad 1}.
 - Set the desired frequency in **0.00** and press the Prog/Ent (●) key to enter the value into memory.
 - The value is settable less than **F21** – [Max frequency].
-

▶ When remote keypad is connected, keypad keys on the body are deactivated.

- Keypad Frequency setting 2

Group	Code	Parameter Name	Setting	Range	Initial	Unit
Drive group	0.00	[Frequency Command]	-	0 ~ 400	0.00	Hz
	Frq	[Frequency mode]	1	0 ~ 7	0	

- Set **Frq** – [Frequency mode] to 1{Frequency setting via Keypad 2}.
 - In **0.00**, frequency is changed upon pressing the Up (▲)/Down (▼) key. In this case, UP/Down keys serve as a potentiometer.
 - The value is settable less than **F21** – [Max frequency].
-

▶ When remote keypad is connected, keypad keys on the body are deactivated.

● Frequency setting via $-10[V] \sim +10[V]$ input

Group	Code	Parameter Name	Setting	Range	Initial	Unit
Drive group	0.00	[Frequency Command]	-	-	-	Hz
	Frq	[Frequency Mode]	2	0 ~ 7	0	
I/O group	I 1	[Filter time constant for NV input]	10	0 ~ 9999	10	
	I 2	[NV input minimum voltage]	-	0 ~ -10	0.0	V
	I 3	[Frequency corresponding to I2]	-	0 ~ 400	0.00	Hz
	I 4	[NV input max voltage]	-	0 ~ 10	10.00	V
	I 5	[Frequency corresponding to I4]	-	0 ~ 400	60.00	Hz
	I 6 ~ I 10	[V1 input]				

- Set **Frq** – [Frequency Mode] to 2.
- The set frequency can be monitored in **0.00** - [Frequency Command].

- ▶ Apply $-10V \sim +10V$ signal between V1 and CM terminal.

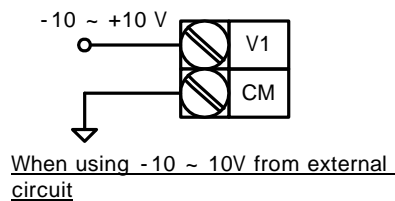

- ▶ Output frequency corresponding to $-10V \sim +10V$ input voltage to V1 terminal

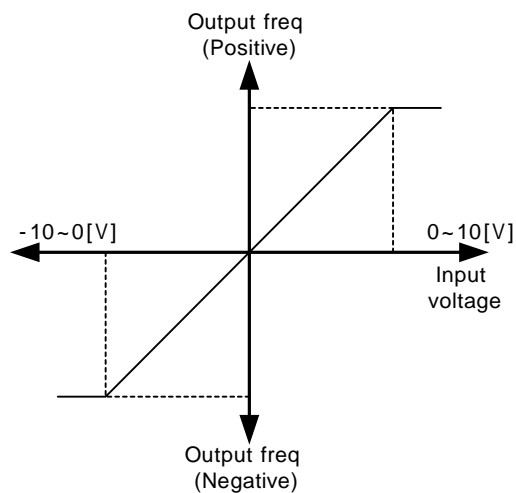

- ▶ I 1 (Filter time constant for NV input): Effective for eliminating noise in the frequency setting circuit. Increase the filter time constant if steady operation cannot be performed due to noise. A larger setting results in slower response (t gets longer).

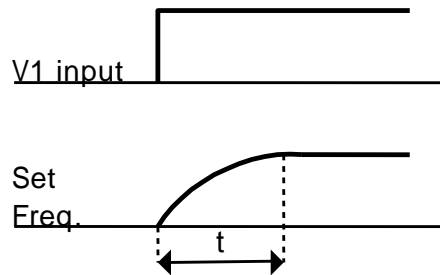

- ▶ I 2 ~ I 5: Setting input range and corresponding frequency to -10V ~ 0V V1 input voltage

Ex) when minimum (-) input voltage is -2V with corresponding frequency 10Hz and Max voltage is -8V with run freq. 50Hz.

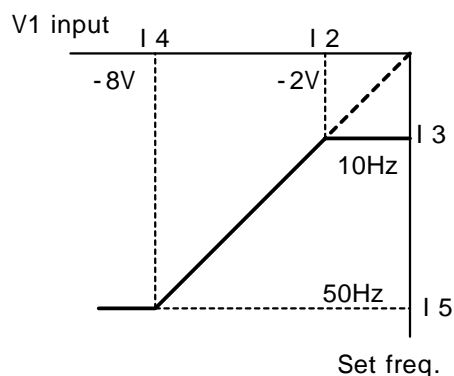

- ▶ I 6 ~ I10: Setting input range and corresponding frequency to 0 ~ +10V V0 input voltage

Ex) when minimum (+) input voltage is 2V with corresponding frequency 10Hz and Max voltage is 8V with run freq.

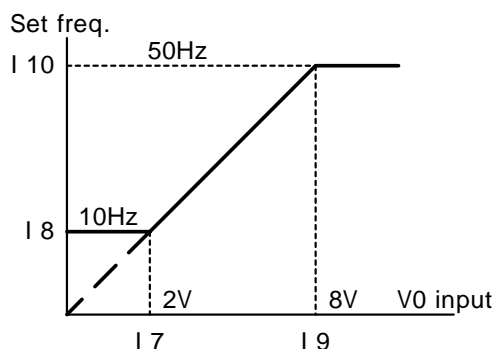

● Frequency setting via 0 ~ 10 [V] input or Terminal Potentiometer

Group	Code	Parameter Name	Setting	Range	Initial	Unit
Drive group	0.00	[Frequency Command]	-	-	-	Hz
	Frq	[Frequency Mode]	3	0 ~ 7	0	
I/O group	I 6	[Filter time constant for V1 input]	10	0 ~ 9999	10	
	I 7	[V1 input Min voltage]	-	0 ~ 10	0	V
	I 8	[Frequency corresponding to I 7]	-	0 ~ 400	0.00	Hz
	I 9	[V1 input max voltage]	-	0 ~ 10	10	V
	I10	[Frequency corresponding to I 9]	-	0 ~ 400	60.00	Hz

- Select 3 in Frq code of Drive group.
- 0-10V can be directly applied from an external controller or a potentiometer connected on terminals VR, V1 and CM.

▶ Wire the terminals as shown below and refer to page 9-3 for I 6 ~ I 10.

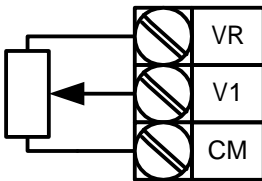

Wiring of potentiometer

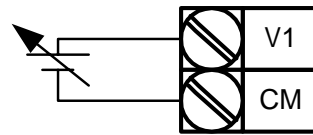

0 ~ 10V input via external controller

● Frequency setting via 0 ~ 20 [mA] input

Group	Code	Parameter Name	Setting	Range	Initial	Unit
Drive group	0.00	[Frequency Command]	-	-	-	Hz
	Frq	[Frequency Mode]	4	0 ~ 7	0	
I/O group	I11	[Filter time constant for I input]	10	0 ~ 9999	10	
	I12	[I input minimum current]	-	0 ~ 20	4	mA
	I13	[Frequency corresponding to I12]	-	0 ~ 400	0.00	Hz
	I14	[I input max current]	-	0 ~ 20	20	mA
	I15	[Frequency corresponding to I14]	-	0 ~ 400	60.00	Hz

- Select 4 in Frq code of Drive group.
- Frequency is set via 0~20mA input between I and CM terminal.

- Frequency setting via -10 ~ +10V voltage input + 0 ~ 20mA input

Group	Code	Parameter Name	Setting	Range	Initial	Unit
Drive group	0.00	[Frequency Command]	-	-	-	Hz
	Frq	[Frequency Mode]	5	0 ~ 7	0	

- Select 5 in Frq code of Drive group.
- Override function available using Main/Auxiliary speed adjustment
- Related code: I 1 ~ I 5, I 6 ~ I10, I11 ~ I15

- ▶ Override function is to gain precise control and fast response by combining Main and Auxiliary speed input. Fast response can be achieved by Main speed and precise control can be accomplished by Aux. speed if the accuracy of Main/Aux speed is set differently.
- ▶ Follow the setting below when Main speed is given via 0 ~ 20mA with Aux. speed via V1 terminal (-10 ~ 10V).
- ▶ When override function is used, select the Main/Aux. speed according to loads used.

Group	Code	Parameter Name	Setting	Unit
I/O group	I 2	[NV input Min voltage]	0	V
	I 3	[Frequency corresponding to I 2]	0.00	Hz
	I 4	[NV input Max voltage]	10.00	V
	I 5	[Frequency corresponding to I 4]	5.00	Hz
	I 7	[V1 input Min voltage]	0	V
	I 8	[Frequency corresponding to I 7]	0.00	Hz
	I 9	[V1 input max voltage]	10	V
	I10	[Frequency corresponding to I 9]	5.00	Hz
	I12	[I input minimum current]	4	mA
	I13	[Frequency corresponding to I 12]	0.00	Hz
	I14	[I input max current]	20	mA
	I15	[Frequency corresponding to I 14]	60.00	Hz

- ▶ After the above setting is made, if 5V is applied to V1 with 12mA given to terminal I, output frequency would be 32.5Hz. If -5V is applied to V1 terminal with 12mA given to terminal I, output frequency would be 27.5Hz.

● Frequency setting via 0 ~ 10V + 0 ~ 20mA input

Group	Code	Parameter Name	Setting	Range	Initial	Unit
Drive group	0.00	[Frequency Command]	-	-	-	Hz
	Frq	[Frequency Mode]	6	0 ~ 7	0	

- Select 6 in Frq code of Drive group.
- Related code: I 6 ~ I 10, I 11 ~ I 15
- Refer to Frequency setting via -10 ~ +10V voltage input + 0 ~ 20mA input.

● Frequency setting via RS 485 communication

Group	Code	Parameter Name	Setting	Range	Initial	Unit
Drive group	0.0	[Frequency Command]	-	-	-	Hz
	Frq	[Frequency Mode]	7	0 ~ 8	0	

- Select 7 in Frq code of Drive group.
- Related code: I 59, I 60, I 61
- Refer to Chapter 13. RS485 communication.

● Analog Hold

Group	Code	Parameter Name	Setting	Range	Initial	Unit
Drive group	Frq	[Frequency Mode]	2 ~ 7	0 ~ 7	0	
I/O group	I17	[Multi-function input terminal P1 define]	-	0 ~ 24	0	
	~	~				
	I24	[Multi-function input terminal P8 define]	23		7	

- It is available when Frq code setting is 2 ~ 7.
- Select one terminal to use for Analog Hold command among Multi-function input terminal (P1 ~ P8).

▶ When P8 terminal is selected,

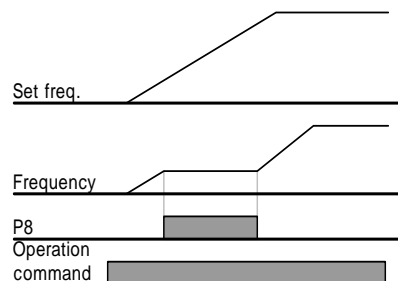

9.2 Multi-Step Frequency setting

Group	Code	Parameter Name	Setting	Range	Initial	Unit
Drive group	0.0	[Frequency Command]	5.0	0 ~ 400	0.0	Hz
	Frq	[Frequency Mode]	0	0 ~ 7	0	-
	St1	[Multi-Step frequency 1]	-	0 ~ 400	10.00	Hz
	St2	[Multi-Step frequency 2]	-		20.00	
	St3	[Multi-Step frequency 3]	-		30.00	
I/O group	I22	[Multi-function input terminal P6 define]	5	0 ~ 24	5	-
	I23	[Multi-function input terminal P7 define]	6		6	-
	I24	[Multi-function input terminal P8 define]	7		7	-
	I30	[Multi-Step frequency 4]	-	0 ~ 400	30.00	Hz
	I31	[Multi-Step frequency 5]	-		25.00	
	I32	[Multi-Step frequency 6]	-		20.00	
	I33	[Multi-Step frequency 7]	-		15.00	

- Select a terminal to give Multi-step frequency command among P1-P8 terminals.
- If terminals P6-P8 are selected, set I22-I24 to 5-7 to give Multi-step frequency command.
- Multi-step frequency 0 is settable in **Frq** – [Frequency mode] and **0.00** – [Frequency command].
- Multi-step frequency 1-3 are set at St1-St3 in Drive group, while Step frequency 4-7 are set at I30-I33 in I/O group.

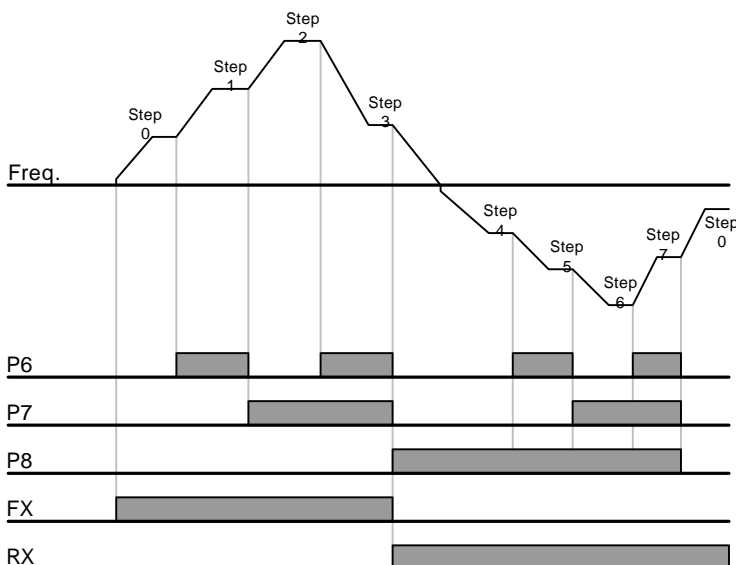

Step freq.	FX or RX	P8	P7	P6
0	✓	-	-	-
1	✓	-	-	✓
2	✓	-	✓	-
3	✓	-	✓	✓
4	✓	✓	-	-
5	✓	✓	-	✓
6	✓	✓	✓	-
7	✓	✓	✓	✓

9.3 Operating command setting method

- Operation via keypad RUN key and STOP/RST key

Group	Code	Parameter Name	Setting	Range	Initial	Unit
Drive group	drv	[Drive mode]	0	0 ~ 3	1	
	drC	[Direction of motor rotation select]	-	F, r	F	

- Set **drv** – [Drive mode] to 0.
- Acceleration is started upon pressing the Run key while operating frequency is set. Motor decelerates to stop by pressing the STOP/RST key.
- Selecting rotation direction is available at **drC** - [Direction of motor rotation select] when operating command is issued via keypad.

	F	Forward
	r	Reverse

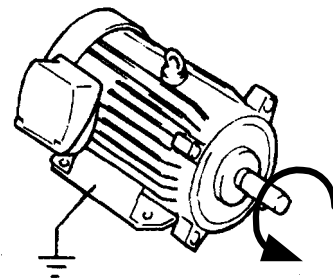

Forward :
Counter - clockwise

- ▶ When remote keypad is connected, body-embedded keypad is deactivated.

- Operating command via FX, RX terminal 1

Group	Code	Parameter Name	Setting	Range	Initial	Unit
Drive group	drv	[Drive mode]	1	0 ~ 3	1	
I/O group	I17	[Multi-function input terminal P1 define]	0	0 ~ 24	0	
	I18	[Multi-function input terminal P2 define]	1	0 ~ 24	1	

- Set **drv** – [Drive mode] to 1.
- Set I17 and I18 to 0 and 1 to use P1 and P2 as FX and RX terminals.
- “FX” is Forward run command and “RX” Reverse run.

- ▶ Motor is stopped when FX/RX terminal is ON/OFF at the same time.

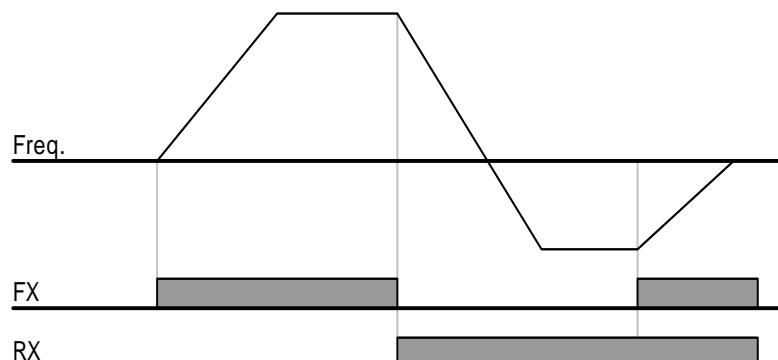

● Operating command via FX, RX terminal 2

Group	Code	Parameter Name	Setting	Range	Initial	Unit
Drive group	drv	[Drive mode]	2	0 ~ 3	1	
I/O group	I17	[Multi-function input terminal P1 define]	0	0 ~ 24	0	
	I18	[Multi-function input terminal P2 define]	1	0 ~ 24	1	

- Set the **drv** to 2.
- Set I17 and I18 to 0 and 1 to use P1 and P2 as FX and RX terminals.
- FX: Operating command setting. Motor runs in forward direction when RX terminal (P2) is OFF.
- RX: Direction of motor rotation select. Motor runs in reverse direction when RX terminal (P2) is ON.

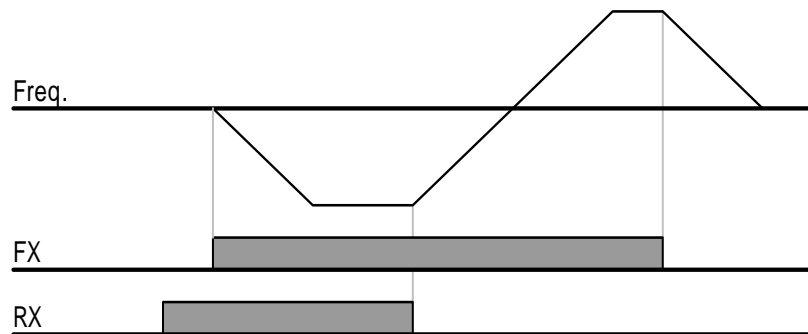

● Operating command via RS485 communication

Group	Code	Parameter Name	Setting	Range	Initial	Unit
Drive group	drv	[Drive mode]	3	0 ~ 3	1	
I/O group	I59	[Communication protocol select]	-	0 ~ 1	0	
	I60	[Inverter number]	-	1 ~ 32	1	
	I61	[Baud rate]	-	0 ~ 4	3	

- Set the **drv** to 3.
- Set I59, I60 and I61 correctly.
- Inverter operation is performed via RS485 communication.
- Refer to Chapter. 13, RS485 communication.

- Rotating direction select via -10 ~ +10[V] input of V1 terminal

Group	Code	Parameter Name	Setting	Range	Initial	Unit
Drive group	frq	[Frequency setting]	2	0 ~ 7	0	
Drive group	drv	[Drive mode]	-	0 ~ 3	1	

- Set **frq** to 2.
- Inverter is operating as the table below regardless of Drive mode setting.

	FWD RUN Command	REV RUN Command
0 ~ +10 [V]	FWD RUN	REV RUN
-10 ~ 0 [V]	REV RUN	FWD RUN

- ▶ Motor runs in Forward direction when input voltage to V1-CM is 0~10[V] and FWD RUN command is active. When input voltage polarity is reversed to -10~0[V] during FWD RUN, motor decelerates to stop and runs in reverse direction.
- ▶ When input voltage to V1-CM is 0~10[V] and REV RUN command is active, motor runs in Reverse direction and if -10~0[V] is input, motor rotating direction is reverse.

- FX/RX Run Disable

Group	Code	Parameter Name	Setting	Range	Initial	Unit
Drive group	drC	[Direction of motor rotation select]	-	F, r	F	
Function group 1	F 1	[Forward/Reverse run disable]	-	0 ~ 2	0	

- Select the direction of motor rotation.
- 0: Forward and Reverse run enable
- 1: Forward run disable
- 2: Reverse run disable

● Power On Start select

Group	Code	Parameter Name	Setting	Range	Initial	Unit
Drive group	drv	[Drive mode]	1, 2	0 ~ 3	1	
Function group 2	H20	[Power On Start select]	1	0 ~ 1	0	

- Set H20 to 1.
- When AC input power is applied to the inverter with drv set to 1 or 2 {Run via control terminal} ON, motor starts acceleration.
- This parameter is inactive when **drv** is set to 0 {Run via keypad} or 3 {RS485 communication}.

⚠ CAUTION
Particular attention must be directed to this function due to potential hazard as motor starts to run suddenly upon applying AC input power.

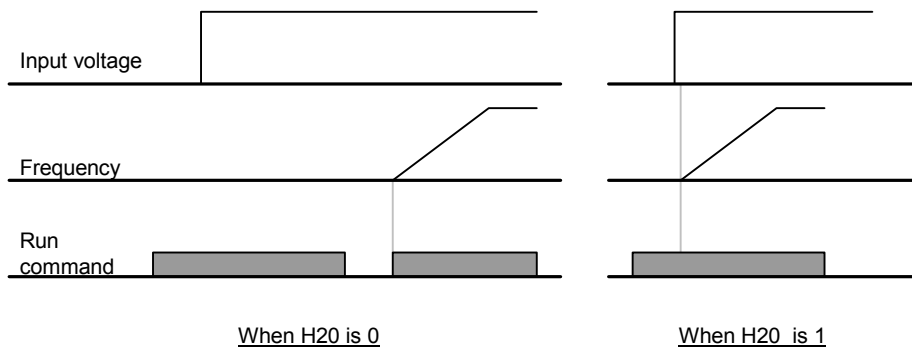

● Restart after fault reset

Group	Code	Parameter Name	Setting	Range	Initial	Unit
Drive group	drv	[Drive mode]	1, 2	0 ~ 3	1	
Function group 2	H21	[Restart after fault reset selection]	1	0 ~ 1	0	

- Set H21 to 1.
- Motor starts acceleration if **drv** is set to 1 or 2 and the selected terminal is ON when a fault is cleared.
- This parameter is inactive when **drv** is set to 0 {Run via keypad} or 3 {RS485 communication}.

⚠ CAUTION
Particular attention must be directed to this function due to potential hazard as motor starts to run suddenly after the fault is cleared.

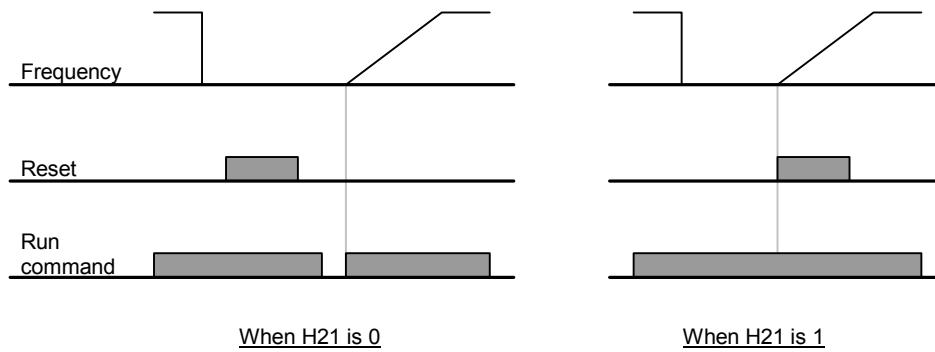

9.4 Accel/Decel time and pattern setting

- Accel/Decel time setting based on Max frequency

Group	Code	Parameter Name	Setting	Range	Initial	Unit
Drive group	ACC	[Accel time]	-	0 ~ 6000	5.0	Sec
	dEC	[Decel time]	-	0 ~ 6000	10.0	Sec
Function group1	F21	[Max Frequency]	-	0 ~ 400	60.00	Hz
Function group2	H70	[Frequency Reference for Accel/Decel]	0	0 ~ 1	0	
	H71	[Accel/Decel time scale]	-	0 ~ 2	1	

- Set the desired Accel/Decel time at ACC/dEC in Drive group.
- If H70 is set to 0 {Max frequency}, Accel/Decel time is the time that takes to reach the max freq from 0 Hz.
- Desired Accel/Decel time unit is settable at the H71.

- ▶ Accel/Decel time is set based on **F21** – [Max frequency]. For instance, if **F21** is set to 60Hz, Accel/Decel time 5 sec, and run frequency 30Hz, time to reach 30Hz would be 2.5 sec.

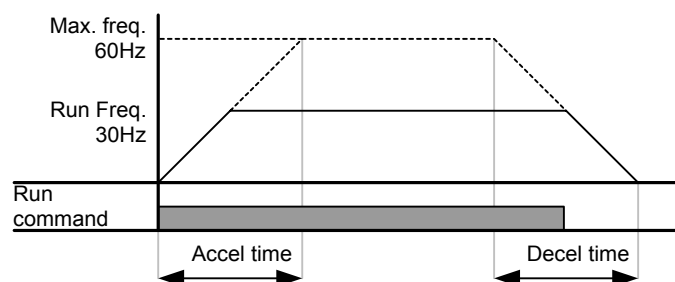

- ▶ More precise time unit can be set corresponding to load characteristics as shown below.
- ▶ In SV-iG5A, number display is available up to 5. Therefore, if time unit is set to 0.01 sec, Max Accel/Decel time would be 600.00 sec.

Code	Name	Set value	Setting range	Description
H71	[Accel/Decel time scale]	0	0.01~600.00	Setting Unit: 0.01 sec
		1	0.1~6000.0	Setting Unit: 0.1 sec
		2	1~60000	Setting Unit: 1 sec

● Accel/Decel time setting based on Operating Frequency

Group	Code	Parameter Name	Setting	Range	Initial	Unit
Drive group	ACC	[Accel time]	-	0 ~ 6000	5.0	Sec
	dEC	[Decel time]	-	0 ~ 6000	10.0	Sec
Function group 2	H70	[Frequency Reference for Accel/Decel]	1	0 ~ 1	0	

- Accel/Decel time is set at the **ACC/dEC**.
- If you set H70 to 1 {Delta frequency}, Accel/Decel time is the time that takes to reach a target freq from constant run freq (Current operating freq.).

- ▶ When H70 and Accel time are set to 1 {Delta frequency} and 5 sec, respectively,
- ▶ The below graph in Section A shows the change in operating frequency when target frequency is set to 10Hz at first and then changed to 30Hz.

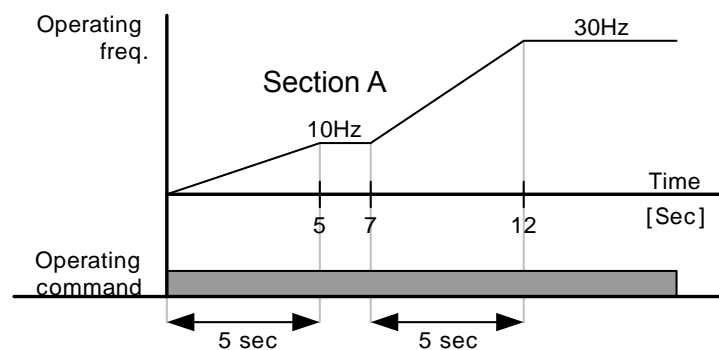

● Multi-Accel/Decel time setting via Multi-function terminals

Group	Code	Parameter Name	Set	Range	Initial	Unit
Drive group	ACC	[Accel time]	-	0 ~ 6000	5.0	Sec
	dEC	[Decel time]	-	0 ~ 6000	10.0	Sec
I/O group	I17	[Multi-function input terminal P1 define]	0	0 ~ 24	0	
	I18	[Multi-function input terminal P12 define]	1		1	
	I19	[Multi-function input terminal P3 define]	8		2	
	I20	[Multi-function input terminal P4 define]	9		3	
	I21	[Multi-function input terminal P5 define]	10		4	
	I34	[Multi-Accel time 1]	-	0 ~ 6000	3.0	Sec
	~	~				
I47	[Multi-Decel time 7]	-	9.0			

- Set I19, I20, I21 to 8, 9, 10 if you want to set Multi - Accel/Decel time via P3-P5 terminals.
- Multi-Accel/Decel time 0 is settable at ACC and dEC.
- Multi-Accel/Decel time 1-7 is settable at I34-I47.

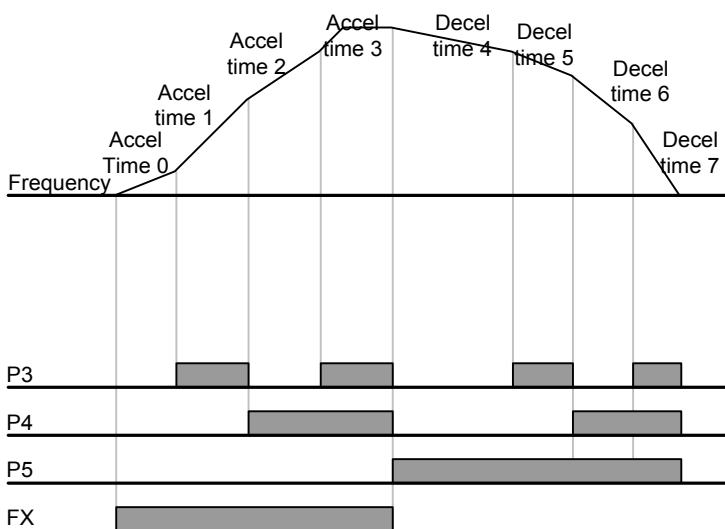

Accel/Decel time	P5	P4	P3
0	-	-	-
1	-	-	✓
2	-	✓	-
3	-	✓	✓
4	✓	-	-
5	✓	-	✓
6	✓	✓	-
7	✓	✓	✓

● Accel/Decel pattern setting

Group	Code	Parameter Name	Setting range	Initial	Unit
Function group1	F 2	[Accel pattern]	0	0	
	F 3	[Decel pattern]	1		
	H17	[S-Curve Accel/Decel start side]	0~100	40	%
	H18	[S-Curve Accel/Decel end side]		40	%

- Accel/Decel pattern is settable at F2 and F3.
- Linear: This is a general pattern for constant torque applications.
- S-curve: This curve allows the motor to accelerate and decelerate smoothly.

CAUTION :

- For S-curve, the actual Accel/Decel time takes longer than the time set by user.

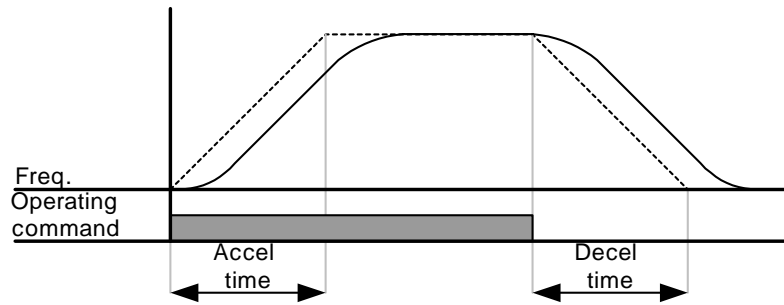

- ▶ H17 sets the starting ratio between S-curve and Linear in 1/2 of Accel/Decel Ref. Frequency. For smooth Accel/Decel starting, increase H17 to extend S-curve ratio.
- ▶ H18 sets the ending ratio between S-curve and Linear in 1/2 of Accel/Decel Ref. Frequency. For smooth and accurate speed arrival and stopping, increase H18 to extend S-curve ratio.

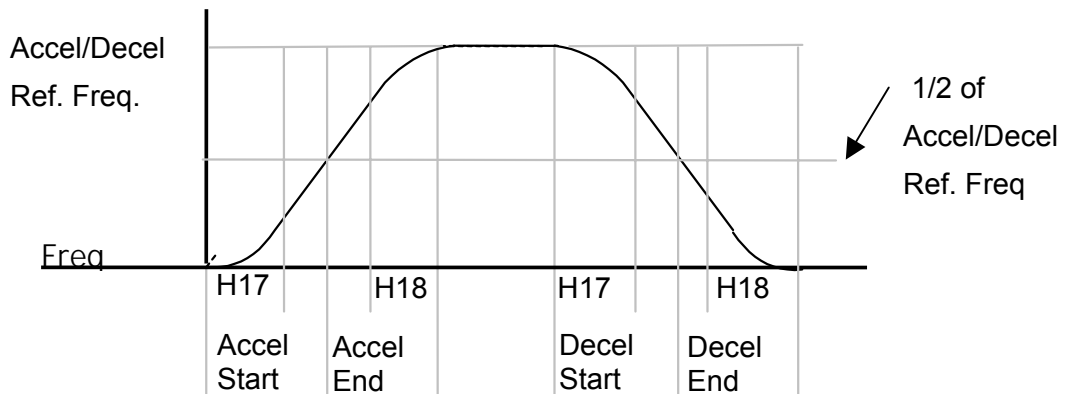

- ▶ Note that setting Frequency Ref. for Accel/decel (H70) is set to Max Freq and target freq is set below Max freq. the shape of S-curve may be distorted.

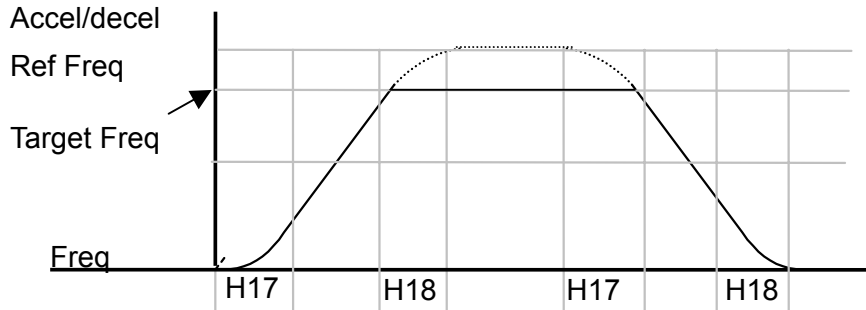

Note: If Target Frequency is below Max Frequency, the waveform will be shown with the top portion cut out.

- ▶ Accel time for S-curve setting

$$= ACC + ACC \times \frac{H17}{2} + ACC \times \frac{H18}{2}$$

- ▶ Decel time for S-curve setting

$$= dEC + dEC \times \frac{H17}{2} + dEC \times \frac{H18}{2}$$

- ▶ ACC, dEC indicate the set time in Drive group.

● Accel/Decel Disable

Group	Code	Parameter Name	Setting	Range	Initial	Unit
I/O group	I17	[Multi-function input terminal P1 define]	-	0 ~24	0	
	~	~				
	I24	[Multi-function input terminal P8 define]	24		7	

- Select one terminal among Multi-function input terminals 1-8 to define Accel/Decel disable.
- If P8 is selected, set I24 to 24 to activate this function.

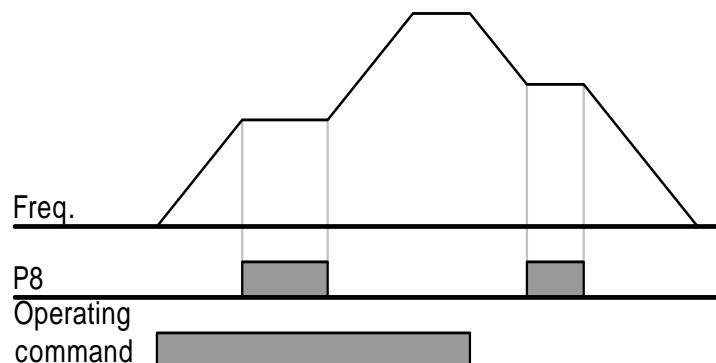

9.5 V/F control

- Linear V/F pattern operation

Group	Code	Parameter Name	Setting	Range	Initial	Unit
Function group1	F22	[Base frequency]	-	30 ~ 400	60.00	Hz
	F23	[Start frequency]	-	0 ~ 10.0	0.50	Hz
	F30	[V/F pattern]	0	0 ~ 2	0	
Function group2	H40	[Control mode select]	-	0 ~ 3	0	

- Set F30 to 0 {Linear}.
- This pattern maintains a linear Volts/frequency ratio from F23 - [Start frequency] to F22- [Base frequency]. This is appropriate for constant torque applications.

- ▶ Base Frequency: Inverter outputs its rated voltage at this level. Enter the motor nameplate frequency.
- ▶ Start Frequency: Inverter starts to output its voltage at this level.

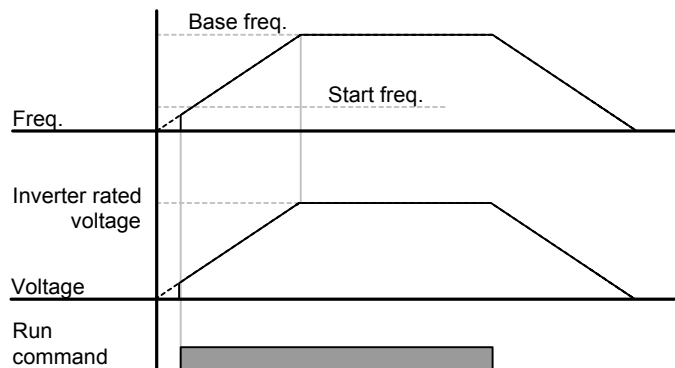

- Square V/F pattern

Group	Code	Parameter Name	Setting	Range	Initial	Unit
Function group1	F30	[V/F pattern]	1	0 ~ 2	0	

- Set F30 to 1{Square}.
- This pattern maintains squared volts/hertz ratio. Appropriate applications are fans, pumps, etc.

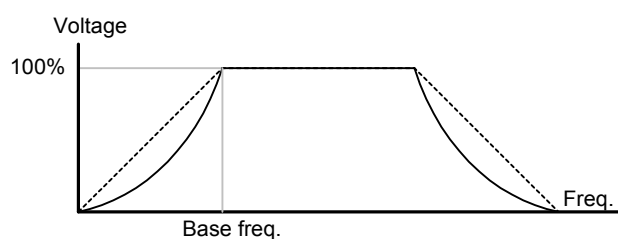

● User V/F pattern operation

Group	Code	Parameter Name	Setting	Range	Initial	Unit
Function group1	F30	[V/F pattern]	2	0 ~ 2	0	
	F31	[User V/F frequency 1]	-	0 ~ 400	15.00	Hz
	~	~				
	F38	[User V/F voltage 4]	-	0 ~ 100	100	%

- Select F30 to 2 {User V/F}.
- User can adjust the Volt/Frequency ratio according to V/F pattern of specialized motors and load characteristics.

CAUTION

In case of using a standard induction motor, if this value is set much higher than linear V/F pattern, it could result in torque shortage or motor overheating due to over-energizing. When User V/F pattern is active, F28 - [Torque Boost in forward direction] and F29 - [Torque Boost in reverse direction] are deactivated.

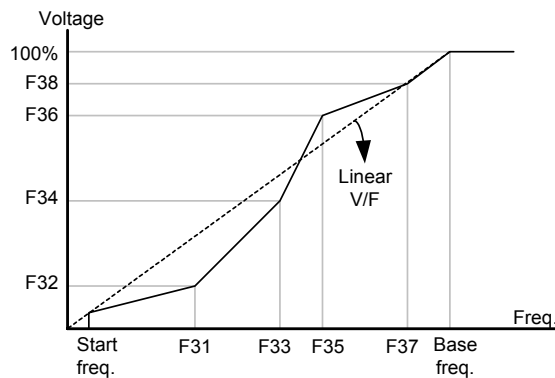

● Output voltage adjustment

Group	Code	Parameter Name	Setting	Range	Initial	Unit
Function group1	F39	[Output voltage adjustment]	-	40 ~ 110	100	%

- This function is used to adjust the output voltage of the inverter. This is useful when you use a motor that has a rated voltage lower than the input voltage.

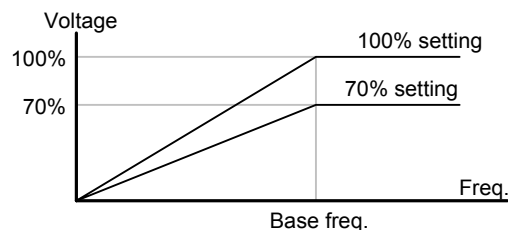

● Manual torque boost

Group	Code	Parameter Name	Setting	Range	Initial	Unit
Function group1	F27	[Torque Boost select]	0	0/1	0	
	F28	[Torque boost in forward direction]	-	0 ~ 15	5	%
	F29	[Torque boost in reverse direction]				

- Set F27 to 0 {Manual torque boost}.
- The values of [Torque boost in forward/reverse direction] are set separately in F28 and F29.

⚠ CAUTION
▪ If the boost value is set much higher than required, it may cause motor overheating due to over-energizing.

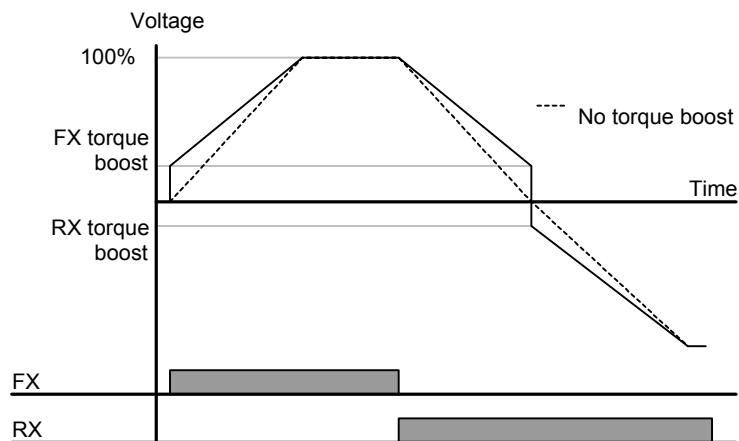

● Auto torque boost

Group	Code	Parameter Name	Setting	Range	Initial	Unit
Function group1	F27	[Torque Boost select]	1	0 ~ 1	0	
Function group1	H34	[No load motor Current]	-	0.1 ~ 12	-	A
	H41	[Auto tuning]	0	0 ~ 1	0	
	H42	[Stator resistance (Rs)]	-	0 ~ 14	-	Ω

- Before Auto Torque Boost setting, H34 and H42 should be set correctly (See page 10-6, 10-10).
- Select 1{Auto torque boost} in F27.
- Inverter automatically calculates torque boost value using motor parameters and outputs the corresponding voltage.

9.6 Stop method select

- Decel to stop

Group	Code	Parameter Name	Setting	Range	Initial	Unit
Function group1	F4	[Stop mode select]	0	0 ~ 2	0	

- Select 0 {decel to stop} in F30.
- Motor decelerates to 0 Hz and stops during the setting time.

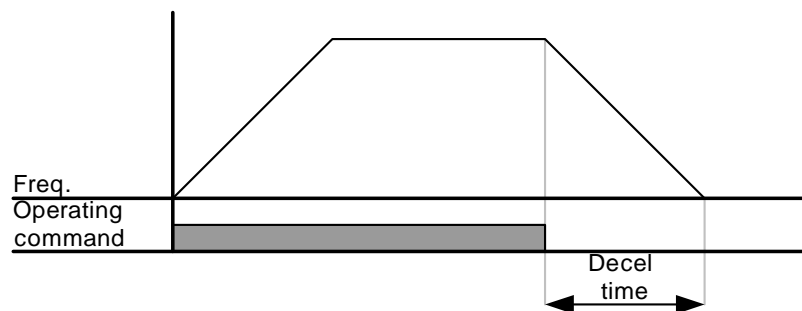

- DC braking to stop

Group	Code	Parameter Name	Setting	Range	Initial	Unit
Function group1	F4	[Stop mode select]	1	0 ~ 2	0	

- Select 1 {DC brake to stop} in F30 code.
- Refer to page 10-1.

- Free run stop

Group	Code	Parameter Name	Setting	Range	Initial	Unit
Function group1	F4	[Stop mode select]	2	0 ~ 2	0	

- Select 2 {Free run stop} in F30 code.
- When operating command is turned OFF, Output Frequency and voltage are shut down.

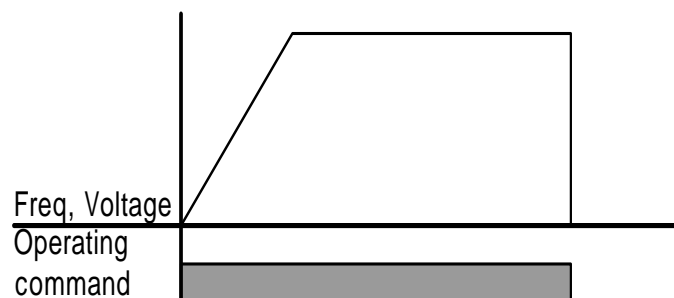

9.7 Frequency limit

- Frequency limit using Max Frequency and Start Frequency

Group	Code	Parameter Name	Setting	Range	Initial	Unit
Function group1	F21	[Max frequency]	-	0 ~ 400	60.00	Hz
	F23	[Start frequency]	-	0 ~ 10	0.50	Hz

- Max Frequency: Frequency highest limit. Any frequency cannot be set above [Max frequency] except for F22 [Base frequency].
- Start Frequency: Frequency lowest limit. If a frequency is set lower than this, 0.00 is automatically set.

- Frequency command limit using High/Low limit

Group	Code	Parameter Name	Setting	Range	Initial	Unit
Function group1	F24	[Frequency high/low limit select]	1	0 ~ 1	0	
	F25	[Frequency high limit]	-	0 ~ 400	60.00	Hz
	F26	[Frequency low limit]	-	0 ~ 400	0.50	Hz

- Set F24 to 1.
- Active run frequency can be set within the range of F25 and F26.

▶ When frequency setting is done via Analog input (voltage or current input), the inverter operates within the range of high and low limit frequency as shown below.

▶ This setting is also valid when frequency setting is done via keypad.

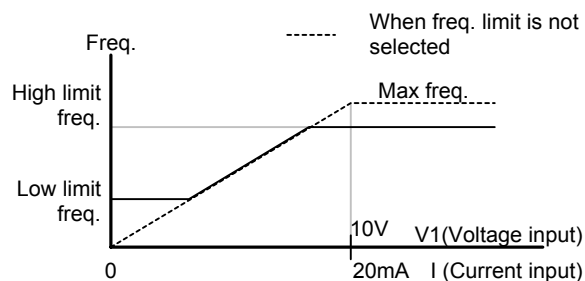

● Skip frequency

Group	Code	Parameter Name	Setting	Range	Initial	Unit
Function group2	H10	[Skip frequency select]	1	0 ~ 1	0	
	H11	[Skip frequency low limit 1]	-	0 ~ 400	10.00	Hz
	~	~				
	H16	[Skip frequency low limit 3]	-	0 ~ 400	35.00	Hz

- Set H10 to 1.
- Run frequency setting is not available within the skip frequency range of H11-H16.
- Skip frequency is settable within the range of F21 – [Max frequency] and F23 – [Start frequency].

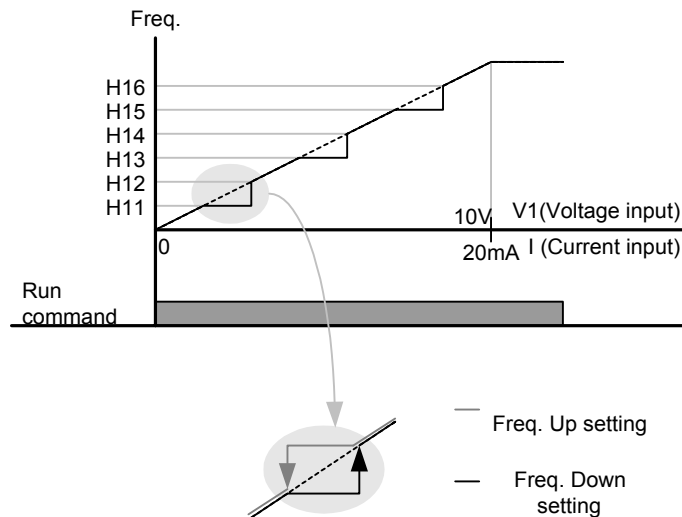

- ▶ When it is desired to avoid resonance attributable to the natural frequency of a mechanical system, these parameters allow resonant frequencies to be skipped. Three different areas of [Skip frequency High/Low limit] can be set with the skip frequencies set to either the top or bottom point of each area. However, during acceleration or deceleration, the run frequency within the set area is valid.
- ▶ In the case of increasing frequency setting as shown above, if frequency set value (Analog setting via voltage, current, or digital setting via keypad) is within the range of Skip frequency, it maintains Skip freq RS485 communication, frequency low limit value. If the set value is outside the range, it increases the frequency.
- ▶ In the case of decreasing frequency setting, if frequency set value (Analog setting via voltage, current, RS485 communication, or Digital setting via keypad) is within the range of Skip frequency, it maintains Skip frequency high limit value. If the set value is outside the range, it decreases the frequency.

CHAPTER 10 - ADVANCED FUNCTIONS

10.1 DC brake

- Stopping motor by DC brake

Group	Display	Parameter Name	Setting	Min/Max	Default	Unit
F 1	F 4	[Stop mode select]	1	0 ~ 2	0	
	F 8	[DC Brake start frequency]	-	0 ~ 60	5.00	Hz
	F 9	[DC Brake wait time]	-	0 ~ 60	0.1	sec
	F10	[DC Brake voltage]	-	0 ~ 200	50	%
	F11	[DC Brake time]	-	0 ~ 60	1.0	sec

- Set F4 - [Stop mode select] to 1.
- F 8: The frequency at which the DC brake will become active.
- F 9: Inverter output will hold for this time after F8 - [DC Brake start frequency] before applying F10 - [DC Brake voltage].
- F10: Set this value as a percent of H33 – [Motor rated current].
- F11: It sets the time for F10 - [DC Brake voltage] to be applied to the motor after F 9 - [DC Brake wait time].

Caution:

If excessive DC Brake voltage is set or DC Brake time is set too long, it may cause motor overheating and damage to the motor.

- ▶ Setting F10 or F11 to 0 will disable DC brake.
- ▶ F 9 – [DC Brake Wait time]: When load inertia is large or F 8 – [DC Brake Start Frequency] is high, over current trip may occur. It can be prevented using F9.

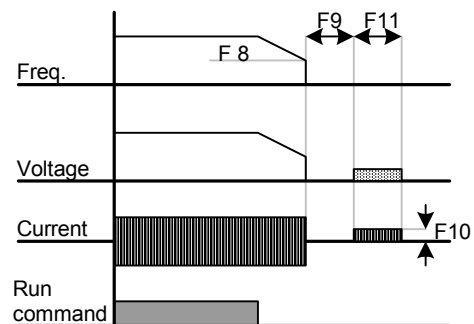

- ▶ In case of DC brake at high load inertia and frequency, change the DC brake controller gain according to H37 set value.

H37	Load inertia ratio	Setting	Description
		0	Less than 10 times motor inertia
		1	10 times motor inertia
		2	Greater than 10 times motor inertia

● Starting DC brake

Group	Display	Parameter Name	Setting	Min/Max	Default	Unit
F 1	F12	[DC Brake start voltage]	-	0 ~ 200	50	%
	F13	[DC Brake start time]	-	0 ~ 60	0	sec

- F12: It sets the level as a percent of H33 – [Motor rated current].
- F13: Motor accelerates after DC voltage is applied for the set time.

Caution:
If excessive DC Brake voltage is set or DC Brake time is set too long, it may cause motor overheating and damage to the motor.

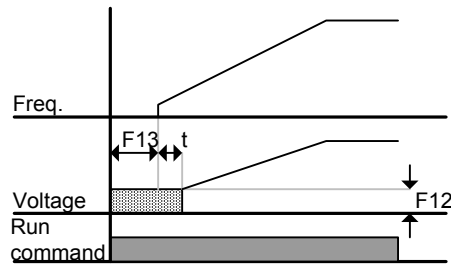

- ▶ Setting F12 or F13 to 0 will disable Starting DC brake.
- ▶ t: After F13 - [DC Brake start time], the frequency is increasing after DC voltage is applied until the time t.

● DC brake at a stop

Group	Display	Parameter Name	Setting	Min/Max	Default	Unit
F 1	F12	[DC Brake start voltage]	-	0 ~ 200	50	%
I/O	I19	[Multi-function Input terminal P3 Function select]	11	0 ~ 24	2	

- F12: It sets the level as a percent of H33 – [Motor rated current].
- Select a terminal to issue a command of DC brake at a stop among P1 to P8.
- If P3 terminal is set for this function, set I19 to 11 {DC brake during stop}.

Caution:
If excessive DC Brake voltage is set or DC Brake time is set too long, it may cause motor overheating and damage to the motor.

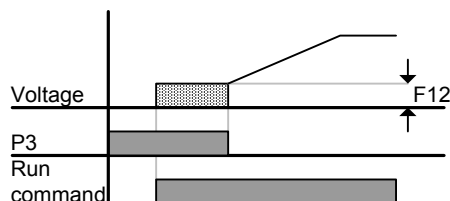

10.2 Jog operation

Group	Display	Parameter Name	Setting	Min/Max	Default	Unit
F 1	F20	[Jog frequency]	-	0 ~ 400	10.00	Hz
I/O	I21	[Multi-function input terminal P5 define]	4	0 ~ 24	4	

- Set the desired jog frequency in F20.
- Select a terminal from P1 - P8 to use for this setting.
- If P5 is set for Jog operation, set I21 to 4 {Jog}.
- Jog frequency can be set within the range of F21 - [Max frequency] and F22 – [Start frequency].

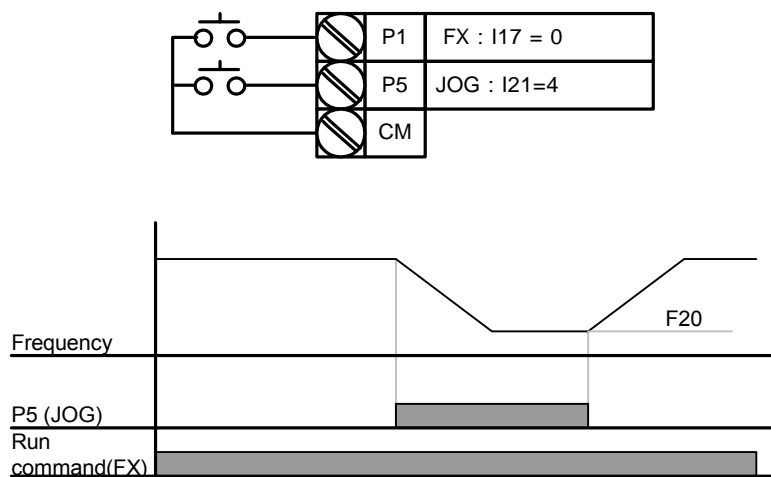

- ▶ Jog operation overrides all other operations except Dwell operation. Therefore, if Jog frequency command is entered in the middle of Multi-Step, Up-Down or 3-wire operation, operation is executed at Jog frequency.
- ▶ The above diagram is an example when Multi-function input is set to NPN mode.

10.3 UP – DOWN

Group	Display	Parameter Name	Setting	Min/Max	Default	Unit
I/O	I17	[Multi-function Input terminal P1 select]	0	0 ~ 24	2	
	~	~				
	I23	[Multi-function Input terminal P7 select]	15		6	
	I24	[Multi-function Input terminal P8 select]	16		7	

- Select terminals for Up-Down operation from P1-P8.
- If P7 and P8 are selected, set I23 and I24 to 15 {Frequency Up command} and 16 {Frequency Down command}, respectively.

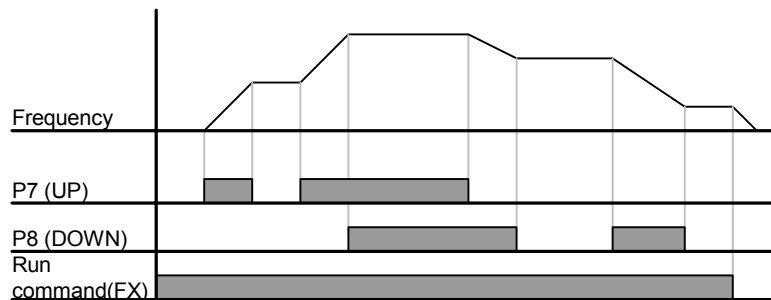
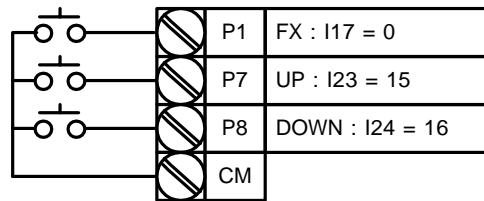

10.4 3-Wire

Group	Display	Parameter Name	Setting	Min/Max	Default	Unit
I/O	I17	[Multi-function Input terminal P1 select]	0	0 ~ 24	2	
	~	~				
	I24	[Multi-function Input terminal P8 select]	17		7	

- Select the terminal from P1-P8 for use as 3-Wire operation.
- If P8 is selected, set I24 to 17 {3-Wire operation}.

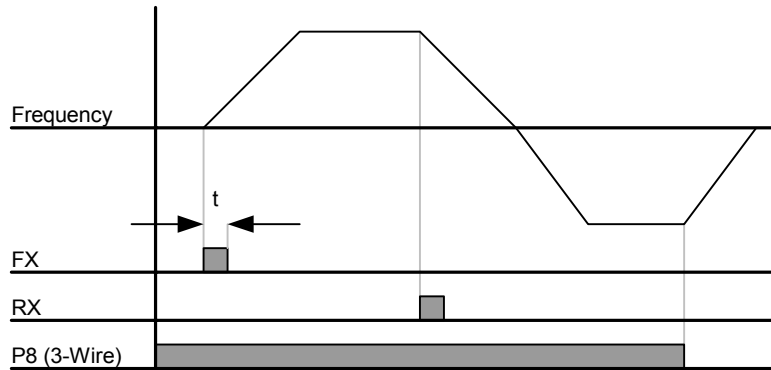
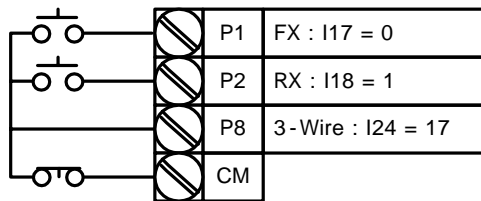

- ▶ Input signal is latched (saved) in 3-Wire operation. Therefore, inverter can be operated by Push-button switch.
- ▶ The bandwidth of pulse (t) should not be less than 50msec.

10.5 Dwell operation

Group	Display	Parameter Name	Setting	Min/Max	Default	Unit
Function group 2	H 7	[Dwell frequency]	-	0 ~ 400	5.00	Hz
	H 8	[Dwell time]	-	0 ~ 10	0.0	sec

- In this setting, motor begins to accelerate after dwell operation is executed for dwell time at the dwell frequency.
- It is mainly used to release mechanical brake in elevators after operating at dwell frequency.

- ▶ Dwell frequency: This function is used to output torque in an intended direction. It is useful in hoisting applications to get enough torque before releasing a mechanical brake. Rated Slip frequency is calculated by the formula shown below.

$$f_s = f_r - \left(\frac{rpm \times P}{120} \right)$$

Where, f_s = Rated slip frequency

f_r = Rated frequency

rpm = Motor nameplate RPM

P = Number of Motor poles

Example

Rated frequency = 60Hz

Rated RPM = 1740rpm

Number of motor poles= 4

$$f_s = 60 - \left(\frac{1740 \times 4}{120} \right) = 2Hz$$

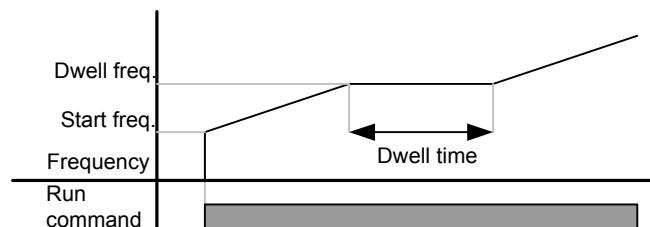

10.6 Slip compensation

Group	Display	Parameter Name	Setting	Min/Max	Default	Unit
F 2	H30	[Motor type select]	-	0.2 ~ 7.5	7.5	
	H31	[Number of motor poles]	-	2 ~ 12	4	
	H32	[Rated slip frequency]	-	0 ~ 10	2.33	Hz
	H33	[Motor rated current]	-	1.0 ~ 50	26.3	A
	H34	[Motor No Load Current]	-	0.1 ~ 20	11.0	A
	H36	[Motor efficiency]	-	50 ~ 100	87	%
	H37	[Load inertia rate]	-	0 ~ 2	0	
	H40	[Control mode select]	1	0 ~ 3	0	

- Set H40 – [Control mode select] to 1 {Slip compensation}.
- This function enables the motor to run in constant speed by compensating inherent slip in an induction motor.

▶ H30: Set the motor type connected to the inverter output side.

H30	[Motor type select]	0.2	0.2kW
		~	
		5.5	5.5kW
		7.5	7.5kW

- ▶ H31: Enter the pole number on the Motor nameplate.
- ▶ H32: Enter the slip frequency in accordance with the following formula and motor nameplate.

$$f_s = f_r - \left(\frac{rpm \times P}{120} \right)$$

Where, f_s = Rated slip frequency

f_r = Rated frequency

rpm = Motor rated RPM

P = Motor pole number

Ex) Rated freq.: 60Hz, Rated RPM: 1740rpm, Poles: 4,

$$f_s = 60 - \left(\frac{1740 \times 4}{120} \right) = 2Hz$$

- ▶ H33: Enter the motor nameplate rated current.
- ▶ H34: Enter the measured current when the motor is running at rated frequency after the load is removed. Enter 50% of the rated motor current when it is difficult to measure the motor no load current.
- ▶ H36: Enter motor efficiency on the nameplate.
- ▶ H37: Select load inertia based on motor inertia as shown below.

H37	[Load inertia rate]	0	Less than 10 times motor inertia
		1	About 10 times motor inertia
		2	Greater than 10 times motor inertia

- ▶ As the loads are heavier, the speed gap between rated RPM and synchronous speed is widening (see the figure below). This function compensates for this inherent slip.

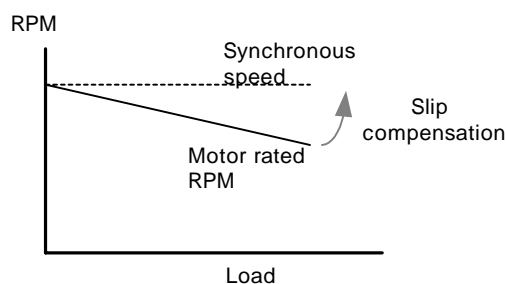

10.7 PID control

Group	Display	Parameter Name	Setting	Min/Max	Default	Unit
F 2	H40	[Control mode select]	2	0 ~ 3	0	-
	H50	[PID Feedback select]	-	0 ~ 1	0	-
	H51	[P gain for PID controller]	-	0 ~ 999.9	300.0	%
	H52	[Integral time for PID controller (I gain)]	-	0.1~ 32.0	1.0	sec
	H53	[Differential time for PID controller (D gain)]	-	0.0~30.0	0	sec
	H54	[F gain for PID controller]	-	0 ~ 999.9	0	%
	H55	[PID output frequency limit]	-	0 ~ 400	60.0	Hz
	I17~ I24	[Multi-function input terminal P1-P8 define]	21	0 ~ 24	-	-
Drive	rPM	[Motor RPM]				

- Set H40 to 2 {PID Feedback control}.
- Output frequency of the inverter is controlled by PID control for use as constant control of flow, pressure or temperature.

- ▶ H50: Select the feedback type of PID controller.

H50	[PID Feedback select]	0	Terminal I input (0 ~ 20[mA])
		1	Terminal V1 input (0 ~ 10[V])

- ▶ H51: Set the percentage of output to error. If P Gain is set to 50%, 50% of the error value will be output. Higher value can reach the target control value faster but it may cause oscillation.
- ▶ H52: Set the time to output the accumulated error value. Set the time required to output 100% when the error value is 100%. If H52 - [Integral time for PID controller (I gain)] is set to 1 sec and the error becomes 100%, 100% will be output in 1 sec. Adjusting the value may reduce the nominal error. If the value is reduced, response will be faster but setting too low may lead to controller oscillation.
- ▶ H53: Set the output value to the variation of the error. The error is detected by 0.01 sec in SV-iG5A. If differential time is set to 0.01 sec and the percentage variation of error per 1 sec is 100%, 1% per 10msec is output.
- ▶ H54: PID Feed Forward Gain. Set the gain to add the target value to the PID controller output.
- ▶ H55: It limits the output of the PID controller.
- ▶ I17 ~ I24: To exchange PID to normal operation, set one of P1-P8 terminal to 21 and turn ON.
- ▶ rPM: Calculates the feedback from H50 into Frequency and displays it.

▪ PID block diagram

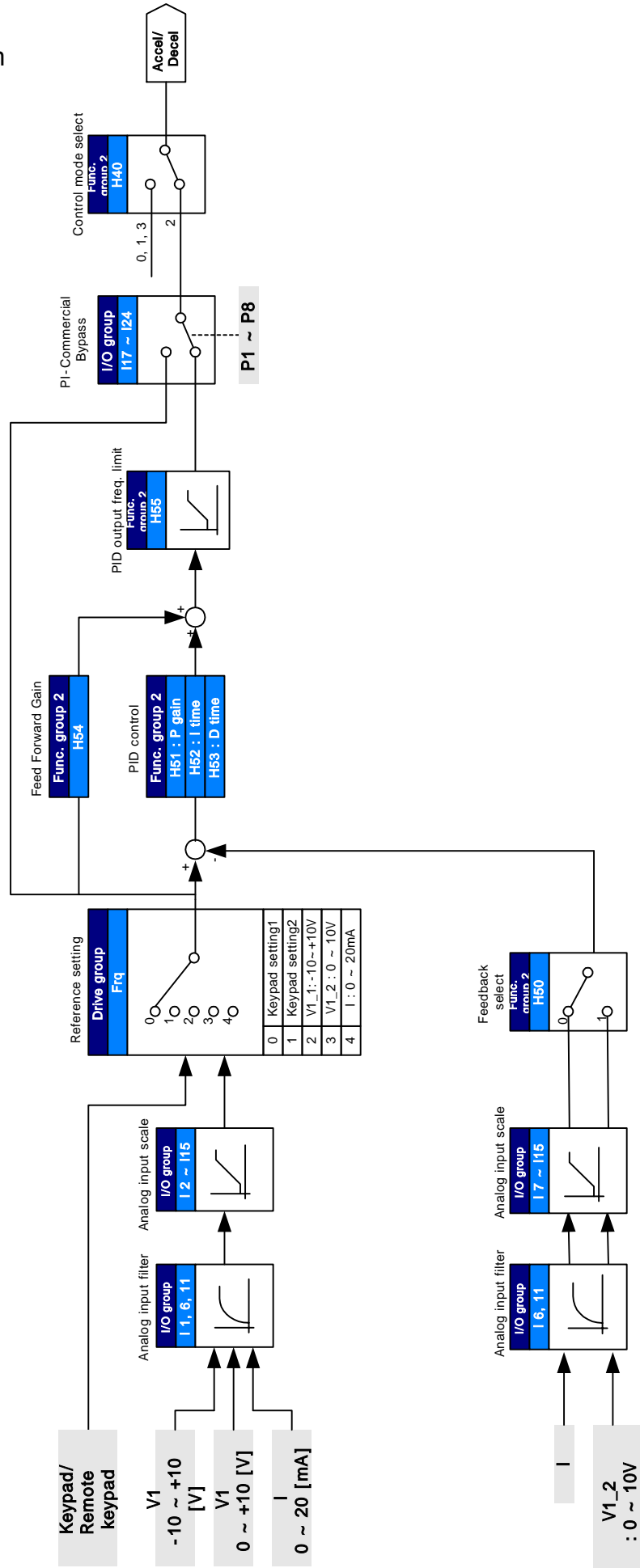

10.8 Auto-tuning

Group	Display	Parameter Name	Setting	Min/Max	Default	Unit
F 2	H41	[Auto tuning]	1	0 ~ 1	0	-
	H42	[Stator resistance (Rs)]	-	0 ~ 14	-	Ω
	H44	[Leakage inductance (L σ)]	-	0 ~ 300.00	-	mH

- Automatic measuring of the motor parameters is provided.
- The measured motor parameters in H41 can be used in Auto Torque Boost and Sensorless Vector Control.

Caution:

Auto tuning should be executed after stopping the motor. Motor shaft must not run by the load during H41 – [Auto tuning].

- ▶ H41: When H41 is set to 1 and press the Enter (●) key, Auto tuning is activated and “TUn” will appear on the LED keypad. When finished, “H41” will be displayed.
- ▶ H42, H44: The values of motor stator resistance and leakage inductance detected in H41 are displayed, respectively. When Auto tuning is skipped or H93 – [Parameter initialize] is done, the default value corresponding to motor type (H30) will be displayed.
- ▶ Press the STOP/RST key on the keypad or turn on the EST terminal to stop the Auto Tuning.
- ▶ If Auto tuning of H42 and H44 is interrupted, the default value will be set. If H42 and H44 are finished and auto-tuning of leakage inductance is interrupted, the measured value of H42 and H44 are used and the default of leakage inductance is set.
- ▶ See page 10-12 for motor parameter default values.

Caution:

Do not enter any incorrect value as stator resistance and leakage inductance. Otherwise, the function of Sensorless vector control and Auto torque boost could be deteriorated.

10.9 Sensorless Vector Control

Group	Display	Parameter Name	Setting	Min/Max	Default	Unit
F 2	H40	[Control mode select]	3	0 ~ 3	0	-
	H30	[Motor type select]	-	0.2 ~ 7.5	-	kW
	H32	[Rated slip frequency]	-	0 ~ 10	-	Hz
	H33	[Motor rated current]	-	1.0 ~ 50	-	A
	H34	[Motor No Load Current]	-	0.1 ~ 20	-	A
	H42	[Stator resistance (Rs)]	-	0 ~ 14	-	Ω
	H44	[Leakage inductance (L σ)]	-	0~300.00	-	mH
	F14	[Time for energizing a motor]	-	0.0~60.0	1.0	sec

- If H40 – [Control mode select] is set to 3, Sensorless vector control will become active.

Caution:

Motor parameters should be measured for high performance. It is highly recommended H41 – [Auto tuning] be done prior to proceeding operation via Sensorless vector control.

- ▶ Ensure that the following parameters are entered correctly for high performance in Sensorless vector control.
- ▶ H30: Select motor type connected to inverter output.
- ▶ H32: Enter rated slip frequency based on motor nameplate RPM and rated frequency (See 10-6).
- ▶ H33: Enter motor nameplate rated current.
- ▶ H34: After removing the load, select H40 – [Control mode select] to 0 {V/F control} and run the motor at 60Hz. Enter the current displayed in Cur-[Output current] as motor no load current. If it is difficult to remove the load from the motor shaft, enter the value either 40 to 50% of the H33 – [Motor rated current] or the factory default.
- ▶ H42, H44: Enter the value of the parameter measured during H41 – [Auto tuning] or the factory default.
- ▶ F14: This parameter accelerates the motor after pre-exciting the motor for the set time. The amount of the pre-exciting current is set in H34- [Motor no load current].
- ▶ Directly enter the motor nameplate value except motor rating when 0.2kW is used.

■ Factory default by motor ratings

Input voltage	Motor rating [kW]	Current rating [A]	No-load current [A]	Rated slip freq [Hz]	Stator resistance [Ω]	Leakage inductance [mH]
200	0.2					
	0.4					
	0.75					
	1.5					
	2.2					
	3.7					
	5.5	19.7	6.6	2.33	0.314	3.60
	7.5	26.3	9.0	2.33	0.169	2.89
400	0.2					
	0.4					
	0.75					
	1.5					
	2.2					
	3.7					
	5.5	9.9	3.9	2.33	0.940	10.74
	7.5	15.2	5.7	2.33	0.520	8.80

10.10 Energy-saving operation

Group	Display	Parameter Name	Setting	Min/Max	Default	Unit
F 1	F40	[Energy-saving operation]	-	0 ~ 30	0	%

- Set the amount of output voltage to be reduced in F40.
- Set as the percent of Max output voltage.
- For fan or pump applications, energy consumption can be dramatically reduced by decreasing the output voltage when light or no load is connected.

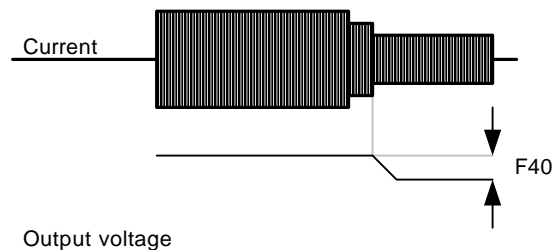

10.11 Speed search

Group	Display	Parameter Name	Setting	Min/Max	Default	Unit
F 2	H22	[Speed search select]	-	0 ~ 15	0	
	H23	[Current level]	-	80 ~ 200	100	%
	H24	[Speed search P gain]	-	0 ~ 9999	100	
	H25	[Speed search I gain]	-		1000	
I/O	I54	[Mfi output terminal]	15	0 ~ 18	12	
	I55	[Multi-function relay]	15		17	

- This is used to prevent possible fault from occurring if the inverter outputs the voltage during operation after the load is removed.
- The inverter estimates the motor rpm based on output current. Therefore, detecting exact speed is difficult.

The following table shows 4 types of Speed search selection.

H22	Speed search during H20 – [Power ON start]	Speed search during Instant Power Failure restart	Speed search during H21- [Restart after fault reset]	Speed search during Acceleration
	Bit 3	Bit 2	Bit 1	Bit 0
0	-	-	-	-
1	-	-	-	✓
2	-	-	✓	-
3	-	-	✓	✓
4	-	✓	-	-
5	-	✓	-	✓
6	-	✓	✓	-
7	-	✓	✓	✓
8	✓	-	-	-
9	✓	-	-	✓
10	✓	-	✓	-
11	✓	-	✓	✓
12	✓	✓	-	-
13	✓	✓	-	✓
14	✓	✓	✓	-
15	✓	✓	✓	✓

- ▶ H23: Limits current during Speed search. Set as the percent of H33.
- ▶ H24, H25: Speed search is activated via PI control. Adjust P gain and I gain corresponding to the load characteristics.
- ▶ I54, I55: Signal of active Speed search is given to external sequence via Multi-function output terminal (MO) and Multi-function relay output (3AC).

EX) Speed search during Instant Power Failure restart

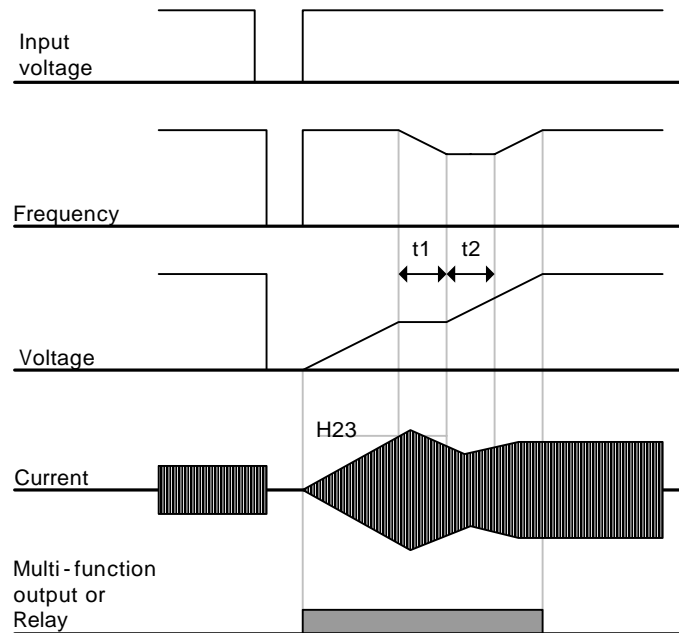

- When the input power is cut off due to instant power failure, the inverter outputs Low voltage trip (LV) to hold the output.
 - When the power is restored, the inverter outputs the frequency before the low voltage trip and the voltage is increased due to PI control.
 - t1: If current is increasing over the preset level in H23, the rise in voltage will stop and the frequency is decreased.
 - t2: If the opposite of t1 occurs, the increase in voltage starts again and the decrease in frequency stops.
 - When the frequency and voltage are restored back to the nominal level, acceleration will continue at the frequency before trip.
-
- ▶ Speed search operation is suitable for loads with high inertia. Stop the motor and restart when friction in load is high.
 - ▶ SV-iG5A keeps normal operation when instant power failure occurs and power is restored in 15msec for the use of its inverter rating.
 - ▶ Inverter DC link voltage can vary depending on output load quantity. Therefore, Low Voltage trip may occur when instant power failure is maintained over 15msec or output is higher than its rating.
 - ▶ Instant power failure specification is applied when input voltage to Inverter is 200~230V AC for 200V class, or 380~460V AC for 400V class.

10.12 Auto restart try

Group	Display	Parameter Name	Setting	Min/Max	Default	Unit
F 2	H26	[Number of Auto Restart try]	-	0 ~ 10	0	
	H27	[Auto Restart time]	-	0 ~ 60	1.0	sec

- This parameter sets the number of times auto restart is activated in H26.
- It is used to prevent the system down caused by internal protection function activated by the causes such as noise.

- ▶ H26: Auto restart will become active after the H27. H26 – [Number of Auto restart try] is reduced by 1 when it is active. If the trip outnumbers the preset restart try, auto restart function is deactivated. If the setting is reset via the control terminal or the STOP/RST key on the keypad, the number of auto restart try set by user is automatically entered.
- ▶ If there is no more trip occurring for 30 sec after Auto restart operation, the H26 is restored to the preset value.
- ▶ When operation is stopped due to Low voltage {Lvt}, Emergency stop {EST}, Inverter Overheat {Oht}, and Hardware Trip {HWt}, Auto restart will be deactivated.
- ▶ After the H27- [Auto Restart time], the motor starts acceleration automatically via speed search (H22-25).
- ▶ The following pattern is shown when the H26 – [Number of auto restart try] is set to 2.

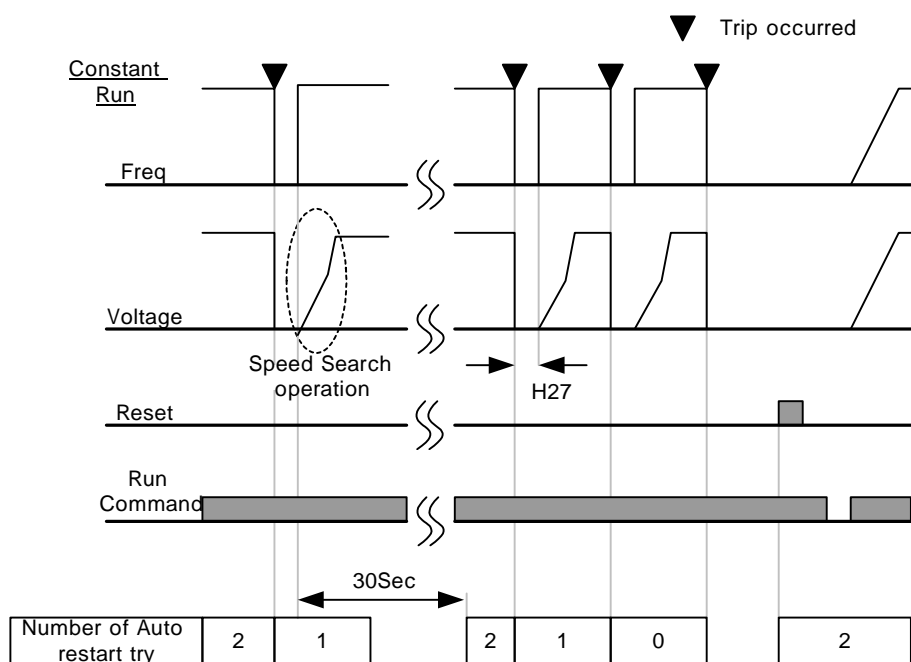

10.13 Operating sound select (Carrier frequency change)

Group	Display	Parameter Name	Setting	Min/Max	Default	Unit
F 2	H39	[Carrier frequency]	-	1 ~ 15	3	

- This parameter affects the sound of the inverter during operation.

H39	When setting carrier frequency high,	Motor sound reduced
		Inverter heat loss increased
		Inverter noise increased
		Inverter leakage current increased

10.14 2nd motor operation

Group	Display	Parameter Name	Setting	Min/Max	Default	Unit
F 2	H81	[2nd motor accel time]	-	0 ~ 6000	5.0	sec
	H82	[2nd motor decel time]	-	0 ~ 6000	10.0	sec
	H83	[2nd motor base freq.]	-	30 ~ 400	60.00	Hz
	H84	[2nd motor V/F pattern]	-	0 ~ 2	0	
	H85	[2nd motor Positive torque boost]	-	0 ~ 15	5	%
	H86	[2nd motor Negative torque boost]	-	0 ~ 15	5	%
	H87	[2nd motor stall prevention level]	-	30 ~ 150	150	%
	H88	[2nd motor electronic thermal level for 1 min]	-	50 ~ 200	150	%
	H89	[2nd motor electronic thermal level for continuous operation]	-	50 ~ 200	100	%
	H90	[2nd motor rated current]	-	1 ~ 50	26.3	A
I/O	I17	[Multi-function Input terminal P1Function select]	-	0 ~ 24	0	
	~	~				
	I24	[Multi-function Input terminal P8Function select]	12		7	

- **Set the terminal among Multi-function input P1 thru P5 for second motor operation.**
- To define the terminal P5 as second motor operation, set I24 to 12.

- ▶ Used when an inverter operates 2 motors connected to two different types of the loads.
- ▶ **2nd motor operation does not drive 2 motors at the same time.**
- ▶ As the figure below, when using two motors with an inverter by exchanging them, select one motor from 2 motors connected. When 1st selected motor operation is stopped, select a terminal for 2nd motor and define H81-H90 parameters to drive the 2nd motor.
- ▶ Define the 2nd motor select when a motor is stopped.
- ▶ H81 ~ H90 parameters function the same as 1st motor.

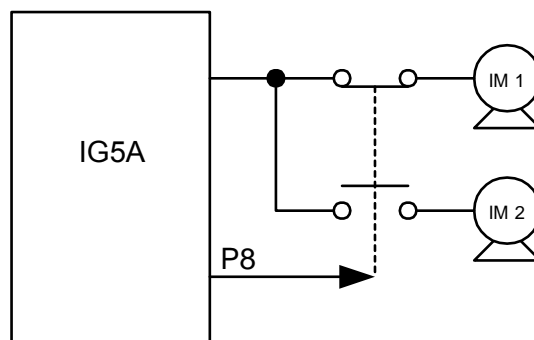

10.15 Cooling fan control

Group	Display	Parameter Name	Setting	Min/Max	Default	Unit
F 2	H77	Cooling fan control	1	0 ~ 1	0	

- Control the On/ Off of the cooling fan to cool the Inverter heatsink.
-

▶ When it is set to 0:

- . Cooling fan begins to operate when power ON.
- . Cooling fan is stopped when inverter main circuit voltage becomes low voltage due to power off.

▶ When it is set to 1:

- . Cooling fan begins to operate when power is turned ON with operating command ON.
- . Cooling fan is stopped when operating command is turned Off with inverter output shut off.
- . Cooling fan keeps operating when heat sink temperature exceeds a certain limit regardless of operating command.
- . Used when frequent Run/Stop or quite stop is required. This may make the cooling fan life longer.

10.16 Operating mode select when cooling fan trip occurs

Group	Display	Parameter Name	Setting	Min/Max	Default	Unit
F 2	H78	[Operating mode when cooling fan trip occurs]	-	0 ~ 1	0	-
I/O	I54	[Multi-function output terminal select]	18	0 ~ 18	12	-
	I55	[Multi-function relay select]	18	0 ~ 18	17	-

- Select 0 or 1 in H78 code.
- If H78 code is set to 0 (continuous operation), alarm can be output in I54 or I55.

- ▶ 0: continuous operation when cooling fan trip occurs.
- . Operation is not stopped regardless of cooling fan trip.
- . When I54 or I55 is set to 18 (cooling fan fault alarm), fault alarm signal can be output using Multi-function output terminal or Multi-function relay.

Caution:

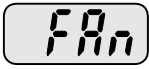
- ▶ If operation is continued after cooling fan trip occurs, Overheat trip may happen and protective function be activated. It also reduces the life of main components due to rise in inverter inner temperature.
- ▶ 1: operation stopped at cooling fan fault
- . When cooling fan fault occurs,  message is displayed on the LED and operation is stopped.
- . If I54 or I55 is set to 17(Fault output), fault message is displayed.

10.17 Parameter read/write

Group	Display	Parameter Name	Setting	Min/Max	Default	Unit
F 2	H91	[Parameter read]	1	0 ~ 1	0	
	H92	[Parameter write]	1	0 ~ 1	0	

- Used to read/write Inverter Parameters using remote keypad.

Caution :
Take caution when Parameter write (H92) is executed. By doing this, parameters in inverter are cleared and parameters in remote keypad are copied to inverter.

▶ Parameter read

Step	Note	Keypad display
1	Move to H91 code.	H91
2	Press Enter (●) key once.	0
3	Press Up (▲) key once.	1
4	Press Enter (●) key twice.	1
5	H91 is displayed when Parameter read is finished.	H91

▶ Parameter write

Step	Note	Keypad display
1	Move to H92 code.	H92
2	Press Enter (●) key once.	0
3	Press Up (▲) key once.	1
4	Press Enter (●) key twice.	1
5	H91 is displayed when Parameter read is finished.	H91

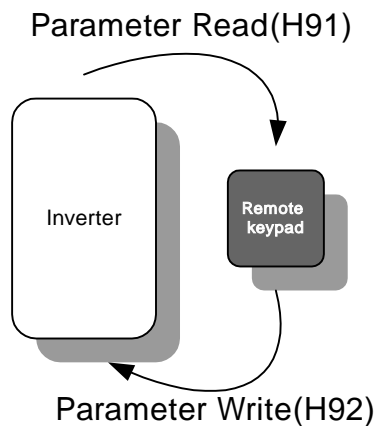

10.18 Parameter Initialize / Lock

- Parameter initialize

Group	Display	Parameter Name	Min/Max		Default
F 2	H93	[Parameter initialize]	0	-	0
			1	4 groups initialize	
			2	Drive group initialize	
			3	F 1 group initialize	
			4	F 2 group initialize	
			5	I/O group initialize	

- Select the group to be initialized and perform it in H93 code.

- ▶ Press Enter (●) key after setting in H93. H93 will be displayed again after initialization is complete.

- Password register

Group	Display	Parameter Name	Setting	Min/Max	Default	Unit
F 2	H94	[Password register]	-	0 ~ FFFF	0	
	H95	[Parameter lock]	-	0 ~ FFFF	0	

- Register password for Parameter lock (H95).
- Password should be Hex decimal. (0 ~ 9, A, B, C, D, E, F)

Caution:
Do not forget the registered password. It is used when unlocking the parameters.

- ▶ Factory default password is 0. Enter the new password except 0.
- ▶ Follow the steps below when you register the password for the first time.

Step	Note	Keypad display
1	Move to H94 code.	H94
2	Press Enter (●) key twice.	0
3	Register password. (Ex: 123)	123
4	123 will blink when Enter (●) key is pressed.	123
5	Press Enter (●) key.	H94

- ▶ Follow the table below to change the password. (Current PW: 123 -> New PW: 456)

Step	Note	Keypad display
1	Move to H94 code.	H94
2	Press Enter (●) key.	0
3	Enter any number (e.g.: 122).	122
4	Press the Enter (●) key. 0 is displayed because wrong value was entered. Password cannot be changed in this status.	0
5	Enter the right password.	123
6	Press Enter (●) key.	123
7	Enter the new password.	456
8	Press the Enter (●) key. Then "456" will blink.	456
9	Press Enter (●) key.	H94

- Parameter Lock

Group	Display	Parameter Name	Setting	Min/Max	Default	Unit
F 2	H95	[Parameter lock]	-	0 ~ FFFF	0	
	H94	[Password register]	-	0 ~ FFFF	0	

- This parameter is used to lock the user-set parameters using the password.

- ▶ See the table below to lock the user-set parameter via the H94 – [Password Register].

Step	Note	Keypad display
1	Move to H95 code.	H94
2	Press Enter (●) key.	UL
3	Parameter value can be changed in UL (Unlock) status.	UL
4	Press Enter (●) key.	0
5	Enter the password created in H94 (e.g.: 123).	123
6	Press Enter (●) key.	L
7	Parameter value cannot be changed in L (Lock) status.	L
8	Press Enter (●) key.	H95

- ▶ See the table below to unlock the user-set parameter via password.

Step	Note	Keypad display
1	Move to H95 code.	H94
2	Press Enter (●) key.	L
3	Parameter value cannot be changed in L(Lock) status.	L
4	Press Enter (●) key.	0
5	Enter the password created in H94 (e.g.: 123).	123
6	Press Enter (●) key.	UL
7	Parameter value can be changed in UL (Unlock) status. While seeing this message...	UL
8	Press Enter (●) key.	H95

Notes:

CHAPTER 11 - MONITORING

11.1 Operating status monitoring

- Output current

Group	Display	Parameter Name	Setting	Min/Max	Default	Unit
Drive	CUr	[Output current]	-			

- Inverter output current can be monitored in Cur.

- Motor RPM

Group	Display	Parameter Name	Setting	Min/Max	Default	Unit
Drive	rPM	[Motor RPM]	-			
F 2	H31	[Number of motor poles]	-	2 ~ 12	4	
	H40	[Control mode select]	-	0 ~ 2	0	
	H74	[Gain for Motor rpm display]	-	1 ~ 1000	100	%

- Motor rpm can be monitored in rPM.

- ▶ When H40 is set to 0 {V/F control} or 1 {PID control}, the Inverter output frequency (f) is displayed in RPM using the formula below. Motor slip is not considered.

$$RPM = \left(\frac{120 \times f}{H31} \right) \times \frac{H74}{100}$$

- ▶ H31: Enter the number of rated motor poles on the nameplate.
- ▶ H74: This parameter is used to change the motor speed display to rotating speed (r/min) or mechanical speed (m/min).

- Inverter DC Link Voltage

Group	Display	Parameter Name	Setting	Min/Max	Default	Unit
Drive	dCL	[Inverter DC Link Voltage]	-			

- Inverter DC link voltage can be monitored in dCL.



- ▶ $\sqrt{2}$ times the value of input voltage is displayed while motor is at a stop.

- User display select

Group	Display	Parameter Name	Setting	Min/Max	Default	Unit
Drive	vOL	[User display select]	-			
F 2	H73	[Monitoring item select]	-	0 ~ 2	0	

- The selected item in H73- [Monitoring item select] can be monitored in vOL- [User display select].
- If output power or torque is selected, Por or tOr will be displayed.

▶ H73: Select one of the desired item numbers.

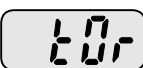
H73	[Monitoring item select]	0	Output voltage [V]	
		1	Output power [kW]	
		2	Torque [kgf · m]	

▶ Enter motor efficiency indicated on motor nameplate to H36 to display correct torque.

- Power on display

Group	Code	Parameter	Setting range	Initial	
F 2	H72	[Power on display]	0	Frequency command (0.00)	0
			1	Accel time (ACC)	
			2	Decel time (DEC)	
			3	Drive mode (drv)	
			4	Frequency mode (Frq)	
			5	Multi-step frequency 1	
			6	Multi-step frequency 2	
			7	Multi-step frequency 3	
			8	Output current (CUr)	
			9	Motor rpm (rPM)	
			10	Inverter DC link voltage (dCL)	
			11	User display select (vOL)	
			12	Fault display 1	
13	Operating direction select				

- Select the parameter to be displayed on the keypad when Power ON.

11.2 Monitoring the I/O terminal

- Input terminal status monitoring

Group	Display	Parameter Name	Setting	Min/Max	Default	Unit
I/O	I25	[Input terminals status display]	-			

- Current input terminal status (ON/Off) can be monitored in I25.

▶ The following is displayed when P1, P3, P4 are ON and P2, P5 are OFF.

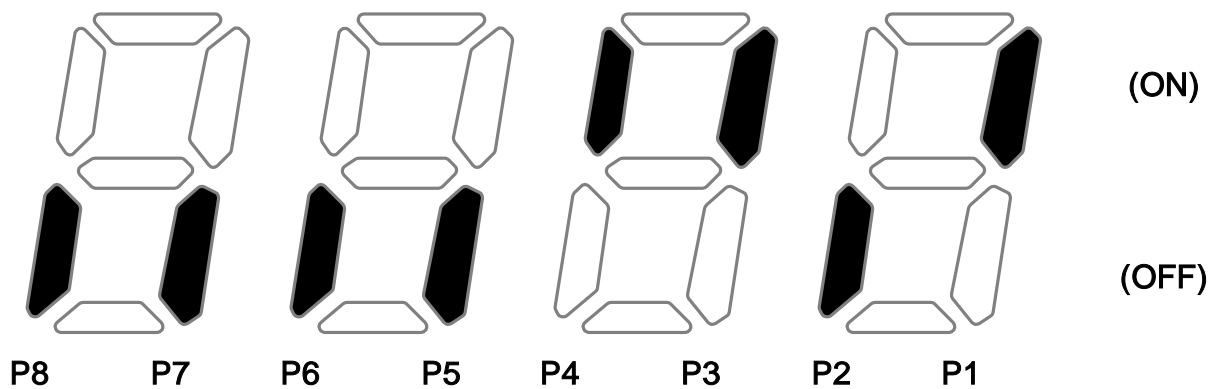

- Output terminal status monitoring

Group	Display	Parameter Name	Setting	Min/Max	Default	Unit
I/O	I26	Output terminals status display	-			

- Current output terminals (MO, relays) status (ON/Off) can be monitored in I26.

▶ The followings are displayed when Multi-function output terminal (MO) is ON with Multi-function relay OFF.

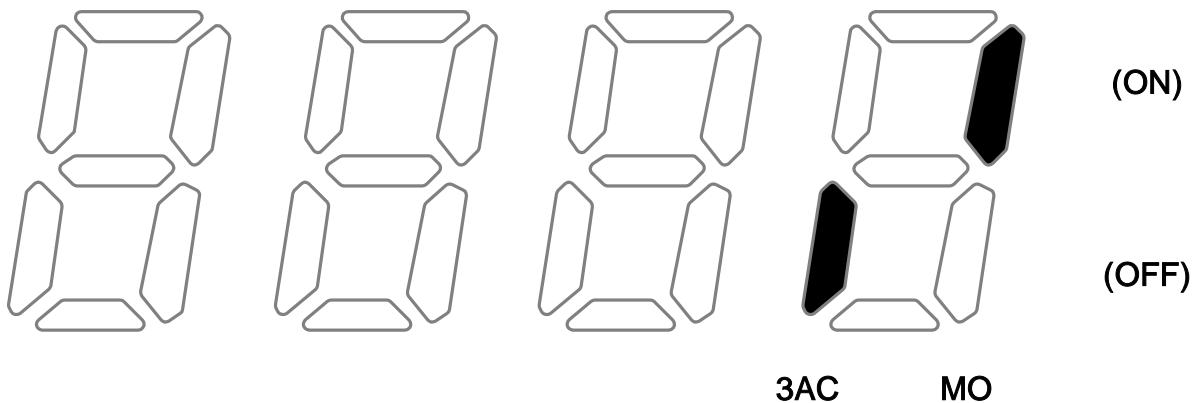





11.3 Monitoring fault condition

- Monitoring current fault status

Group	Display	Parameter Name	Setting	Min/Max	Default	Unit
Drive	nOn	[Current Fault Display]	-			

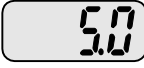
- Fault occurred during operation is displayed in nOn.
- Up to 3 kinds of faults can be monitored.

▶ This parameter gives information on fault types and the operating status at the time of the fault. Refer to Page 5-11 for keypad setting.

Fault types	Frequency		
	Current		
	Accel/Decel Information		Fault during Accel
			Fault during Decel
		Fault during constant run	

▶ Refer to Page 14-1 on fault types.

- Fault History Monitoring

Group	Display	Parameter Name	Setting	Min/Max	Default	Unit
I/O	H 1	[Fault history 1]	-			
	~	~				
	H 5	[Fault history 5]				
	H 6	[Reset fault history]	-	0 ~ 1	0	

- H 1 ~ H 5: Up to 5 faults information is stored.
- H 6: Previous fault information stored in the code H1 thru H5 is all cleared.

▶ When a fault occurs during operation, it can be monitored in the nOn.

- ▶ When the fault condition is reset via the STOP/RST key or multi-function terminal, information displayed in the **nOn** will be moved to H1. In addition, the previous fault info stored in H1 will be automatically moved to H2. Therefore, the updated fault info will be stored in the H1.
- ▶ When more than 1 fault occurred at the same time, up to 3 types of faults will be stored in one code.

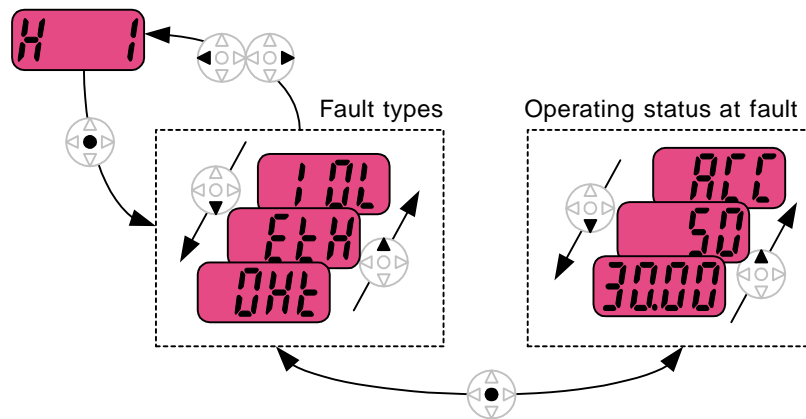

11.4 Analog Output

Group	Display	Parameter Name	Setting	Min/Max	Default	Unit
I/O	I50	[Analog output item select]	-	0 ~ 3	0	
	I51	[Analog output level adjustment]	-	10 ~ 200	100	%

- Output item and the level from the AM terminal are selectable and adjustable.

- I50: The selected item will be output to Analog output terminal (AM).

I50	Analog output item select	Item corresponding to 10V	
		200V	400V
0	Output frequency.	Max Frequency (F21)	
1	Output current	150% of Inverter rated current	
2	Output voltage	282Vac	564Vac
3	Inverter DC link voltage	400Vdc	800Vdc

- I51: If you want to use Analog output value as a gauge input, the value can be adjustable according to various gauge specifications.

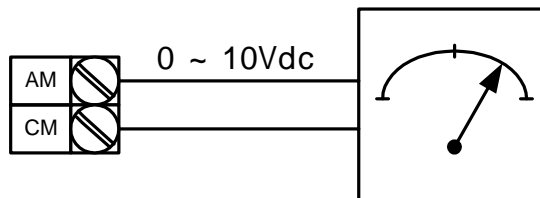

11.5 Multi-function output terminal (MO) and Relay (3AC)

Group	Code	Parameter	Setting range			Initial	
I/O group	I54	[Multi-function output terminal select]	0	FDT-1			12
			1	FDT-2			
	I55	[Multi-function relay select]	2	FDT-3			17
			3	FDT-4			
			4	FDT-5			
			5	Overload {OL}			
			6	Inverter Overload {IOL}			
			7	Motor stall {STALL}			
			8	Over voltage trip {OV}			
			9	Low voltage trip {LV}			
			10	Inverter overheat {OH}			
			11	Command loss			
			12	During run			
			13	During stop			
			14	During constant run			
			15	During speed searching			
			16	Wait time for run signal input			
			17	Fault output			
			18	Cooling fan trip alarm			
		I56	[Fault output] relay		When setting the H26– [Number of auto restart tries]	When the trip other than low voltage trip occurs	
	Bit 2			Bit 1	Bit 0		
0	-			-	-		
1	-			-	✓		
2	-			✓	-		
3	-			✓	✓		
4	✓			-	-		
5	✓			-	✓		
6	✓			✓	-		
7	✓	✓	✓				

- Select the desired item to be output via MO terminal and relay (30AC).

- ▶ I56: When 17 {Fault display} is selected in I54 and I55, Multi-function output terminal and relay will be activated with the value in I56.

- 0: FDT-1

- ▶ Check whether the output frequency matches the user-setting frequency.
- ▶ Active condition: Absolute value (preset frequency - output frequency) \leq Frequency Detection Bandwidth/2

Group	Display	Parameter Name	Setting	Min/Max	Default	Unit
I/O	I53	[Detected Frequency Bandwidth]	-	0 ~ 400	10.00	Hz

- Cannot be set above Max frequency (F21).

- ▶ When setting I53 to 10.0

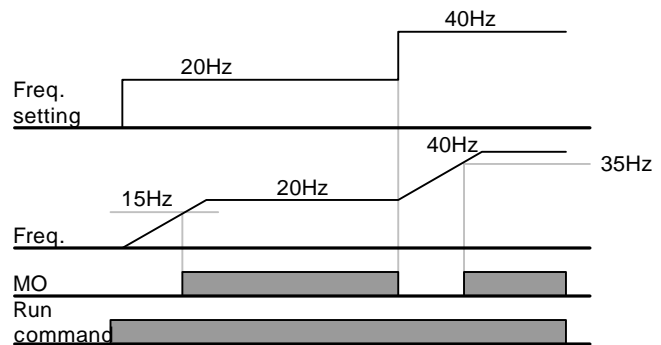

- 1: FDT-2

- ▶ Activated when the preset frequency matches frequency detection level (I52) and FDT-1 condition is met.
- ▶ Active condition: (Preset frequency = FDT level) & FDT-1

Group	Display	Parameter Name	Setting	Min/Max	Default	Unit
I/O	I52	[Detected Frequency level]	-	0 ~ 400	30.00	Hz
	I53	[Detected Frequency Bandwidth]	-		10.00	

- Cannot be set above Max frequency (F21).

- ▶ When setting I52 and I53 to 30.0 Hz and 10.0 Hz, respectively

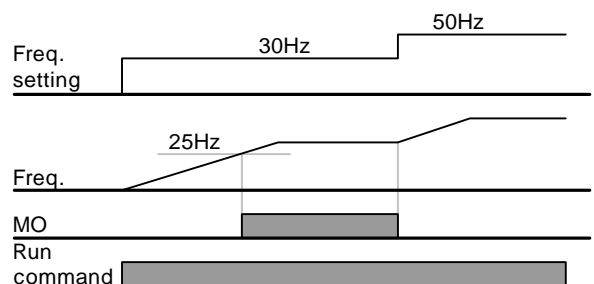

- 2: FDT-3

- ▶ Activated when run frequency meets the following condition.
- ▶ Active condition: Absolute value (FDT level - run frequency) \leq FDT Bandwidth/2

Group	Display	Parameter Name	Setting	Min/Max	Default	Unit
I/O	I52	[Detected Frequency level]	-	0 ~ 400	30.00	Hz
	I53	[Detected Frequency Bandwidth]	-		10.00	

- Cannot be set above Max frequency (F21).

- ▶ When setting I52 and I53 to 30.0Hz and 10.0 Hz, respectively

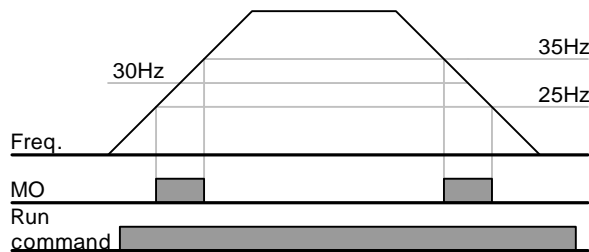

- 3: FDT-4

- ▶ Activated when run frequency meets the following condition.
- Active condition:
 Accel time: Run Frequency \geq FDT Level
 Decel time: Run Frequency $>$ (FDT Level - FDT Bandwidth/2)

Group	Display	Parameter Name	Setting	Min/Max	Default	Unit
I/O	I52	[Detected Frequency level]	-	0 ~ 400	30.00	Hz
	I53	[Detected Frequency Bandwidth]	-		10.00	

- Cannot be set above Max frequency (F21).

- ▶ When setting I52 and I53 to 30.0Hz and 10.0 Hz, respectively

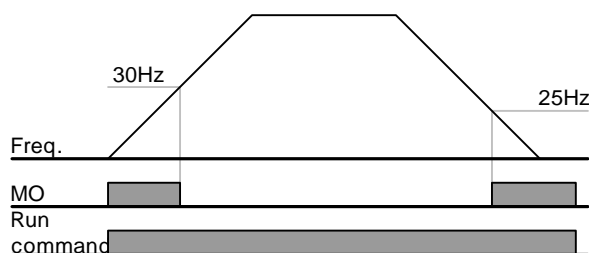

- 4: FDT-5

- ▶ Activated as B contact contrast to FDT-4.

Active condition:

Accel time: Run Frequency \geq FDT Level

Decel time: Run Frequency $>$ (FDT Level – FDT Bandwidth/2)

Group	Display	Parameter Name	Setting	Min/Max	Default	Unit
I/O	I52	[Detected Frequency level]	-	0 ~ 400	30.00	Hz
	I53	[Detected Frequency Bandwidth]	-		10.00	

- Cannot be set above Max frequency (F21).

- ▶ When setting I52 and I53 to 30.0Hz and 10.0 Hz, respectively

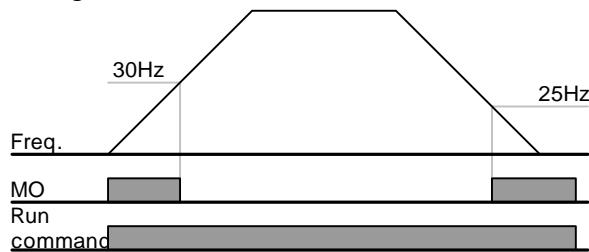

- 5: Overload (OL)

- ▶ Refer to page 12-2.

- 6: Inverter Overload (IOL)

- ▶ Refer to page 12-6.

- 7: Motor stall (STALL)

- ▶ Refer to page 12-3.

- 8: Over voltage trip (Ovt)

- ▶ Activated when over voltage trip occurs due to DC link voltage exceeded 400V.

- 9: Low voltage trip (Lvt)

- ▶ Activated when low voltage trip occurs due to DC link voltage under 400V.

- 10: Inverter heatsink overheat (Oht)

- ▶ Activated when the heatsink is overheated.

- 11: Command loss

- ▶ Activated when Analog (V1,I) and RS485 communication commands are lost.

- 12: During operation
 - ▶ Activated when run command is input and inverter outputs its voltage.

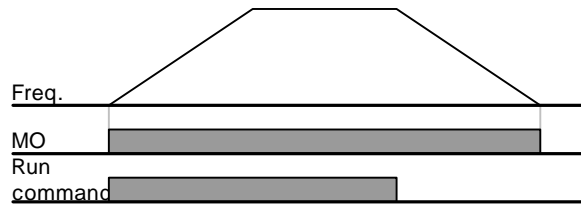

- 13: During stop
 - ▶ Activated during stop without active command.

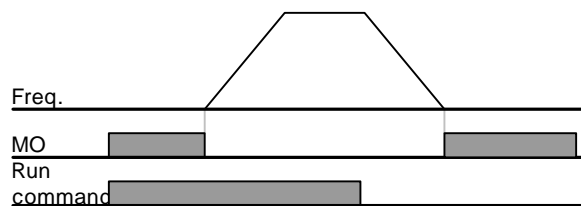

- 14: during constant run
 - ▶ Activated during constant speed operation.

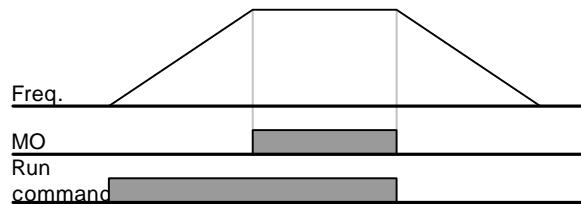

- 15: During speed searching
 - ▶ Refer to page 10-13.
- 16: Wait time for run signal input
 - ▶ This function becomes active during normal operation and that the inverter waits for active run command from external sequence.
- 17: Fault output
 - ▶ The parameter set in I56 is activated.
 - ▶ For example, if setting I55, I56 to 17 and 2, respectively, Multi-function output relay will become active when trip other than “Low voltage trip” occurred.
- 18: Cooling fan trip alarm
 - ▶ Used to output alarm signal when H78 is set to 0(constant operation at cooling fan trip). Refer to page 10-19.

11.6 Output terminal select at keypad-inverter communication error

Group	Display	Parameter Name	Setting	Min/Max	Default	Unit
I/O	I57	[Output terminal select when communication error with keypad]	-	0 ~ 3	0	

- Select relay output or open collector output when keypad-inverter communication fails.

▶ Keypad and inverter CPU communication is made by serial communication, delivering information. When communication error occurs

for a certain time,  will be displayed and error signal can be output to MO or relays.

	MFI output relay	MFI output terminal
	Bit 1	Bit 0
0	-	-
1	-	✓
2	✓	-
3	✓	✓

- ▶ 0: Not used
- ▶ 1: Signal output to MO
- ▶ 2: Signal output to 3A, 3B contacts
- ▶ 3: Signal output to MO, 3A, 3B

CHAPTER 12 - PROTECTIVE FUNCTIONS

12.1 Electronic Thermal

Group	Code	Parameter	Set	Range	Initial	Unit
F 1	F50	[ETH (Electronic thermal) select]	1	0 ~ 1	0	
	F51	[Electronic thermal level for 1 minute]	-	50 ~ 200	150	%
	F52	[Electronic thermal level for continuous]	-		100	%
	F53	[Motor type]	-	0 ~ 1	0	

- Select F50 – [Electronic thermal select] to 1.
- It activates when the motor is overheated (time-inverse). If current greater than set in F51 flows, inverter output is turned off for the preset time in F51- [Electronic thermal level for 1 minute].

- ▶ F51: Enter the value of max current that is capable of flowing to the motor continuously for one minute. It is set in percent of motor rated current. The value cannot be set lower than F52.
- ▶ F52: Enter the amount of current for continuous operation. Normally motor rated current is used. It cannot be set greater than F51.
- ▶ F53: For an inductance motor, cooling effects decrease when a motor is running at low speed. A special motor is a motor that uses a separately powered cooling fan maximize cooling effect even in low speed.

H53	[Motor type]	0	Standard motors having a cooling fan directly connected to the shaft
		1	Special motor that uses a separately powered cooling fan.

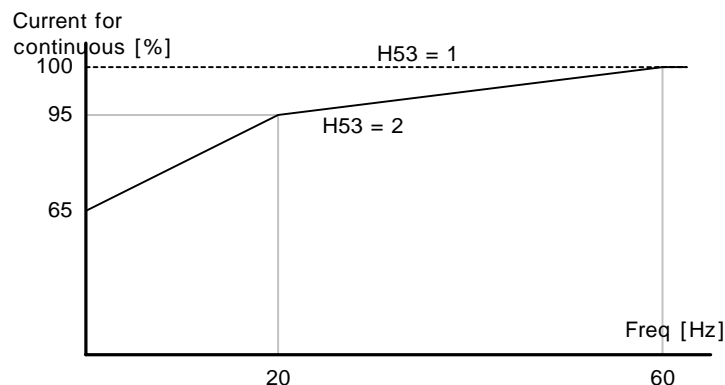

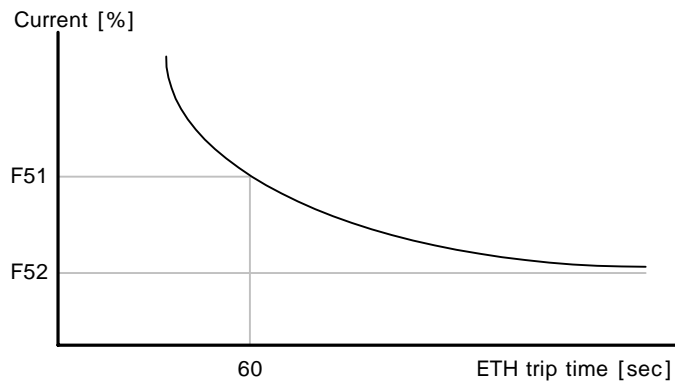

12.2 Overload Warning and trip

- Overload warning

Group	Code	Parameter	Set	Range	Initial	Unit
F 1	F54	[Overload warning level]	-	30 ~ 150	150	%
	F55	[Overload warning time]	-	0 ~ 30	10	Sec
I/O	I54	[Multi-function output terminal select]	5	0 ~ 18	12	
	I55	[Multi-function relay select]	5		17	

- Select one output terminal for this function between MO and 3AC.
- If selecting MO as output terminal, set I54 to 5 {Overload: OL}.

▶ F54: Set the value as a percent of motor rated current.

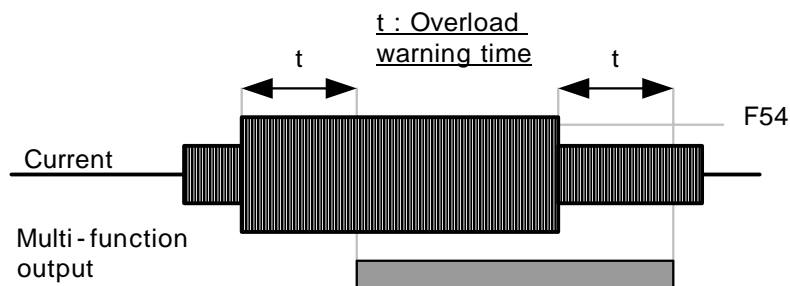

- Overload trip

Group	Code	Parameter	Set	Range	Initial	Unit
F 1	F56	[Overload trip select]	1	0 ~ 1	0	
	F57	[Overload trip level]	-	30 ~ 200	180	%
	F58	[Overload trip time]	-	0 ~ 60	60	

- Set F56 to 1.
- Inverter output is turned off when motor is overloaded.
- Inverter output is turned off when excessive current flows to the motor for F58 – [Overload trip time].

12.3 Stall prevention

Group	Code	Parameter	Set	Range	Initial	Unit
F 1	F59	[Stall prevention select]	-	0 ~ 7	0	
	F60	[Stall prevention level]	-	30 ~ 150	150	%
I/O	I54	[Multi-function output terminal select]	7	0 ~ 18	12	
	I55	[Multi-function relay select]	7		17	

- During acceleration: Motor starts deceleration when current exceeding the value set in F60 flows.
- During constant run: Motor decelerates when current exceeding the value set in F60 flows.
- During deceleration: Motor deceleration is stopped when inverter DC link voltage rises above a certain voltage level.
- F60: The value is set as the percent of motor rated current (H33).
- I54, I55: Inverter outputs signals through multi-function output terminal (MO) or relay output (3AC) when stall prevention function is activated. Stall prevention operation can be monitored by external sequence.

▶ F59: Stall prevention can be set as the table below.

F59	Stall prevention	Setting	During Deceleration	During constant speed	During Acceleration
			Bit 2	Bit 1	Bit 0
		0	-	-	-
1	-	-	✓		
2	-	✓	-		
3	-	✓	✓		
4	✓	-	-		
5	✓	-	✓		
6	✓	✓	-		
7	✓	✓	✓		

- ▶ For example, set F59 to 3 to make stall prevention active during Acceleration and constant run.
- ▶ When stall prevention is executed during acceleration or deceleration, Accel/Decel time may take longer than the user-setting time.
- ▶ When stall prevention is activated during constant run, t1, t2 executed in accordance with the value set in ACC - [Accel time] and dEC - [Decel time].

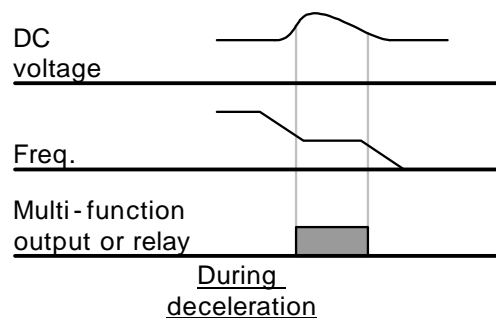
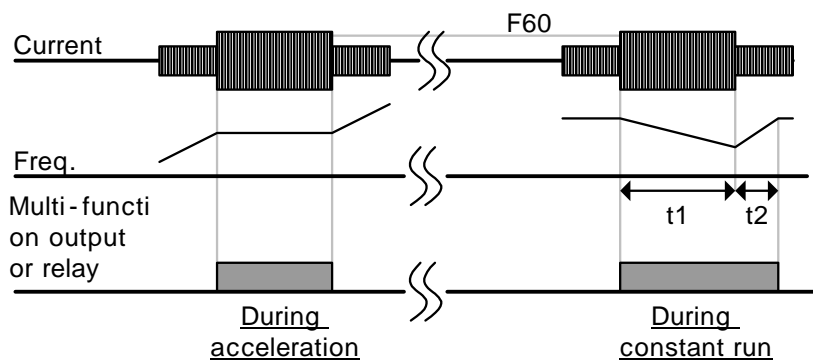

12.4 Output phase loss protection

Group	Code	Parameter	Set	Range	Initial	Unit
F 2	H19	[Input/Output phase loss protection select]	1	0 ~ 3	0	

- Set H19 value to 1.
- Output phase loss: Inverter output is shut off at the event of more than one phase loss among U, V and W.
- Input phase loss: Inverter output is blocked at the event of more than one phase loss among R, S and T. If there is no input phase loss, output is shut off when it is time to replace DC link capacitor.

Caution:

Set H33- [Motor rated current] correctly. If the actual motor rated current and the value of H33 are different, output phase loss protection function could not be activated.

H19	[Input/Output phase loss protection select]	0	Not used
		1	Output phase loss protection
		2	Input phase loss protection
		3	Input/output phase loss protection

12.5 External trip signal

Group	Code	Parameter	Set	Range	Initial	Unit
I/O	I17	[Multi-function input terminal P1 define]		0 ~ 24	0	
	~	~				
	I23	[Multi-function input terminal P7 define]	18		3	
	I24	[Multi-function input terminal P8 define]	19		4	

- Select a terminal among P1 thru P8 to output external trip signal.
- Set I23 and I24 to 18 and 19 to define P7 and P8 as External A contact and B contact.

- ▶ External trip signal input A contact (N.O.): Normal open contact input. When a P7 terminal set to “Ext trip-A” is ON (Closed), inverter displays the fault and turns off its output.
- ▶ External trip signal input B contact (N.C.): Normal close contact input. When a P8 terminal set to “Ext trip-B” is OFF (Open), inverter displays the fault and turns off its output.

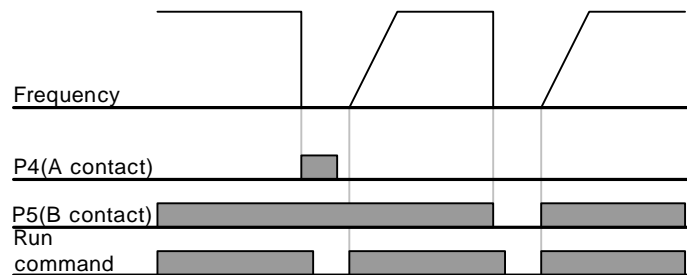
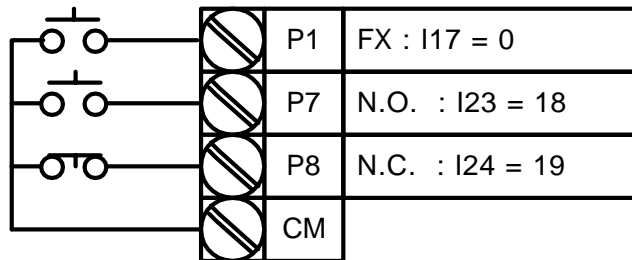

12.6 Inverter Overload

Group	Code	Parameter	Set	Range	Initial	Unit
I/O	I54	[Multi-function output terminal select]	6	0 ~ 18	12	
	I55	[Multi-function relay select]	6		17	

- ▶ Inverter overload prevention function is activated when the current above inverter rated current flows.
- ▶ Multi-function output terminal (MO) or Multi-function relay (3AC) is used as the alarm signal output during inverter overload trip.

12.7 Frequency command loss

Group	Code	Parameter	Set	Range	Initial	Unit
I/O	I16	[Criteria for analog input signal loss]	0	0 ~ 2	0	
	I62	[Drive mode select after loss of frequency command]	-	0 ~ 2	0	
	I63	[Wait time after loss of frequency command]	-	1 ~ 12	1.0	sec
	I54	[Multi-function output terminal select]	11	0 ~ 18	12	
	I55	[Multi-function relay select]	11		17	

- Select the Drive mode when frequency reference set via Analog (V1, I) input terminal or communication option is lost.

▶ I16: This is to set the criteria for analog input signal loss.

I16	[Criteria for analog input signal loss]	0	Disabled (Does not check the analog input signal loss)
		1	When half the value set in I2, I7, I12 is entered
		2	When less than the value set in I2, I7, I12 is entered

Ex 1) The inverter determines the freq reference is lost when DRV- Frq is set to 3 (Analog V1 input), I 16 to 1 and analog input signal is less than half the value set in I 7.

Ex 2) The inverter determines the freq reference is lost when DRV- Frq is set to 6 (V1+I), I 16 to 2 and V1 input signal is either below the value set in I 7 or I input value is less than the I 12 value.

- ▶ I62: When no frequency command is given for the time set in I63, set the drive mode as the table below.

I62	[Drive mode select after loss of frequency command]	0	Continuous operation with the frequency before command loss occurs
		1	Free run stop (output cut off)
		2	Decel to stop

- ▶ I54, I55: Multi-function output terminal (MO) or Multi-function relay output (3AC) is used to output information on loss of frequency command to external sequence.

Ex) when I16 is set to 2, I62 to 2, I63 to 5.0 sec and I54 to 11, respectively,

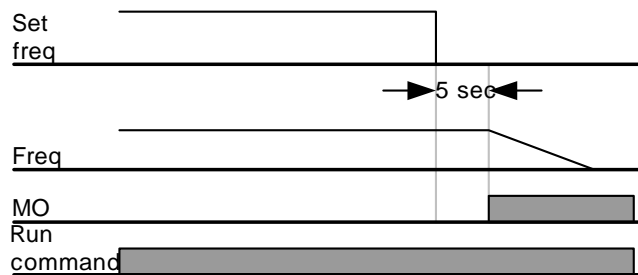

12.8 DB Resistor Enable Duty setting

Group	Code	Parameter	Set	Range	Initial	Unit
F 2	H75	[Enable duty limit]	1	0 ~ 1	1	
	H76	[Enable duty]	-	0 ~ 30	10	%

- Set H75 to 1.
- Set %ED (Enable Duty) in H76.

▶ H75: DB resistor ED limit setting

0	No limit Caution: Take caution when DB resistor is used over its Watt rating. Fire may result from resistor overheat. When resistor having heat detection sensor is used, sensor output can be used as external trip signal in multi-function input.
1	ED is limited as the setting in H 76.

- ▶ H76: set the resistor operating rate(%ED) in one sequence of operation. Continuous usage reate is Max 15 sec and usage signal is not issued over 15 sec.

$$\text{Ex 1) } H76 = \frac{T_{dec}}{T_{acc} + T_{steady} + T_{dec} + T_{stop}} \times 100[\%]$$

Where,

T_{acc}: Acceleration time to reach a setting freq.

T_{steady}: Time for constant speed operation at setting freq.

T_{dec}: Time to decelerate to lower freq. than that in constant speed or time to stop from freq. in constant speed.

T_{stop}: waiting time at a stop before operation is resumed.

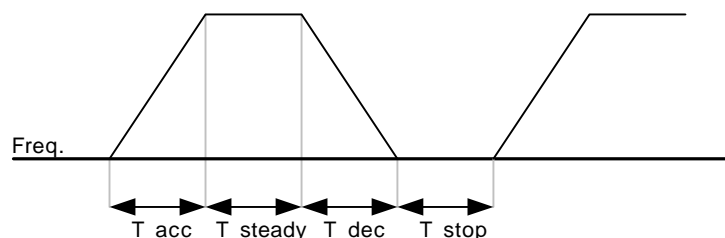

Ex 2)
$$H76 = \frac{T_{dec}}{T_{dec} + T_{steady1} + T_{acc} + T_{steady2}} \times 100[\%]$$

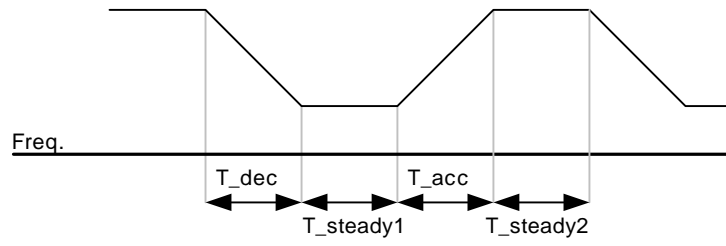

CHAPTER 13 - RS485 COMMUNICATION

13.1 Introduction

Inverter can be controlled and monitored by the sequence program of the PLC or other master module.

Drives or other slave devices may be connected in a multi-drop fashion on the RS-485 network and may be monitored or controlled by a single PLC or PC. Parameter setting and change are available through PC.

13.1.1 Features

Inverter can be easily applied for factory automation because operation and monitoring is available by User-program.

- * Parameter change and monitoring is available via computer.

 - (Ex: Accel/Decel time, Freq. Command etc.)

- * Interface type of RS485 reference:

 - 1) Allows the drive to communicate with any other computers.

 - 2) Allows connection of up to 31 drives with multi-drop link system.

 - 3) Noise-resistant interface.

Users can use any kind of RS232-485 converters. The specifications of converters depend on the manufacturers. Refer to the converter manual for detailed specifications.

13.1.2 Before installation

Before installation and operation, this should be read thoroughly. If not, it can cause personal injury or damage to other equipment.

13.2 Specification

13.2.1 Performance specification

Item	Specification
Communication method	RS485
Transmission form	Bus method, Multi drop Link System
Applicable inverter	SV-iG5A series
Converter	RS232 converter
Connectable drives	Max 31
Transmission distance	Max. 1,200m (Within 700m Recommend)

13.2.2 Hardware specification

Item	Specification
Installation	Use S+, S- terminals on control terminal block
Power supply	Use Insulated power from the inverter power supply

13.2.3 Communication specification

Item	Specification
Communication speed	19,200/9,600/4,800/2,400/1,200 bps selectable
Control procedure	Asynchronous communication system
Communication system	Half duplex system
Character system	ASCII (8 bit)
Stop bit length	Modbus-RTU: 2 bit LG Bus: 1 bit
Sum check	2 byte
Parity check	None

13.3 Installation

13.3.1 Connecting the communication line

Connect the RS485 communication line to the inverter's (S+), (S-) terminals of the control terminals. Check the connection and turn ON the inverter.

If the communication line is connected correctly set the communication-related parameters as the following:

- ▶ DRV-03 [Drive mode]: 3(RS485)
- ▶ DRV-04 [Freq. mode]: 7(RS485)
- ▶ I/O-60 [Inv. Number]: 1~32 (If more than 1 inverters are connected, be sure to use different numbers for each inverter)
- ▶ I/O-61 [Baud-rate]: 3 (9,600 bps as Factory default)
- ▶ I/O-62 [Lost Mode]: 0 - No action (Factory default)
- ▶ I/O-63 [Time-Out]: 1.0 sec (Factory default)
- ▶ I/O-59 [Comm. Prot]: 0 - Modbus-RTU, 1 – LG BUS

13.3.2 Computer and inverter connection

System configuration

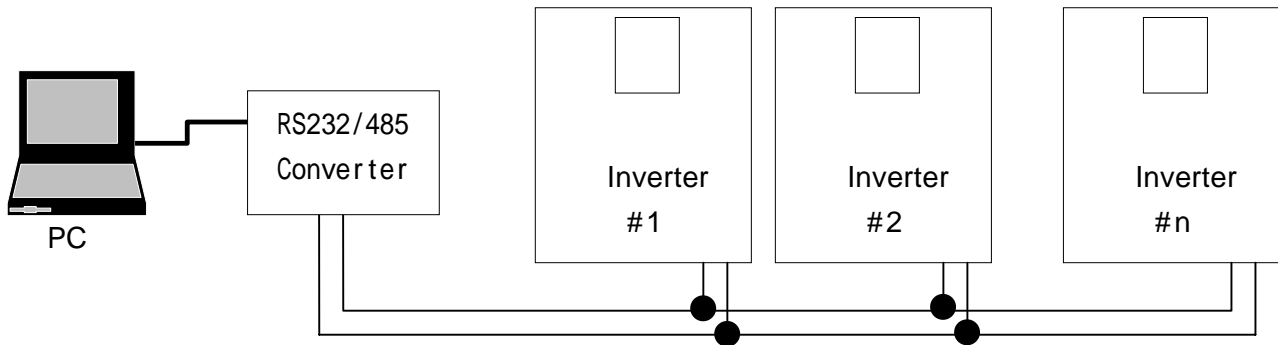

- The number of drives to be connected is up to 31 drives.
- The specification of length of communication line is max. 1200m. To ensure stable communication, limit the length below 700m.
- Make sure JP1 located on the PWB over S+, S- terminal is to be shorted.

13.4 Operation

13.4.1 Operating steps

- Check whether the computer and the inverter are connected correctly.
- Turn ON the inverter. But do not connect the load until stable communication between the computer and the inverter is verified.
- Start the operating program for the inverter from the computer.
- Operate the inverter using the operating program for the inverter.
- Refer to “13.8 Troubleshooting” if the communication is not operating normally.

*User program or the “DriveView” program supplied from LG Industrial Systems can be used as the operating program for the inverter.

13.5 Communication protocol (MODBUS-RTU)

Use Modbus-RTU protocol (Open protocol).

Computer or other hosts can be Master and inverters Slave. Inverter responds to Read/Write command from Master.

Supported function code

Function code	Description
0x03	Read Hold Register
0x04	Read Input Register
0x06	Preset Single Register
0x10	Preset Multiple Register

Exception code

Function code	Description
0x01	ILLEGAL FUNCTION
0x02	ILLEGAL DATA ADDRESS
0x03	ILLEGAL DATA VALUE
0x06	SLAVE DEVICE BUSY
User define	0x14
	1. Write Disable (Address 0x0004 value is 0). 2. Read Only or Not Program during Running.

13.6 Communication protocol (LG BUS)

13.6.1 Basic format

Command message (Request):

ENQ	Drive No.	CMD	Data	SUM	EOT
1 byte	2 bytes	1 byte	n bytes	2 bytes	1 byte

Normal response (Acknowledge Response):

ACK	Drive No.	CMD	Data	SUM	EOT
1 byte	2 bytes	1 byte	n * 4 bytes	2 bytes	1 byte

Negative response (Negative Acknowledge Response):

NAK	Drive No.	CMD	Error code	SUM	EOT
1 byte	2 bytes	1 byte	2 bytes	2 bytes	1 byte

Description:

Request starts with "ENQ" and ends with "EOT".

Acknowledge Response starts with "ACK" and ends with "EOT".

Negative Acknowledge Response starts with "NAK" and ends with "EOT".

"Drive Number" is the number of drives and indicated in 2 bite ASCII-HEX.

(ASCII-HEX: Hexadecimal consists of '0' ~ '9', 'A' ~ 'F')

CMD: Capital letter

Character	ASCII-HEX	Command
'R'	52h	Read
'W'	57h	Write
'X'	58h	Request for monitoring
'Y'	59h	Action for monitoring

Data: ASCII-HEX

Ex) when data value is 3000: 3000 (dec) '0' 'B' 'B' '8'h 30h 42h 42h 38h

Error code: ASCII (20h ~ 7Fh)

Receive/Send buffer size: Receive= 39 bite, Send=44 bite

Monitor register buffer: 8 Word

SUM: to check the communication error

SUM= ASCII-HEX format of lower 8 bit of (Drive No. + CMD + DATA)

Ex) Command Message (Request) for reading one address from address "3000"

ENQ	Drive No	CMD	Address	Number of address to read	SUM	EOT
05h	"01"	"R"	"3000"	"1"	"A7"	04h
1 byte	2 bytes	1 byte	4 bytes	1 byte	2 bytes	1 byte

SUM = '0' + '1' + 'R' + '3' + '0' + '0' + '0' + '1'

= 30h + 31h + 52h + 33h + 30h + 30h + 30h + 31h

= 1A7h (Control values such as ENQ/ACK/NAK are excluded.)

13.6.2 Detail communication protocol

1) Request for Read: Request for read successive 'N' numbers of WORD from address "XXXX"

ENQ	Drive No	CMD	Address	Number of address to read	SUM	EOT
05h	"01" ~ "1F"	"R"	"XXXX"	"1" ~ "8" = n	"XX"	04h
1 byte	2 bytes	1 byte	4 bytes	1 byte	2 bytes	1 byte

Total bite = 12

The quotation marks (" ") means character.

1.1) Acknowledge Response:

ACK	Drive No	CMD	Data	SUM	EOT
06h	"01" ~ "1F"	"R"	"XXXX"	"XX"	04h
1 byte	2 bytes	1 byte	N * 4 bytes	2 byte	1 byte

Total bite = 7 + n * 4 = Max 39

1.2) Negative Acknowledge Response:

NAK	Drive No	CMD	Error code	SUM	EOT
15h	"01" ~ "1F"	"R"	"**"	"XX"	04h
1 byte	2 bytes	1 byte	2 bytes	2 bytes	1 byte

Total bite = 9

2) Request for Write:

ENQ	Drive No	CMD	Address	Number of address to read	Data	SUM	EOT
05h	"01"~ "1F"	"W"	"XXXX"	"1" ~ "8" = n	"XXXX..."	"XX"	04h
1 byte	2 bytes	1 byte	4 bytes	1 byte	n * 4 bytes	2 byte	1 byte

Total bite = 12 + n * 4 = Max 44

2.1) Acknowledge response:

ACK	Drive No	CMD	Data	SUM	EOT
06h	"01" ~ "1F"	"W"	"XXXX..."	"XX"	04h
1:byte	2:bytes	1:byte	n * 4 bytes	2 bytes	1 byte

Total bite = 7 + n * 4 = Max 39

Note) When Request for Write and Acknowledge Response is exchanged between PC and Inverter for the first time, previous data is returned. From the second time of transmission, the current data will be returned.

2.2) Negative response:

NAK	Drive No	CMD	Error code	SUM	EOT
15h	"01" ~ "1F"	"W"	"**"	"XX"	04h
1 byte	2 bytes	1 byte	2 bytes	2 bytes	1 byte

Total bite = 9

3) Request for Monitor Register

This is useful when constant parameter monitoring and data updates are required.

Request for Register of 'n' numbers of Address (not consecutive)

ENQ	Drive No	CMD	Number of address to read	Address	SUM	EOT
05h	"01" ~ "1F"	"X"	"1" ~ "8"=n	"XXXX..."	"XX"	04h
1 byte	2 bytes	1 byte	1 byte	n * 4 byte	2 byte	1 byte

Total bite = 8 + n * 4 = Max 40

3.1) Acknowledge Response:

ACK	Drive No	CMD	SUM	EOT
06h	"01" ~ "1F"	"X"	"XX"	04h
1 byte	2 bytes	1 byte	2 bytes	1 byte

Total bite = 7

3.2) Negative Acknowledge Response:

NAK	Drive No	CMD	Error code	SUM	EOT
15h	"01" ~ "1F"	"X"	"**"	"XX"	04h
1 byte	2 bytes	1 byte	2 bytes	2 bytes	1 byte

Total bite = 9

4) Action Request for monitor register: Request for read of address registered by monitor register.

ENQ	Drive No	CMD	SUM	EOT
05h	"01" ~ "1F"	"Y"	"XX"	04h
1 byte	2 bytes	1 byte	2 bytes	1 byte

Total bite = 7

4.1) Acknowledge response:

ACK	Drive No	CMD	Data	SUM	EOT
06h	"01" ~ "1F"	"Y"	"XXXX..."	"XX"	04h
1 byte	2 bytes	1 byte	n * 4 bytes	2 bytes	1 byte

Total bite= 7 + n * 4 = Max 39

4.2) Negative response:

NAK	Drive No	CMD	Error code	SUM	EOT
15h	"01" ~ "1F"	"Y"	"**"	"XX"	04h
1 byte	2 bytes	1 byte	2 bytes	2 bytes	1 byte

Total bite = 9

5) Error code

Error code	Description
"IF"	When master is sending codes other than Function code (R, W, X, Y).
"IA"	When parameter address does not exist
"ID"	When Data value exceeds its permissible range during 'W' (Write).
"WM"	When the specific parameters cannot be written during 'W' (Write). (For example, in the case of Read Only, Write disabled during Run)
"FE"	When frame size of specific function is not correct and Checksum field is wrong.

13.7 Parameter code list <Common area>

<Common area>: Area accessible regardless of inverter models (Note 3)

Address	Parameter	Scale	Unit	R/W	Data value
0x0000	Inverter model			R	0: SV-iS3 1: SV-iG 2: SV-iV 3: SV-iH 4: SV-iS5 5: SV-iV5 7: SV-iG5 8: SV-iC5 9: SV-iP5 A: SV-iG5A
0x0001	Inverter capacity			R	4: 5.5kW 5: 7.5kW
0x0002	Inverter Input Voltage			R	0: 220V 1: 440V
0x0003	S/W Version			R	(Ex) 0x0100: Version 1.0 0x0101: Version 1.1
0x0004	Parameter Lock			R/W	0: Lock (default) 1: Unlock
0x0005	Frequency Reference	0.01	Hz	R/W	Starting freq. ~ Max. freq.
0x0006	Run Command (Note 1)			R/W	BIT 0: Stop (S) BIT 1: Forward run (F) BIT 2: Reverse run (R)
				W	BIT 3: Fault reset (0->1) BIT 4: Emergency stop
				-	BIT 5: Not used
				R	BIT 6~7: Output freq. arrival 0(Terminal), 1 (keypad) 2(Reserved), 3 (communication) BIT 8~12: Freq. command 0 ~ 8: Multi-step speed freq. (0, 2~8) 9 ~ 11: UpDown (Up, Down, UDZero) 12 ~ 16: Analog (V0, V1, I, V0I, V1I) 17: Jog, 18: PID, 19: Communication 20 ~ 31: Reserved
-	BIT 15: Not used				
0x0007	Acceleration Time	0.1	sec	R/W	
0x0008	Deceleration Time	0.1	sec	R/W	
0x0009	Output Current	0.1	A	R	
0x000A	Output Frequency	0.01	Hz	R	
0x000B	Output Voltage	0.1	V	R	

Address	Parameter	Scale	Unit	R/W	Data value
0x000C	DC Link voltage	0.1	V	R	
0x000D	Output power	0.1	kW	R	
0x000E	Inverter status			R	BIT 0: Stop BIT 1: Forward running BIT 2: Reverse running BIT 3: Fault (Trip) BIT 4: Accelerating BIT 5: Decelerating BIT 6: speed arrival BIT 7: DC Braking BIT 8: Stopping Bit 9: not Used BIT10: Brake Open BIT11: Forward run command BIT12: Reverse run command BIT13: REM. R/S BIT14: REM. Freq.
0x000F	Trip information			R	BIT 0: OCT BIT 1: OVT BIT 2: EXT-A BIT 3: EST (BX) BIT 4: COL BIT 5: GFT (Ground Fault) BIT 6: OHT (Inverter overheat)
0x000F					BIT 7: ETH (Motor overheat) BIT 8: OLT (Overload trip) BIT 9: HW-Diag BIT10: EXT-B BIT11: EEP (Parameter Write Error) BIT12: FAN (Lock & Open Error) BIT13: PO (Phase Open) BIT14: IOLT BIT15: LVT
0x0010	Input terminal status			R	BIT 0: P1 BIT 1: P2 BIT 2: P3 BIT 3: P4

Address	Parameter	Scale	Unit	R/W	Data value
0x0010	Input terminal status				BIT 4: P5 BIT 5: P6 BIT 6: P7 BIT 7: P8
0x0011	Output terminal status			R	BIT 0: Not Used BIT 1: Not Used BIT 2: Not Used BIT 3: Not Used BIT 4: MO (Multi-Output with OC) BIT 5: Not Used BIT 6: Not Used BIT 7: 30AC
0x0012	V1	0~3FF		R	Value corresponding to 0V ~ +10V
0x0013	V2	0~3FF		R	Value corresponding to 0V ~ -10V input when Setting FreqMode to 2
0x0014	I	0~3FF		R	Value corresponding to 0 ~ 20mA input
0x0015	RPM			R	
0x001A	Unit display			R	Not Used
0x001B	Pole number			R	Not Used
0x001C	Custom Version			R	Not Used
0x001D	Trip information-B			R	BIT 0: COM (I/O Board Reset) BIT 1~15: Not Used

Note 1) Detail description on Common area address 0x0006

Bit	Value	R/W	Name	Description
0	0x01	R/W	Stop	Stop command via communication (0->1)
1	0x02	R/W	Forward run	Forward run command via communication (0->1)
2	0x04	R/W	Reverse run	Reverse run command via communication (0->1)
3	0x08	W	Fault reset	Fault reset command via communication (0->1)
4	0x10	W	Emergency stop	Emergency stop command via communication (0->1)
5,15		-	Not used	Not Used
6~7		R	Operating command	0(Terminal),1(keypad),2(option),3(Int. 485)
8~14		R	Frequency command	A. When operating command is issued via Terminal, Keypad or Option 0:DRV-00 1:Not used 2:Multi-speed 1 3: Multi-speed 2 4: Multi-speed 3 5: Multi-speed 4 6: Multi-speed 5 7: Multi-speed 6 8: Multi-speed 7 9:Up 10:Down 11:Up/Down Zero 12:V0 13:V1 14:I 15: V0+I 16: V1+I 17: Jog 18: PID 19: Communication 20 ~ 31: Reserved

Note 2) The changed value in Common area affects the current setting but returns to the previous setting when power is cycled or Inverter is reset. However, changing value is immediately reflected in other parameter groups even in the case of Reset or Power On/Off.

Note 3) S/W version of Common area is displayed in 16 bit, while that of parameter area is displayed in 10 bit.

DRV group

Address		Code	Parameter	Initial value	Max.	Min.
16 bit	10 bit					
A100	41216	D00	Cmd. freq	0	maxFreq	0
A101	41217	D01	ACC	50	60000	0
A102	41218	D02	DEC	100	60000	0
A103	41219	D03	DRV	1	3	0
A104	41220	D04	FRQ	0	8	0
A105	41221	D05	ST 1	1000	maxFreq	0
A106	41222	D06	ST 2	2000	maxFreq	0
A107	41223	D07	ST 3	3000	maxFreq	0
A108	41224	D08	CUR	0	1	0
A109	41225	D09	RPM	0	1800	0
A10A	41226	D10	DCL	0	65535	0
A10B	41227	D11	USR	0	1	0
A10C	41228	D12	FLT	0	1	0
A10D	41229	D13	DRC	0	1	0
A10E	41230	D14	DRV2	1	2	0
A10F	41231	D15	FRQ2	0	6	0

F group

Address		Code	Parameter	Initial value	Max.	Min.
16 bit	10 bit					
A201	41473	F1	Run Prohibit	0	2	0
A202	41474	F2	ACC Pattern	0	1	0
A203	41475	F3	DEC Pattern	0	1	0
A204	41476	F4	Stop Method	0	2	0
A208	41480	F8	DcBr freq	500	6000	startFreq
A209	41481	F9	DcBlk time	10	6000	0
A20A	41482	F10	DcBr value	50	200	0
A20B	41483	F11	DcBr time	10	600	0

Address		Code	Parameter	Initial value	Max.	Min.
16 bit	10 bit					
A20C	41484	F12	DcSt value	50	200	0
A20D	41485	F13	DcSt time	0	600	0
A20E	41486	F14	PreExTime	10	600	0
A214	41492	F20	Jog Freq	1000	maxFreq	0
A215	41493	F21	Max Freq	6000	Freq. High Limit	4000
A216	41494	F22	Base Freq	6000	Freq. High Limit	3000
A217	41495	F23	Start Freq	50	1000	0
A218	41496	F24	Freq Limit	0	1	0
A219	41497	F25	High Freq	6000	maxFreq	0
A21A	41498	F26	Low Freq	50	highFreq	startFreq
A21B	41499	F27	Trq Boost	0	1	0
A21C	41500	F28	Fwd Boost	20	150	0
A21D	41501	F29	Rev Boost	20	150	0
A21E	41502	F30	VF Pattern	0	2	0
A21F	41503	F31	User Freq1	1500	maxFreq	0
A220	41504	F32	User Volt 1	25	100	0
A221	41505	F33	User Freq 2	3000	maxFreq	0
A222	41506	F34	User Volt 2	50	100	0
A223	41507	F35	User Freq 3	4500	maxFreq	0
A224	41508	F36	User Volt 3	75	100	0
A225	41509	F37	User Freq 4	6000	maxFreq	0
A226	41510	F38	User Volt 4	100	100	0
A227	41511	F39	Volt Perc	1000	1100	400
A228	41512	F40	Energy save	0	30	0
A232	41522	F50	ETH select	0	1	0
A233	41523	F51	ETH 1min	150	200	F52
A234	41524	F52	ETH cont	100	F51	50
A235	41525	F53	Motor type	0	1	0
A236	41526	F54	OL level	150	150	30
A237	41527	F55	OL time	100	300	0
A238	41528	F56	OLT select	1	1	0
A239	41529	F57	OLT level	180	200	30
A23A	41530	F58	OLT time	600	600	0
A23B	41531	F59	Stall prev.	0	7	0
A23C	41532	F60	Stall level	150	150	30

H group

Address		Code	Parameter	Initial value	Max.	Min.
16 bit	10 bit					
A300	41728	H0	JUMP CODE	1	100	0
A301	41729	H1	Last Fault1	0	1	0
A302	41730	H2	Last Fault2	0	1	0
A303	41731	H3	Last Fault3	0	1	0
A304	41732	H4	Last Fault4	0	1	0
A305	41733	H5	Last Fault5	0	1	0
A306	41734	H6	Fault Clear	0	1	0
A307	41735	H7	Dwell freq	500	maxFreq	startFreq
A308	41736	H8	Dwell time	0	100	0
A30A	41738	H10	Jump freq	0	1	0
A30B	41739	H11	jump lo 1	1000	JumpHiFreq[0]	startFreq
A30C	41740	H12	jump Hi 1	1500	MaxFreq	JumpLoFreq[0]
A30D	41741	H13	jump lo 2	2000	JumpHiFreq[1]	StartFreq
A30E	41742	H14	jump Hi 2	2500	MaxFreq	JumpLoFreq[1]
A30F	41743	H15	jump lo 3	3000	JumpHiFreq[2]	StartFreq
A310	41744	H16	jump Hi 3	3500	MaxFreq	JumpLoFreq[2]
A311	41745	H17	Curve Time	40	100	1
A312	41746	H18	Curve Time1	40	100	1
A313	41747	H19	Trip select	0	3	0
A314	41748	H20	Power-on run	0	1	0
A315	41749	H21	RST restart	0	1	0
A316	41750	H22	Speed Search	0	15	0
A317	41751	H23	SS Sup-Curr	100	200	80
A318	41752	H24	SS P-gain	100	9999	0
A319	41753	H25	SS I-gain	1000	9999	0
A31A	41754	H26	Retry number	0	10	0
A31B	41755	H27	Retry delay	10	600	0
A31E	41758	H30	Motor select	7	7	0
A31F	41759	H31	Pole number	4	12	2
A320	41760	H32	Rated-Slip	233	1000	0
A321	41761	H33	Rated-Curr	263	500	10
A322	41762	H34	Noload-Curr	110	200	1
A324	41764	H36	Efficiency	87	100	50
A325	41765	H37	Inertia rate	0	2	0
A327	41767	H39	Carrier freq	30	150	10

Address		Code	Parameter	Initial value	Max.	Min.
16 bit	10 bit					
A328	41768	H40	Control Mode	0	3	0
A329	41769	H41	Auto Tune	0	1	0
A32A	41770	H42	Rs	2500	14000	0
A32C	41772	H44	Lsigma	2600	30000	0
A32D	41773	H45	SL P-Gain	1000	32767	0
A32E	41774	H46	SL I-Gain	100	32767	0
A332	41778	H50	PID F/B	0	1	0
A333	41779	H51	PID P-gain	3000	9999	0
A334	41780	H52	PID I-time	100	3200	10
A335	41781	H53	PID D-time	0	3000	0
A336	41782	H54	PID F-gain	0	9999	0
A337	41783	H55	PID limit	6000	maxFreq	startFreq
A346	41798	H70	Acc/Dec freq	0	1	0
A347	41799	H71	Xcel T Mode	1	2	0
A348	41800	H72	PowerOn disp	0	13	0
A349	41801	H73	User disp	0	2	0
A34A	41802	H74	RPM factor	100	1000	1
A34B	41803	H75	DB mode	1	1	0
A34C	41804	H76	DB %ED	10	30	0
A34D	41805	H77	FAN Control	0	1	0
A34E	41806	H78	FAN Trip	0	1	0
A34F	41807	H79	S/W Version	See product manual	100	0
A351	41809	H81	2nd Acc time	50	60000	0
A352	41810	H82	2nd Dec time	100	60000	0
A353	41811	H83	2nd BaseFreq	6000	maxFreq	3000
A354	41812	H84	2nd V/F	0	2	0
A355	41813	H85	2nd F-boost	50	150	0
A356	41814	H86	2nd R-boost	50	150	0
A357	41815	H87	2nd Stall	150	150	30
A358	41816	H88	2nd ETH 1min	150	200	H89
A359	41817	H89	2nd ETH cont	100	H88	50
A35A	41818	H90	2nd R-Curr	263	500	10
A35B	41819	H91	Para Read	0	1	0
A35C	41820	H92	Para Write	0	1	0
A35D	41821	H93	Para Init	0	5	0
A35E	41822	H94	Password set	0	65535	0
A35F	41823	H95	Para. Lock	0	65535	0

I group

Address		Code	Parameter	Initial value	Max.	Min.
16 bit	10 bit					
A401	41985	I1	VR filter	10	9999	0
A402	41986	I2	VR volt x1	0	ViXmax[0]	0
A403	41987	I3	VR freq y1	0	MaxFreq	0
A404	41988	I4	VR volt x2	1000	1000	ViXmin[0]
A405	41989	I5	VR freq y2	6000	MaxFreq	0
A406	41990	I6	V1 filter	10	9999	0
A407	41991	I7	V1 volt x1	0	ViXmax[1]	0
A408	41992	I8	V1 freq y1	0	MaxFreq	0
A409	41993	I9	V1 volt x2	1000	1000	ViXmin[1]
A40A	41994	I10	V1 freq y2	6000	MaxFreq	0
A40B	41995	I11	I filter	10	9999	0
A40C	41996	I12	I curr x1	400	ViXmax[2]	0
A40D	41997	I13	I freq y1	0	MaxFreq	0
A40E	41998	I14	I curr x2	2000	2000	ViXmin[2]
A40F	41999	I15	I freq y2	6000	MaxFreq	0
A410	42000	I16	Wire broken	0	2	0
A411	42001	I17	P1 define	0	24	0
A412	42002	I18	P2 define	1	24	0
A413	42003	I19	P3 define	2	24	0
A414	42004	I20	P4 define	3	24	0
A415	42005	I21	P5 define	4	24	0
A416	42006	I22	P6 define	5	24	0
A417	42007	I23	P7 define	6	24	0
A418	42008	I24	P8 define	7	24	0
A419	42009	I25	In status	0	255	0
A41A	42010	I26	Out status	0	3	0
A41B	42011	I27	Ti Filt Num	15	50	2
A41E	42014	I30	ST 4	3000	MaxFreq	0
A41F	42015	I31	ST 5	2500	MaxFreq	0
A420	42016	I32	ST 6	2000	MaxFreq	0
A421	42017	I33	ST 7	1500	MaxFreq	0
A422	42018	I34	Acc Time-1	30	60000	0
A423	42019	I35	Dec Time-1	30	60000	0
A424	42020	I36	Acc Time-2	40	60000	0
A425	42021	I37	Dec Time-2	40	60000	0

Address		Code	Parameter	Initial value	Max.	Min.
16 bit	10 bit					
A426	42022	I38	Acc Time-3	50	60000	0
A427	42023	I39	Dec Time-3	50	60000	0
A428	42024	I40	Acc Time-4	60	60000	0
A429	42025	I41	Dec Time-4	60	60000	0
A42A	42026	I42	Acc Time-5	70	60000	0
A42B	42027	I43	Dec Time-5	70	60000	0
A42C	42028	I44	Acc Time-6	80	60000	0
A42D	42029	I45	Dec Time-6	80	60000	0
A42E	42030	I46	Acc Time-7	90	60000	0
A42F	42031	I47	Dec Time-7	90	60000	0
A432	42034	I50	FM mode	0	3	0
A433	42035	I51	FM adjust	100	200	10
A434	42036	I52	FDT freq	3000	MaxFreq	0
A435	42037	I53	FDT band	1000	MaxFreq	0
A436	42038	I54	Aux mode 1	12	18	0
A437	42039	I55	Aux mode 2	17	18	0
A438	42040	I56	Relay mode	2	7	0
A439	42041	I57	CommErrMode	0	3	0
A43B	42043	I59	Protocol	0	1	0
A43C	42044	I60	Inv No.	1	32	1
A43D	42045	I61	Baud rate	3	4	0
A43E	42046	I62	Lost command	0	2	0
A43F	42047	I63	Time out	10	120	1

13.8 Troubleshooting

Refer to Troubleshooting when RS 485 communication error occurs.

Check points	Corrective measures
Is the power provided to the converter?	Provide electric power to the converter.
Are the connections between converter and computer correct?	Refer to converter manual.
Is Master not polling?	Verify the master is polling the inverter.
Is baud rate of computer and inverter correctly set?	Set the correct value in accordance with "13.3 Installation".
Is the data format of user program* right?	Revise User Program (Note 1).
Is the connection between converter and communication card right?	Check for GF the correct wiring in accordance with "13.3 Installation".

(Note 1) User program is User-made S/W for PC.

13.9 Miscellaneous

ASCII Code List

Character	Hex	Character	Hex	Character	Hex	Character	Hex	Character	Hex
A	41	a	61	0	30	:	3A	DLE	10
B	42	b	62	1	31	;	3B	EM	19
C	43	c	63	2	32	<	3C	ACK	06
D	44	d	64	3	33	=	3D	ENQ	05
E	45	e	65	4	34	>	3E	EOT	04
F	46	f	66	5	35	?	3F	ESC	1B
G	47	g	67	6	36	@	40	ETB	17
H	48	h	68	7	37	[5B	ETX	03
I	49	i	69	8	38	\	5C	FF	0C
J	4A	J	6A	9	39]	5D	FS	1C
K	4B	k	6B	space	20		5E	GS	1D
L	4C	l	6C	!	21		5F	HT	09
M	4D	m	6D	"	22		60	LF	0A
N	4E	n	6E	#	23	{	7B	NAK	15
O	4F	o	6F	\$	24		7C	NUL	00
P	50	p	70	%	25	}	7D	RS	1E
Q	51	q	71	&	26	~	7E	S1	0F
R	52	r	72	'	27	BEL	07	SO	0E
S	53	s	73	(28	BS	08	SOH	01
T	54	t	74)	29	CAN	18	STX	02
U	55	u	75	*	2A	CR	0D	SUB	1A
V	56	v	76	+	2B	DC1	11	SYN	16
W	57	w	77	,	2C	DC2	12	US	1F
X	58	x	78	-	2D	DC3	13	VT	0B
Y	59	y	79	.	2E	DC4	14		
Z	5A	z	7A	/	2F	DEL	7F		

Notes:

CHAPTER 14 - TROUBLESHOOTING & MAINTENANCE

14.1 Protective functions.







WARNING

When a fault occurs, the cause must be corrected before the fault can be cleared. If protective function keeps active, it could lead to reduction in product life and damage to the equipment.



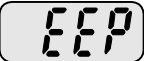
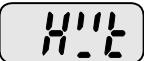
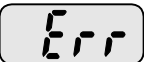

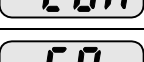
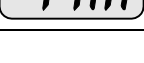

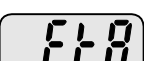
- Fault Display and information

Keypad display	Protective functions	Descriptions
	Overcurrent	The inverter turns off its output when the output current of the inverter flows more than 200% of the inverter rated current.
	Ground fault current	The inverter turns off its output when a ground fault occurs and the ground fault current is more than the internal setting value of the inverter.
	Inverter Overload	The inverter turns off its output when the output current of the inverter flows more than the rated level (150% for 1 minute).
	Overload trip	The inverter turns off its output if the output current of the inverter flows at 150% of the inverter rated current for more than the current limit time (1 min).
	Inverter overheat	The inverter turns off its output if the heat sink overheats due to a damaged cooling fan or an alien substance in the cooling fan by detecting the temperature of the heat sink.
	Output Phase loss	The inverter turns off its output when the one or more of the output (U, V, W) phase is open. The inverter detects the output current to check the phase loss of the output.
	Over voltage	The inverter turns off its output if the DC voltage of the main circuit increases higher than 400 V when the motor decelerates. This fault can also occur due to a surge voltage generated at the power supply system.
	Low voltage	The inverter turns off its output if the DC voltage is below 180V because insufficient torque or overheating of the motor can occur when the input voltage of the inverter drops.
	Electronic Thermal	The internal electronic thermal of the inverter determines the overheating of the motor. If the motor is overloaded the inverter turns off the output. The inverter cannot protect the motor when driving a motor having more than 4 poles or multi motors.
	Input phase loss	Inverter output is blocked when one of R, S, T is open or the electrolytic capacitor needs to be replaced.







- Fault Display and information

Keypad display	Protective functions	Descriptions
	Parameter save error	Displayed when user-setting parameters fails to be entered into memory.
	Inverter hardware fault	Displayed when an error occurs in the control circuitry of the inverter.
	Communication Error	Displayed when the inverter cannot communicate with the keypad.
	Remote keypad communication error	Displayed when inverter and remote keypad does not communicate each other. It does not stop Inverter operation.
	Keypad error	Displayed after Inverter resets keypad when keypad error occurs and this status is maintained for a certain time.
	Cooling fan fault	Displayed when a fault condition occurs in the inverter cooling fan.
	Instant cut off	Used for the emergency stop of the inverter. The inverter instantly turns off the output when the EST terminal is turned on. Caution: The inverter starts to regular operation when turning off the EST terminal while FX or RX terminal is ON.
	External fault A contact input	When multi-function input terminal (I20-I24) is set to 19 {External fault signal input: A (Normal Open Contact)}, the inverter turns off the output.
	External fault B contact input	When multi-function input terminal (I20-I24) is set to 19 {External fault signal input: B (Normal Close Contact)}, the inverter turns off the output.
	Operating method when the frequency command is lost	When inverter operation is set via Analog input (0-10V or 0-20mA input) or option (RS485) and no signal is applied, operation is done according to the method set in I62 (Operating method when the frequency reference is lost).

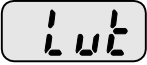
14.2 Fault remedy

Keypad display	Cause	Remedy
 Overcurrent	<p>Caution: When an overcurrent fault occurs, operation must be started after the cause is removed to avoid damage to IGBT inside the inverter.</p> <p>Accel/Decel time is too short compared to the GD^2 of the load. Load is greater than the inverter rating. Inverter output is issued when the motor is free running. Output short circuit or ground fault has occurred. Mechanical brake of the motor is operating too fast.</p>	<ul style="list-style-type: none"> ☞ Increase the Accel/Decel time. ☞ Replace the inverter with appropriate capacity. ☞ Resume operation after stopping the motor or use H22 (Speed search). ☞ Check output wiring. ☞ Check the mechanical brake.
 Ground fault current	<p>Ground fault has occurred at the output wiring of the inverter The insulation of the motor is damaged due to heat.</p>	<ul style="list-style-type: none"> ☞ Check the wiring of the output terminal. ☞ Replace the motor.
 Inverter overload	<p>Load is greater than the inverter rating. Torque boost scale is set too large.</p>	<ul style="list-style-type: none"> ☞ Upgrade the capacity of motor and inverter or reduce the load weight. ☞ Reduce torque boost scale.
 Overload trip		
 Inverter overheat	<p>Cooling system has faults. An old cooling fan is not replaced with a new one. Ambient temperature is too high.</p>	<ul style="list-style-type: none"> ☞ Check for alien substances clogged in the heat sink. ☞ Replace the old cooling fan with a new one. ☞ Keep ambient temperature under 50°C.
 Output Phase loss	<p>Faulty contact of magnetic switch at output Faulty output wiring</p>	<ul style="list-style-type: none"> ☞ Make connection of magnetic switch at output of the inverter securely. ☞ Check output wiring.
 Cooling fan fault	<p>An alien substance is clogged in a ventilating slot. Inverter has been in use without changing a cooling fan.</p>	<ul style="list-style-type: none"> ☞ Check the ventilating slot and remove the clogged substances. ☞ Replace the cooling fan.

Fault remedy

Keypad display	Cause	Remedy
 Over voltage	Decel time is too short compared to the GD^2 of the load. Regenerative load is at the inverter output. Line voltage is too high.	<ul style="list-style-type: none"> ☞ Increase the Decel time. ☞ Use Dynamic Brake Unit. ☞ Check whether line voltage exceeds its rating.
 Low voltage	Line voltage is low. Load larger than line capacity is connected to line (ex: welding machine, motor with high starting current connected to the commercial line). Faulty magnetic switch at the input side of the inverter.	<ul style="list-style-type: none"> ☞ Check whether line voltage is below its rating. ☞ Check the incoming AC line. Adjust the line capacity corresponding to the load. ☞ Change a magnetic switch.
 Electronic thermal	Motor has overheated. Load is greater than inverter rating. ETH level is set too low. Inverter capacity is incorrectly selected. Inverter has been operated at low speed for too long.	<ul style="list-style-type: none"> ☞ Reduce load weight and operating duty. ☞ Change inverter with higher capacity. ☞ Adjust ETH level to an appropriate level. ☞ Select correct inverter capacity. ☞ Install a cooling fan with a separate power supply.
 External fault A contact input	The terminal set to "18 (External fault-A)" or "19 (External fault-B)" in I20-I24 in I/O group is ON.	<ul style="list-style-type: none"> ☞ Eliminate the cause of fault at circuit connected to external fault terminal or cause of external fault input.
 External fault B contact input		
 Operating method when the frequency command is lost	No frequency command is applied to V1 and I.	<ul style="list-style-type: none"> ☞ Check the wiring of V1 and I and frequency reference level.
 Remote keypad communication error	Communication error between inverter keypad and remote keypad	<ul style="list-style-type: none"> ☞ Check for connection of communication line and connector.

Fault remedy

Protective functions & cause	Descriptions
 <p>EEP : Parameter save error HWT : Hardware fault Err : Communication Error COM : Keypad error</p>	<p>☞ Contact your local LGIS sales representative.</p>

14.3 Precautions for maintenance and inspection

WARNING

Make sure to remove the input power while performing maintenance.
Make sure to perform maintenance after checking the DC link capacitor has discharged. The bus capacitors in the inverter main circuit can still be charged even after the power is turned off. Check the voltage between terminal P or P1 and N using a tester before proceeding.
SV-iG5A series inverter has ESD (Electrostatic Discharge) sensitive components. Take protective measures against ESD before touching them for inspection or installation.
Do not change any inner parts and connectors. Never modify the inverter.

14.4 Check points

■ Daily inspections

Proper installation environment
Cooling system fault
Unusual vibration and noise
Unusual overheating and discoloration

■ Periodic inspection

Screws and bolts may become loose due to vibration, temperature changes, etc.
Check that they are tightened securely and retighten as necessary.
Alien substances are clogged in the cooling system.
Clean it using the air.
Check the rotating condition of the cooling fan, the condition of capacitors and the connections with the magnetic contactor.
Replace them if there are any abnormalities.

14.5 Part replacements

The inverter consists of many electronic parts such as semiconductor devices. The following parts may deteriorate with age because of their structures or physical characteristics, leading to reduced performance or failure of the inverter. For preventive maintenance, the parts must be changed periodically. The parts replacement guidelines are indicated in the following table. Lamps and other short-life parts must also be changed during periodic inspection.

Part name	Change period (unit: Year)	Description
Cooling fan	3	Exchange (as required)
DC link capacitor in main circuit	4	Exchange (as required)
Electrolytic capacitor on control board	4	Exchange (as required)
Relays	-	Exchange (as required)

CHAPTER 15 - SPECIFICATIONS

15.1 Technical data

- Input & output ratings: 200V

SV		iG5A -2	004	008NC	008	015	022	037	040	055	075
Max capacity ¹	[HP]									7.5	10
	[kW]									5.5	7.5
Output ratings	Capacity [kVA] ²									9.1	12.2
	FLA [A] ³									24	32
	Frequency	0 ~ 400 [Hz] ⁴									
	Voltage	3Φ 200 ~ 230V ⁵									
Input ratings	Voltage	3Φ 200 ~ 230 VAC (+10%, -15%)									
	Frequency	50 ~ 60 [Hz] (±5%)									
Cooling method			Natural convection			Forced cooling					
Weight [kg]										3.66	3.66

- Input & output ratings: 400V

SV		iG5A - 4	004	008NC	008	015	022	037	040	055	075
Max capacity	[HP]									7.5	10
	[kW]									5.5	7.5
Output ratings	Capacity [kVA] ²									9.1	12.2
	FLA [A] ³									12	16
	Frequency	0 ~ 400 [Hz] ⁴									
	Voltage	3Φ 380 ~ 460V ⁵									
Input ratings	Voltage	3Φ 380 ~ 460 VAC (+10%, -15%)									
	Frequency	50 ~ 60 [Hz] (±5%)									
Cooling method			Natural convection			Forced cooling					
Weight [kg]										3.66	3.66

1) Indicates the maximum applicable motor capacity when using a 4-pole LG Standard motor.

2) Rated capacity is based on 220V for 200V class and 440V for 400V class.

3) Refer to 15-3 when Carrier frequency setting (39) is above 3kHz.

4) Max frequency setting range is extended to 300Hz when H40 (Control mode select) is set to 3 (Sensorless vector control).

5) Maximum output voltage cannot be higher than the input voltage. It can be programmable below input voltage.

● Control

Control method		V/F, Sensorless vector control
Frequency setting resolution		Digital command: 0.01Hz Analog command: 0.06Hz (Max freq.: 60Hz)
Frequency accuracy		Digital command: 0.01% of Max output frequency Analog command: 0.1% of Max output frequency
V/F pattern		Linear, Squared, User V/F
Overload capacity		150% per 1 min.
Torque boost		Manual/Auto torque boost
Dynamic Braking	Max braking torque	20% ¹⁾
	Max Duty	150% ²⁾ when using optional DB resistor

1) Means average braking torque during Decel to stop of a motor.

2) Refer to Chapter 16 for DB resistor specification.

● Operation

Operation mode		Keypad/ Terminal/ Communication option/ Remote keypad selectable	
Frequency setting		Analog: 0 ~ 10[V], -10 ~ 10[V], 0 ~ 20[mA] Digital: Keypad	
Operation features		PID, Up-down, 3-wire	
Input	Multi-function terminal P1 ~ P8	NPN / PNP selectable (See page 3-6)	
		FWD/REV RUN, Emergency stop, Fault reset, Jog operation, Multi-step Frequency-High, Mid, Low, Multi-step Accel/Decel-High, Mid, Low, DC braking at stop, 2 nd motor select, Frequency UP/Down, 3-wire operation, External trip A, B, PID-Inverter (v/f) operation bypass, Option-inverter(v/f) operation bypass, Analog Hold, Accel/Decel stop	
Output	Open collector terminal	Fault output and inverter status output	Less than DC 24V 50mA
	Multi-function relay		(N.O., N.C.) Less than AC250V 1A, Less than DC 30V 1A
	Analog output	0 ~ 10 Vdc (less than 10mA): Freq, Current, Voltage, DC link selectable	

- Protective function

Trip	Over Voltage, Under Voltage, Over Current, Ground Fault current detection, Inverter Overheat, Motor Overheat, Output Phase Open, Overload Protection, Communication Error, Loss of Speed Command, Hardware Fault, Fan trip
Alarm	Stall prevention, overload
Momentary Power Loss	Below 15 msec: Continuous operation (should be within rated input voltage, rated output power.) Above 15 msec: Auto restart enable

- Environment

Protection degree	IP 20, NEMA TYPE 1 (Option)
Ambient temp	-10°C ~ 50°C
Storage temp	-20°C ~ 65°C
Humidity	Below 90% RH (no condensation)
Altitude/Vibration	Below 1,000m, 5.9m/sec ² (0.6G)
Atmospheric pressure	70~106 kPa
Location	Protected from corrosive gas, combustible gas, oil mist or dust

15.2 Temperature Derating Information

- Load current according to Carrier frequency

Changing Carrier freq. at temperature rise (Default)

Using fixed carrier frequency

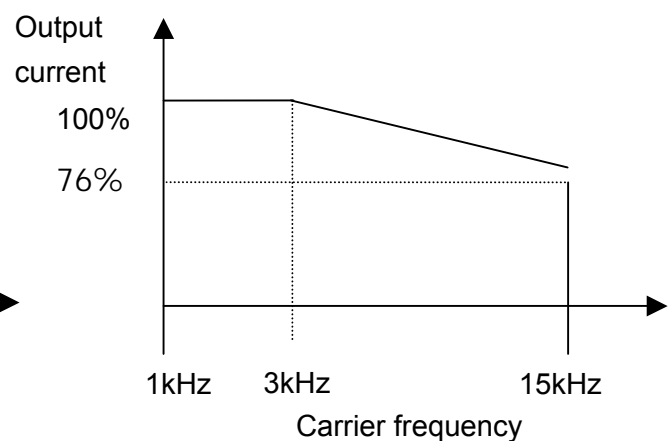
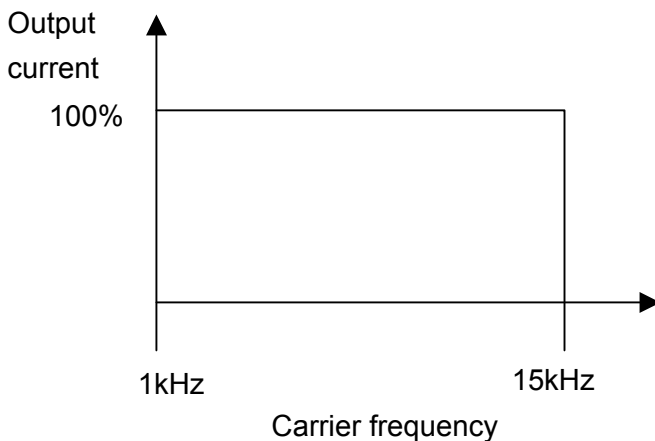

Caution:

- 1) The above graph is applied when inverter is in use within the permissible ambient temp. If the unit is installed in a panel, install it where heat dissipation is properly made to keep the panel ambient temp within permissible range.
- 2) This derating curve is based on inverter rated current when the rated motor for the inverter is connected.

Notes:

CHAPTER 16 - OPTION

16.1 Remote keypad

(Reserved)

16.2 Conduit option

(Reserved)

16.3 EMC filter

(Reserved)

16.4 Braking resistor

Input Voltage	Inverter capacity [kW]	100 % braking		150% braking	
		[Ω]	[W]*	[Ω]	[W]*
200	0.4	400	50	300	100
	0.75	200	100	150	150
	1.5	100	200	60	300
	2.2	60	300	50	400
	3.7	40	500	33	600
	5.5	30	700	20	800
	7.5	20	1000	15	1200
	400	0.4	1800	50	1200
0.75		900	100	600	150
1.5		450	200	300	300
2.2		300	300	200	400
3.7		200	500	130	600
5.5		120	700	85	1000
7.5		90	1000	60	1200

* The wattage listed above is based on Enable duty (%ED) 5% with continuous braking time 15 sec.

CHAPTER 17 - DECLARATION OF CONFORMITY

Council Directive(s) to which conformity is declared:

CD 73/23/EEC and CD 89/336/EEC

Units are certified for compliance with:

**EN 61800-3/A11 (2000)
EN 61000-4-2/A2 (2001)
EN 61000-4-3/A2 (2001)
EN 61000-4-4/A2 (2001)
EN 61000-4-5/A1 (2001)
EN 61000-4-6/A1 (2001)
EN 55011/A2 (2002)
EN 50178 (1997)
IEC/TR 61000-2-1 (1990)
EN 61000-2-2 (2002)**

Type of Equipment: **Inverter (Power Conversion Equipment)**

Model Name: **SV - iG5A Series**

Trade Mark: **LG Industrial Systems Co., Ltd.**

Representative: **LG International (Deutschland) GmbH**
Address: **Lyoner Strasse 15,
Frankfurt am Main, 60528,
Germany**

Manufacturer: **LG Industrial Systems Co., Ltd.**
Address: **181, Samsung-ri, Mokchon-Eup,
Chonan, Chungnam, 330-845,
Korea**

We, the undersigned, hereby declare that equipment specified above conforms to the Directives and Standards mentioned.

Place: **Frankfurt am Main**
Germany

Chonan, Chungnam,
Korea

 20/02/01
(Signature/Date)

Mr. Ik-Seong Yang / Dept. Manager
(Full name / Position)

 2002/11/26
(Signature/Date)

Mr. Jin Goo Song / General Manager
(Full name / Position)

TECHNICAL STANDARDS APPLIED

The standards applied in order to comply with the essential requirements of the Directives 73/23/CEE "Electrical material intended to be used with certain limits of voltage" and 89/336/CEE "Electromagnetic Compatibility" are the following ones:

- **EN 50178 (1997)** “Electronic equipment for use in power installations”.
- **EN 61800-3/A11 (2000)** “Adjustable speed electrical power drive systems. Part 3: EMC product standard including specific methods”
- **EN 55011/A2 (2002)** “Industrial, scientific and medical (ISM) radio-frequency equipment. Radio disturbances characteristics. Limits and methods of measurement”
- **EN 61000-4-2/A2 (2001)** “Electromagnetic compatibility (EMC). Part 4: Testing and measurement techniques. Section 2: Electrostatic discharge immunity test.
- **EN 61000-4-3/A2 (2001)** “Electromagnetic compatibility (EMC). Part 4: Testing and measurement techniques. Section 3: Radiated, radiofrequency, electromagnetic field immunity test.
- **EN 61000-4-4/A2 (2001)** “Electromagnetic compatibility (EMC). Part 4: Testing and measurement techniques. Section 4: Electrical fast transients / burst immunity test.
- **EN 61000-4-5/A1 (2000)** “Electromagnetic compatibility (EMC). Part 4: Testing and measurement techniques. Section 5: Surge immunity test.
- **EN 61000-4-6/A1 (2001)** “Electromagnetic compatibility (EMC). Part 4: Testing and measurement techniques. Section 6: Immunity to conducted disturbances, induced by radio-frequency fields.
- **CEI/TR 61000-2-1 (1990)** “Electromagnetic compatibility (EMC). Part 2: Environment. Environment description for low-frequency conducted disturbances and signaling in public low voltages supply systems”
- **EN 61000-2-2 (2002)** “Electromagnetic compatibility (EMC). Part 2: Environment. Compatibility level for low-frequency conducted disturbances and signaling in public low voltages supply systems”

RFI FILTERS

THE L.G. RANGE OF POWER LINE FILTERS **FF (Footprint) - FE (Standard) SERIES**, HAVE BEEN SPECIFICALLY DESIGNED WITH HIGH FREQUENCY **LG INVERTERS**. THE USE OF L.G. FILTERS, WITH THE INSTALLATION ADVICE OVERLEAF HELP TO ENSURE TROUBLE FREE USE ALONG SIDE SENSITIVE DEVICES AND COMPLIANCE TO CONDUCTED EMISSION AND IMMUNITY STANDARDS TO EN 50081 -> EN61000-6-3:02 and EN61000-6-1:02

CAUTION

IN CASE OF A LEAKAGE CURRENT PROTECTIVE DEVICES IS USED ON POWER SUPPLY, IT MAY BE FAULT AT POWER-ON OR OFF. IN AVOID THIS CASE, THE SENSE CURRENT OF PROTECTIVE DEVICE SHOULD BE LARGER THAN VALUE OF LEAKAGE CURRENT AT WORST CASE IN THE BELOW TABLE.

RECOMMENDED INSTALLATION INSTRUCTIONS

To conform to the EMC directive, it is necessary that these instructions be followed as closely as possible. Follow the usual safety procedures when working with electrical equipment. All electrical connections to the filter, inverter and motor must be made by a qualified electrical technician.

- 1-) Check the filter rating label to ensure that the current, voltage rating and part number are correct.
- 2-) For best results the filter should be fitted as closely as possible to the incoming mains supply of the wiring enclosure, usually directly after the enclosures circuit breaker or supply switch.
- 3-) The back panel of the wiring cabinet of board should be prepared for the mounting dimensions of the filter. Care should be taken to remove any paint etc... from the mounting holes and face area of the panel to ensure the best possible earthing of the filter.
- 4-) Mount the filter securely.
- 5-) Connect the mains supply to the filter terminals marked LINE, connect any earth cables to the earth stud provided. Connect the filter terminals marked LOAD to the mains input of the inverter using short lengths of appropriate gauge cable.
- 6-) Connect the motor and fit the ferrite core (output chokes) as close to the inverter as possible. Armoured or screened cable should be used with the 3 phase conductors only threaded twice through the center of the ferrite core. The earth conductor should be securely earthed at both inverter and motor ends. The screen should be connected to the enclosure body via and earthed cable gland.
- 7-) Connect any control cables as instructed in the inverter instructions manual.

IT IS IMPORTANT THAT ALL LEAD LENGTHS ARE KEPT AS SHORT AS POSSIBLE AND THAT INCOMING MAINS AND OUTGOING MOTOR CABLES ARE KEPT WELL SEPARATED.

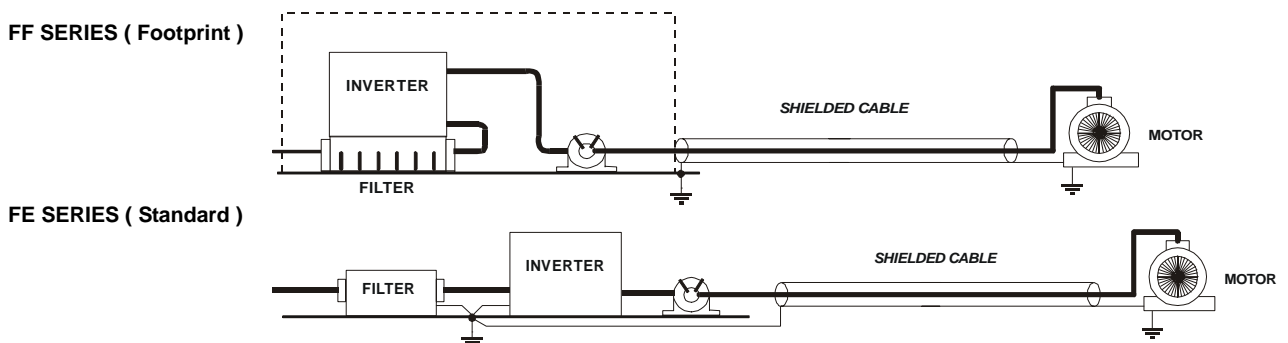

iG5A series / Footprint Filters												
INVERTER	POWER	CODE	CURRENT	VOLTAGE	LEAKAGE CURRENT	DIMENSIONS			MOUNTING	WEIGHT	MOUNT	OUTPUT CHOKES
					NOM.	L	W	H	Y	X		
					MAX.							
THREE PHASE												
SV055iG5A-2	5.5kW	FFG5A-T030-(x)	30A	250VAC	0.5mA 27mA	270x189.5x60			256x150	2 Kg.	M5	FS - 2
SV075iG5A-2	7.5kW	FFG5A-T050-(x)	50A	250VAC	0.5mA 27mA	270x189.5x60			256x150	2.5 Kg.	M5	FS - 2
SV055iG5A-4	5.5kW	FFG5A-T030-(x)	30A	380VAC	0.5mA 27mA	270x189.5x60			256x150	2 Kg.	M5	FS - 2
SV075iG5A-4	7.5kW											

iG5A series / Standard Filters												
INVERTER	POWER	CODE	CURRENT	VOLTAGE	LEAKAGE CURRENT	DIMENSIONS			MOUNTING	WEIGHT	MOUNT	OUTPUT CHOKES
					NOM.	L	W	H	Y	X		
					MAX.							
THREE PHASE												
SV055iG5A-2	5.5kW	FE-T030-(x)	30A	250VAC	0.5mA 27mA	270x140x60			258x106	2.4 Kg.	---	FS - 2
SV075iG5A-2	7.5kW	FE-T050-(x)	50A	250VAC	0.5mA 27mA	270x140x90			258x106	3.2 Kg.	---	FS - 2
SV055iG5A-4	5.5kW	FE-T030-(x)	30A	380VAC	0.5mA 27mA	270x140x60			258x106	2.4 Kg.	---	FS - 2
SV075iG5A-4	7.5kW											

(x) (1) Industrial environment EN50081-2 (A class) -> EN61000-6-4:02

(3) Domestic and industrial environment EN50081-1 (B class) -> EN61000-6-3:02

FF SERIES (Footprint)

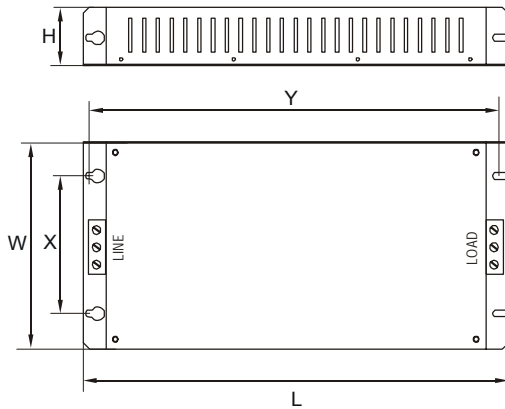

FE SERIES (Standard)

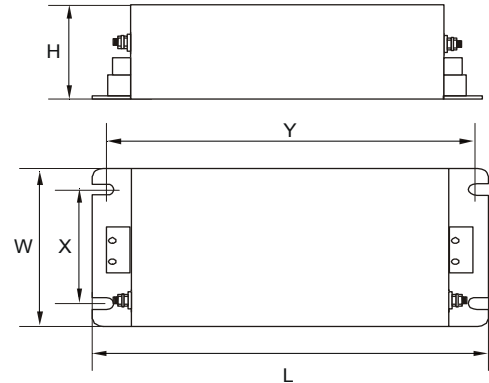

FS SERIES (output chokes)

CODE	D	W	H	X	Ø
FS - 2	28.5	105	62	90	5