

## Chapter 1. GENERAL

### 1.1 Guide to User's Manual

This User's Manual gives the specifications, performance and handling instructions for each of the necessary units of the GLOFA-GM6 series PLC system.

The configuration of the User's Manual is as follows.

No	Title	Content
Chapter 1	General	Describes configuration of this manual, units' features and terminology.
Chapter 2	System Configuration	Describes available units and system configurations in the GLOFA-GM6 series.
Chapter 3	General Specifications	Describes general specifications of units used in the GLOFA-GM6 series.
Chapter 4	CPU Module	Describes the performance, specifications and functions of the CPU module.
Chapter 5	Battery	Describes the specifications and handling instructions for other modules except for the CPU module.
Chapter 6	Using the user program in flash memory	
Chapter 7	Digital Input and output Module	
Chapter 8	Power Supply Module	
Chapter 9	Base Board	
Chapter 10	Installation and Wiring	Describes installation, wiring and handling instructions for reliability of the PLC system.
Chapter 11	Maintenance	Describes the check items and method for long term normal operation of the PLC system.
Chapter 12	Troubleshooting	Describes various operation errors and corrective actions.
Chapter 13 ~ Chapter 16	Built-in special functions of GM6 CPU module	Describes Cnet communication dedicated for GM6 CPU (Ch.13), RS-422 master communication (Ch.14), PID control (Ch.15), and High speed counter (Ch.16).
Appendix 1	System Definitions	Describes parameter setting for basic I/O module and communications module.
Appendix 2	Function/Function Block List	Describes the types and processing time of function/function block.
Appendix 3	Flag List	Describes the types and content of various flags.
Appendix 4	Dimensions	Shows dimensions of the CPU, I/O module and base board.

**REMARK**

1) This manual does not describes the special/communications module and programming for them. For their own functions, refer to the related User's Manual.

## 1.2 Features

1) GLOFA-GM series features:

- (1) Design on the basis of international standard specifications(IEC 1131-3)
  - Easy programming device support.
  - Languages in compliance with IEC1131-3 are given. (IL/ LD / SFC)
- (2) Open network by use of communications protocol in compliance with international standard specifications.
- (3) High speed processing with an operation-dedicated processor included.
- (4) Various special modules that enlarge the range of application of the PLC.

2) GM6-CPUA/B/C features :

- (1) High speed operation processing  
High speed processing of 0.5  $\mu$ s/step with an operation-dedicated processor included.
- (2) Heightened Self-diagnosis  
Cause of errors is easily found as error codes has been more divided in accordance with their contents.
- (3) Restart mode setting  
The User can set Cold / Warm restart mode in accordance with the environment.
- (4) Debug operation  
On-line debugging is available if the PLC operation mode is set to debug operation mode.  
Debugging functions :
  - Executed by one instruction.
  - Executed by the break-point settings
  - Executed by the device status
  - Executed by the specified scan times
- (5) Various Program Executions  
Time driven task, external and internal contact task programs as well as scan program can be executed by setting the execution condition. The user can set variously the program execution mode.
- (6) Various data type

**1.3 Terminology**

The following table gives definition of terms used in this manual.

Terms	Definition	Remarks
Module	A standard element that has a specified function which configures the system. Devices such as I/O board, which inserted onto the mother board or base unit.	Example) CPU module Power Supply module I/O module
PLC system	A system which consists of the PLC and peripheral devices. A user program can control the system.	
Cold Restart	To restart the PLC system and user programs after all of the data(Variables and programs of I/O image area, of internal register, of timer or counter) were set to the specified conditions automatically or manually.	
Warm Restart	In the warm restart mode, The power supply Off occurrence will be informed to the user program and the PLC system restarts with the previous user-defined data and user program after the power supply Off.	
I/O Image Area	Internal memory area of the CPU module which used to hold I/O statuses.	
Watch Dog Timer	Supervisors the pre-set execution times of programs and warns if a program is not completed within the pre-set time.	
Function	Operation Unit which outputs immediately its operation result of an input, while four arithmetic operations comparison operation store their results in the inside of instructions.	
Function Block	Operation Units which store operation result in the inside of instruction such as timer and counter and use the operation results which have been stored through many scans.	
Symbolic Variable	Variables used after the user's definition of their names and types. Declarations as 'INPUT_0' = %IX0.0.2, 'RESULT = %MD1234' makes INPUT_0 and RESULT be able to used instead of %IX0.0.2 and %MD123 in programming.	
GMWIN	A peripheral device for the GLOFA-GM series. It executes program creation, edit, compile and debugging.	
FAM	Abbreviation of the word 'Factory Automation Monitoring S/W'. It is used to call S/W packages for process supervision.	
Task	It means startup conditions for a program. There are three types of periodic task, internal contact task and external contact task which starts by the input signals of external input modules.	

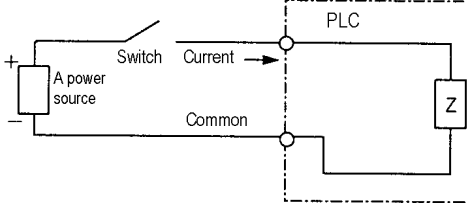
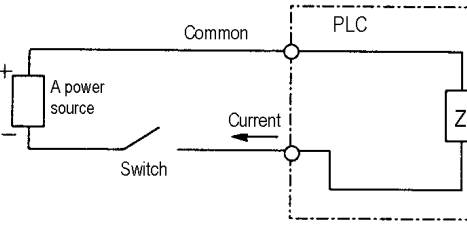
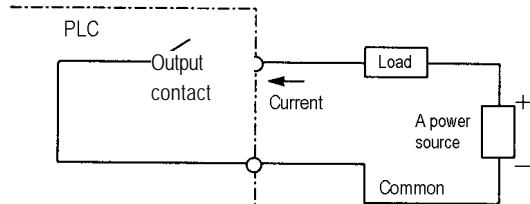
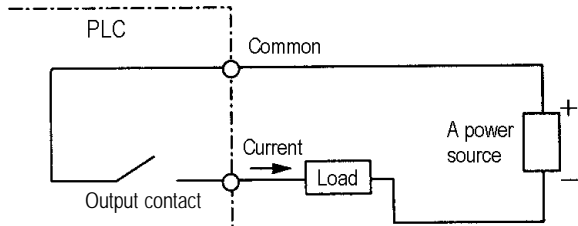
Terms	Definition	Remarks
Sink Input	<p>Current flows from the switch to the PLC input terminal if a input signal turns on.</p> 	
Source Input	<p>Current flows from the PLC input terminal to the switch after a input signal turns on.</p> 	
Sink Output	<p>Current flows from the load to the output terminal and the PLC output turn on.</p> 	
Source Output	<p>Current flows from the output terminal to the load and the PLC output turn on.</p> 	
Fnet	Fieldbus Network	
Cnet	Computer Network	