

## CHAPTER 3. INSTALLATION AND WIRING

### 3.1 Installation

#### 3.1.1 Installation Environment

This module has high reliability regardless of its installation ambience. But check the following for system in higher reliability and stability.

##### 1) Ambience requirements

Avoid installing this unit in locations which are subjected or exposed to :

- Water leakage and a large amount of dust, power and other conductive powder, oil mist, salt, of organic solvent
- Mechanical vibrations of impacts transmitted directly to the module body
- Direct sunlight.
- Dew condensation due to sudden temperature change.
- High or low temperatures (outside the range of 0-55°C)

##### 2) Installation and wiring

- During wiring or other work, do not allow any wire scraps to enter into the PLC.
- Install it on locations that are convenient for operation.
- Make sure that it is not located near high voltage equipment on the same panel.
- Make sure that the distance from the walls of duct and external equipment be 50 mm or more.
- Be sure to be grounded to locations that have good noise immunity.

#### 3.1.2 Installation Precautions

From unpacking to installation of the D/A conversion module, be sure to check the following:

- 1) Do not drop it off, and make sure that strong impacts should not be applied.
- 2) Do not dismount printed circuit board(PCB) from the case. It can cause malfunctions.
- 3) During wiring, be sure to check any foreign matter like wire scraps should not enter into the upper side of the PLC, and in the event that foreign matte entered into it, always eliminate it.
- 4) Be sure to disconnect electrical power before mounting or dismounting the module.

**3.2 Wiring**

**3.2.1 Wiring Precautions**

- 1) Separate AC and external input signal of D/A conversion module wiring not to be affected by surge or induced noise in the AC.
- 2) External wiring has to be at least AWG22(0.3 mm<sup>2</sup>) and be selected in consideration of operating ambience and/or allowable current.
- 3) Separate wiring from devices and/or substances generating intense heat, and oil not to make short-circuit which leads to damage and/or mis-operation.
- 4) Identify the polarity of terminal block before external power supply is made connected.
- 5) Separate external wiring sufficiently from high voltage and power supply cable not to cause induced failure and/or malfunction.
- 6) Don't put the power cable in front of the LED display ( To read the digital value on the LED correctly)

**3.2.2 Wiring Examples**

1) G6F-DA2V

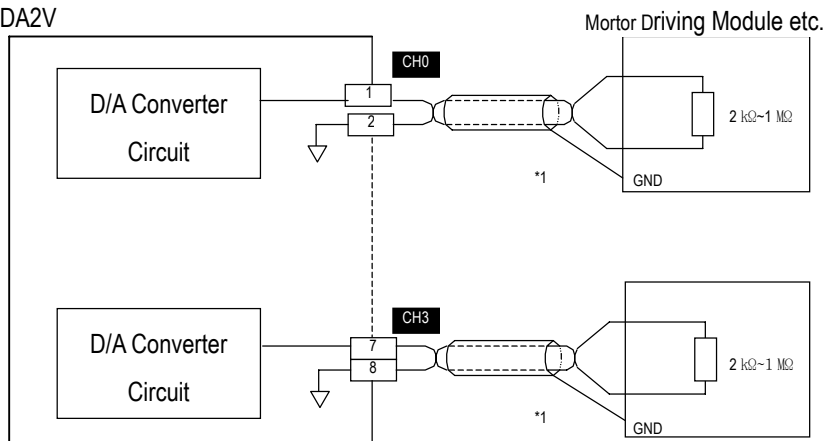

2) G3F-DA4I

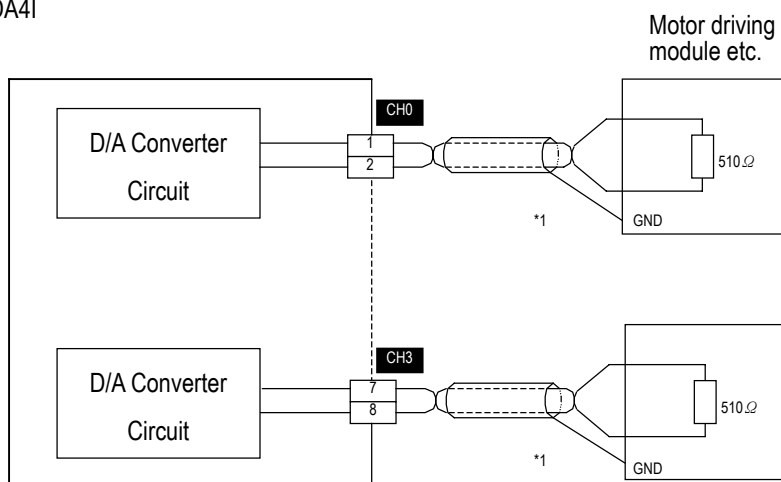

\*1 For the cable, use a two-core twisted shielded wire.