

Chapter 2. SPECIFICATIONS

2.1 General Specifications

Table 2.1 shows general specifications of the GLOFA GM series and MASTER-K series.

No	Item	Specifications	Standards				
1	Operating ambient temperature	0 ~ 55 (32 ~ 131)					
2	Storage ambient temperature	-25 ~ 75 (-13~167)					
3	Operating ambient humidity	5 ~ 95%RH, non-condensing					
4	Storage ambient humidity	5 ~ 95%RH, non-condensing					
5	Vibration	Occasional vibration				10 times in each direction for X, Y, Z	IEC 61131-2
		Frequency	Acceleration	Amplitude	Sweep count		
		10 f 57 Hz	-	0.075 mm			
		57 f 150 Hz	0.001 Kg	-			
		Continuous vibration					
		Frequency	Acceleration	Amplitude			
		10 f 57 Hz	-	0.035 mm			
		57 f 150 Hz	4.9m/s ²	-			
6	Shocks	*Maximum shock acceleration: 15g *Duration time :11 ms *Pulse wave: half sine wave pulse(3 times in each of X, Y and Z directions)				IEC 61131-2	
7	Noise immunity	impulse noise	± 1,500 V				
		Electrostatic discharge	Voltage :4kV(contact discharge)			IEC 61131-2 IEC 1000-4-2	
		Radiated electromagnetic field	27 ~ 500 MHz, 10 V/m			IEC 61131-2 IEC 1000-4-3	
		Fast transient burst noise	Severity Level	All power modules	Digital I/Os (Ue < 24 V) Analog I/Os communication I/Os	IEC 61131-2 IEC 1000-4-4	
		Voltage	2 kV	1 kV	0.25 kV		
8	Operating	Free from corrosive gases and excessive dust					
9	Altitude for use	Up to 2,000m(6,562ft)					
10	Pollution degree	2 or lower					
11	Cooling method	Self-cooling					

[Table 2.1] General Specifications

Remark

1) IEC(International Electrotechnical Commission)

: The international civilian organization which produces standards for electrical and electronics industry.

2) Pollution degree

: It indicates a standard of operating ambient pollution level.

The pollution degree 2 means the condition in which normally, only non-conductive pollution occurs. Occasionally, however, a temporary conductivity caused by condensation shall be expected.

2.2 Performance Specifications

The following show various specifications of the High-speed counting module including basic performance specifications, input specifications, limit switch input specifications and transistor output specifications.

2.2.1 Basic Performance Specification

Item		Specifications		
		G3F - HSCA	G4F - HSCA	G6F - HSCA
I/O Points		32 Points	16 Points	
Number of Channels		2 channels	1 channel	
Counter input signal	Signal	Phase A, Phase B or Phase Z		
	Signal level	5 / 12 / 24 VDC (7-13mA)		
	Signal type	Voltage input		
Counting range		0 to 16,777,215 (24 Bits Binary)		
Counting speed		Maximum 50 kHz		
Limit switch input		24 VDC		
Setting Increment /Decrement	1-phase input	Set by program or Phase B is set		
	2-phase input	Set by difference of phase automatically		
External output	Type	Out 1, Out 2(One among ' > ' , ' = ' and ' < ' is selected)		
	Signal type	Transistor output (open collector output, 10 to 30 V)		
Multiplication		The multiplication factor for the input pulse may be set to 1, 2 or 4 (Selected by DIP Switch adjustment)		
Current consumption		5 VDC, 0.3 A	5 VDC,0.25 A	5 VDC,0.18 A
Weight		620 g	330 g	160 g

2.2.2 Input Specifications

Item	Specifications	
Rated input voltage / current	5 VDC (7 mA)	
	12 VDC (7 mA)	
	24 VDC (13 mA)	
' On ' guarantee voltage	5 VDC	4.5 V or more
	12 VDC	11 V or more
	24 VDC	14 V or more
' Off ' guarantee voltage	5 VDC	0.8 or less
	12 VDC	1.5 V or less
	24 VDC	2.5 V or less

2.2.3 Limit Switch (L/S) Input Specifications

Item	Specifications
Input voltage	24 VDC
' On ' guarantee voltage	19 VDC or more
' Off ' guarantee voltage	6 VDC or less
On Delay Time	1.5 ms or less
Off Delay Time	2 ms or less

2.2.4 Transistor Output Specifications

Item	Specifications
Rated output	24 VDC, 200 mA
Leakage current	50 μ A or less
Saturated voltage	1.3V
On Delay Time	50 μ s or less
Off Delay Time	50 μ s or less

2.3 Names of Parts and Functions

2.3.1 Names of Parts and Functions

The names of parts and functions of the high speed counter module are shown as below

1) G3F-HSCA

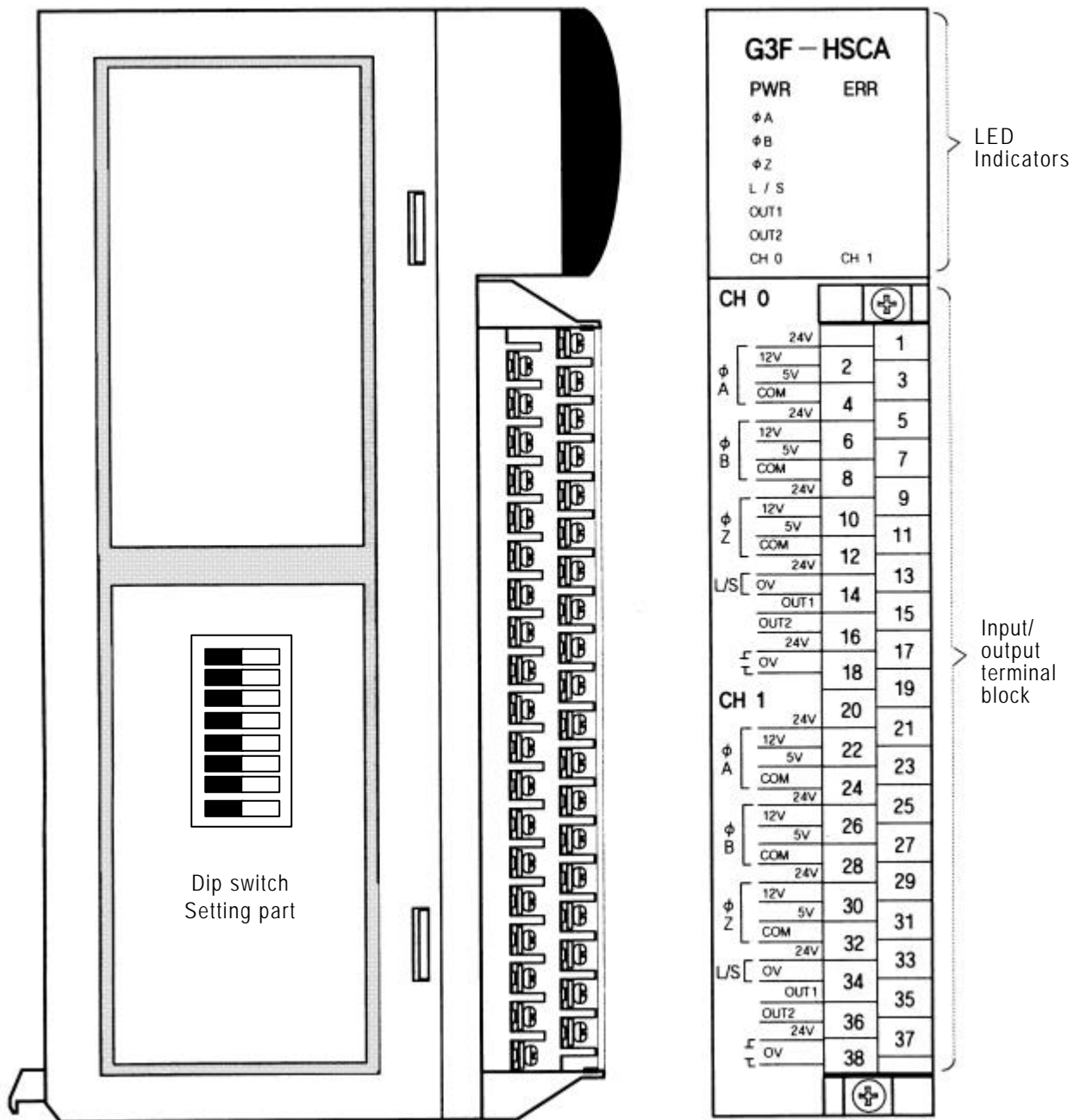

2) G4F-HSCA

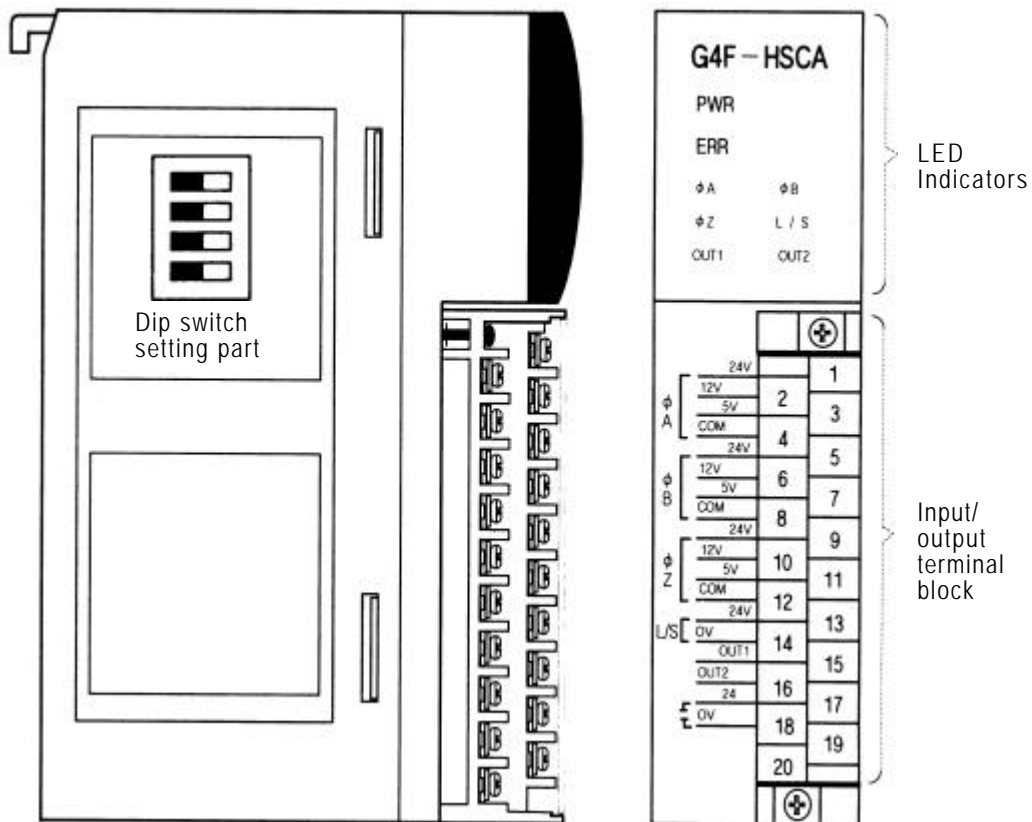

3) G6F-

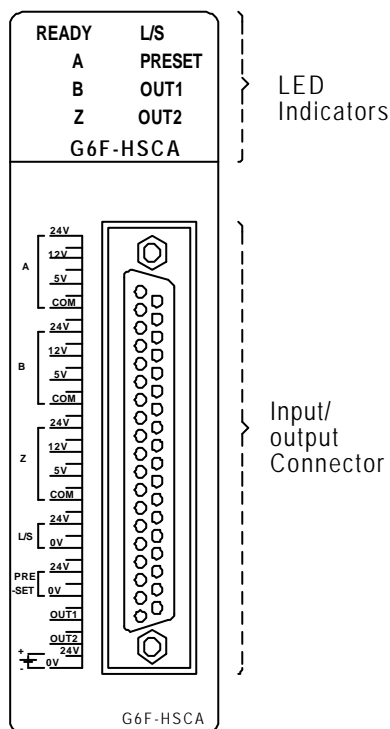

2.3.2 Function of LED Indicators

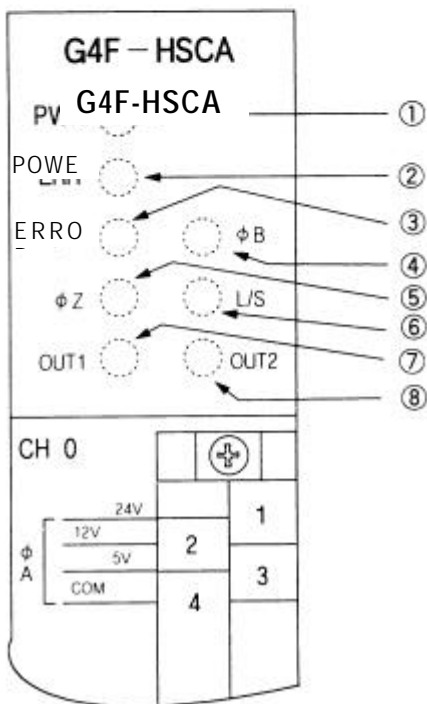
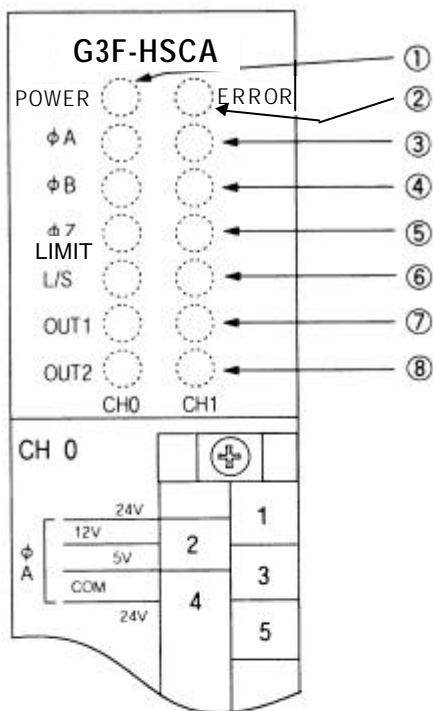

No.	Description
	Power LED Turns On when the power is applied.
	Error LED Turns on for 0.5 sec when the power is applied and then turns off if the system is normally running. Flickers with 0.1 sec, 0.2 sec or 0.3 sec cycle according to the error content, If an error has occurred.
	Phase A pulse input LED Turns on when voltage is applied to phase A input terminal.
	Phase B pulse input LED Turns on when voltage is applied to phase B input terminal
	Phase Z pulse input LED Turns on when voltage is applied to phase B input terminal
	Limit switch input LED Turns on when voltage is applied to limit switch input terminal
	OUT1 output LED Indicate the magnitude comparison result of CMP 1
	OUT2 output LED Indicate the magnitude comparison result of CMP 2
	Preset Switch Input (PRESET) Turns on when voltage is applied to preset switch input terminal

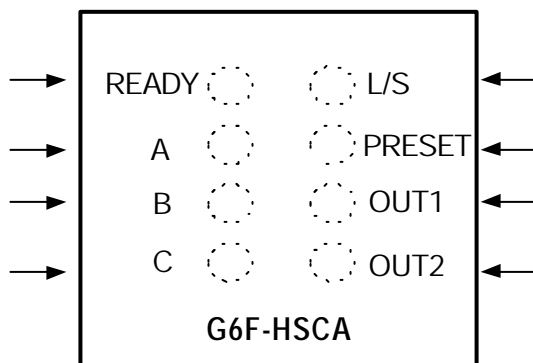

2.3.3 DIP Switch Setting Part

The DIP Switch settings are used for phase-2/ phase-1 operation mode specification, Increment / Decrement count method specification at 1-phase operation, and multiplication specification at 2-phase operation.

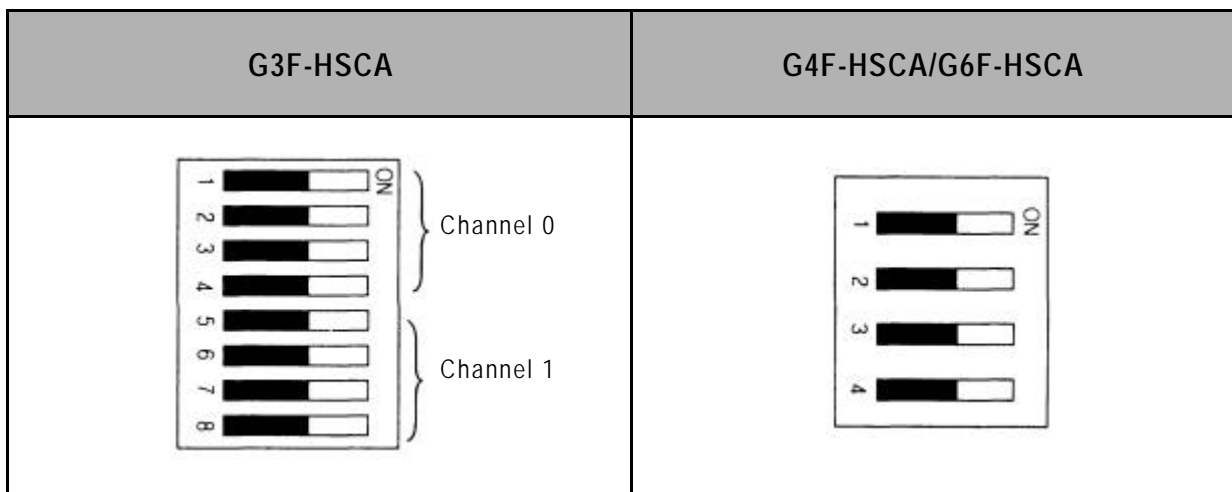

Switch			Functions	
G3F-HSCA		G4F-HSCA, G6F-HSCA	Status	Descriptions
channel 0	channel 1			
SW 1	SW 5	SW 1	On	Specifies the 2 – phase pulse operation mode.
			Off	Specifies the 1 – phase pulse operation mode.
SW 2	SW 6	SW 2	On	Specifies the phase B pulse input mode as increment/decrement count method at 1 – phase pulse inputs
			Off	Specifies the program input mode as increment/decrement count method at 1 – phase pulse inputs
SW 3	SW 7	SW 3	On On	Specifies as multiply 1
			On Off	Specifies multiply 2
SW 4	SW 8	SW 4	Off On	No multiplication is applied
			Off Off	Specifies multiply 4

2.3.4 Input / Output Terminal Block

1) G3F-HSCA/G4F-HSCA

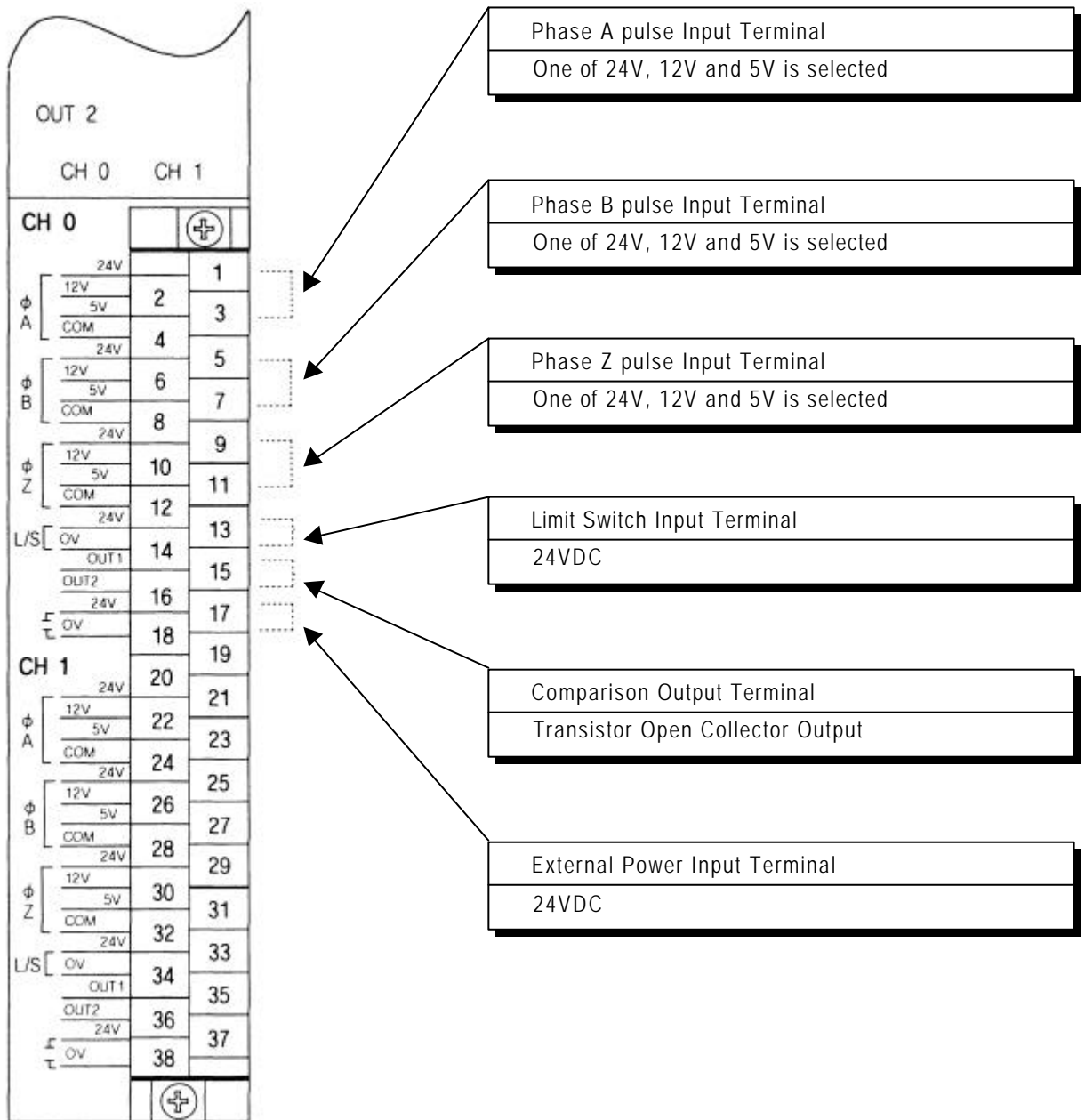

Remark
 The above input/output terminals the CH0 and CH1 of the G3F-HSCA use the same input/output terminals as shown above.
 The G4F-HSCA input/output terminal's configuration is also same as above.

2) G6F-HSCA

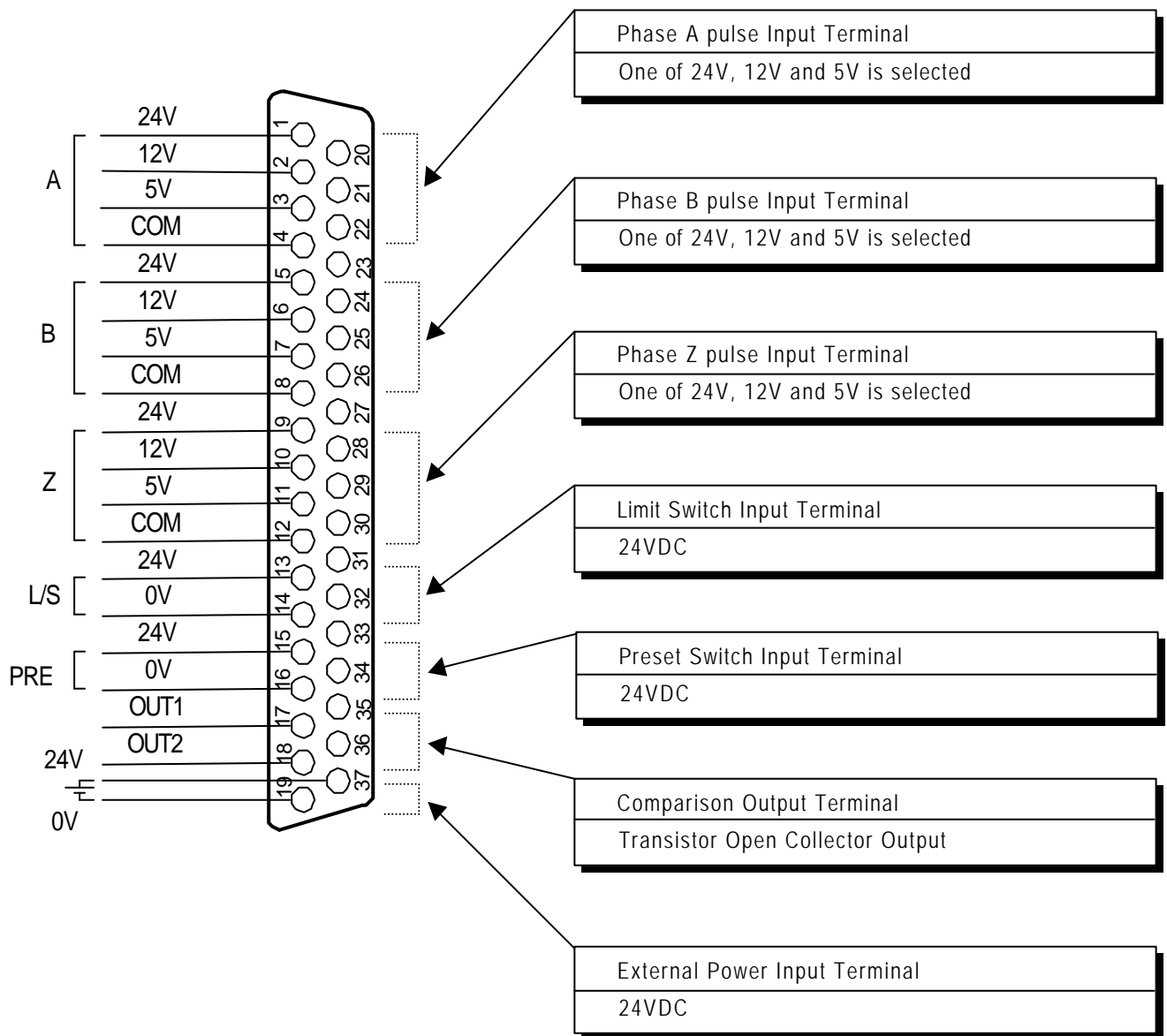

Remark

The G6F-HSCA module has external preset input terminal(15, 16). And it is possible to used to preset value setting signal of external.

2.4 Interface with External Devices

Table 2.1 and Table 2.2 shows the list for interface with external devices.

1) G3F-HSCA/G4F-HSCA

I/O	Internal Current	Terminal No.		Signal Name	Operation	Input guaranteed Voltage
		CH 0	C H1			
Input		1	21	24 V, Phase A pulse input	On	14~26.4 V
					Off	2.5 V
		2	22	12 V, Phase A pulse input	On	11~13.2 V
					Off	1.5 V
		3	23	5 V, Phase A pulse input	On	4.5~5.5 V
					Off	0.8 V or less
		4	24	COM		
		5	25	24 V, Phase B pulse input	On	14~26.4 V
					Off	2.5 V
		6	26	12 V, Phase B pulse input	On	11~13.2 V
					Off	1.5 V
		7	27	5 V, Phase B pulse input	On	4.5~5.5 V
			Off	0.8 V or less		
8	28	COM				
9	29	24 V, Phase Z pulse input	On	14~26.4 V		
			Off	2.5 V		
10	30	12 V, Phase Z pulse input	On	11~13.2 V		
			Off	1.5 V		
11	31	5 V, Phase Z pulse input	On	4.5~5.5 V		
			Off	0.8 V or less		
12	32	COM				
Input		13	33	L/S input, 24 V	On	19~26.4 V
					Off	6 V or less
14	34	L/S COM				
Output		15	35	Open collector output OUT1	Rated output: 24VDC, 200 mA Response time: Off→On 50 μs or less On→Off 50 μs or less	
		16	36	Open collector output OUT1		
		17	37	External power supply output 24 V	Input voltage 10.2 ~ 30 V	

Chapter 2. SPECIFICATIONS

		18	38	External power supply COM 0 V	
--	--	----	----	-------------------------------	--

[Table 2.1] External interface list (G3F-HSCA / G4F-HSCA)

2) G6F-HSCA

I/O	Internal Current	Terminal pin No.	Signal Name	Operation	Input guaranteed Voltage
Input		1	24 V, Phase A pulse input	On	14~26.4 V
				Off	2.5 V
		2	12 V, Phase A pulse input	On	11~13.2 V
				Off	1.5 V
		3	5 V, Phase A pulse input	On	4.5~5.5 V
				Off	0.8 V or less
		4	COM		
		5	24 V, Phase B pulse input	On	14~26.4 V
				Off	2.5 V
		6	12 V, Phase B pulse input	On	11~13.2 V
				Off	1.5 V
		7	5 V, Phase B pulse input	On	4.5~5.5 V
		Off	0.8 V or less		
8	COM				
9	24 V, Phase Z pulse input	On	14~26.4 V		
		Off	2.5 V		
10	12 V, Phase Z pulse input	On	11~13.2 V		
		Off	1.5 V		
11	5 V, Phase Z pulse input	On	4.5~5.5 V		
		Off	0.8 V or less		
12	COM				
Input		13	L/S input 24 V	On	19~26.4 V
				Off	6 V or less
		14	L/S COM		
		15	Preset input 24V	On	19~26.4 V
		Off	6 V or less		
16	L/S COM				
Output		17	Open collector output OUT1	Rated output: 24VDC, 200 mA Response time: Off→On 50 μs or less On→Off 50 μs or less	
		18	Open collector output OUT2		

Chapter 2. SPECIFICATIONS

		37	External power supply output 24 V	Input voltage 10.2 ~ 30 V
		19	External power supply COM 0 V	

[Table 2.2] External interface list (G6F-HSCA)

2.5 Output Mode of Encoder

- Open collector output

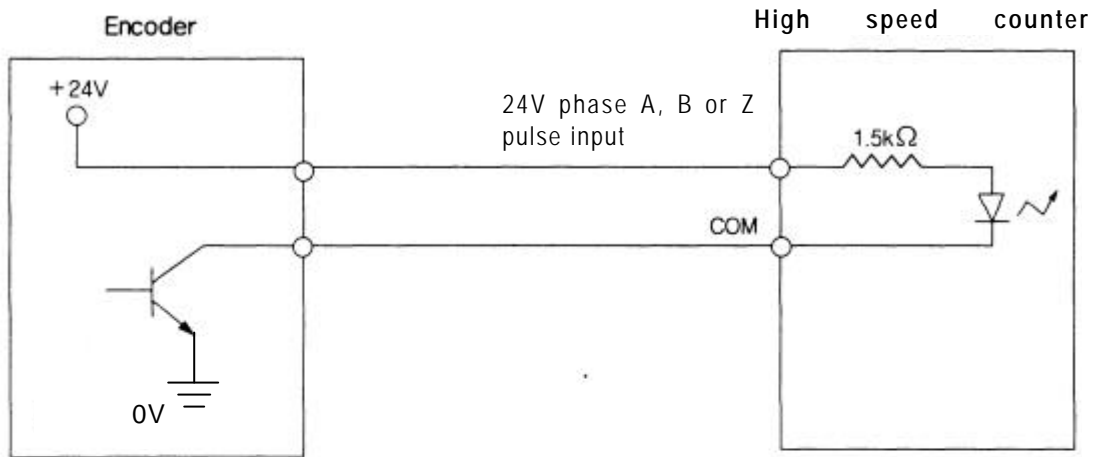

- Voltage output

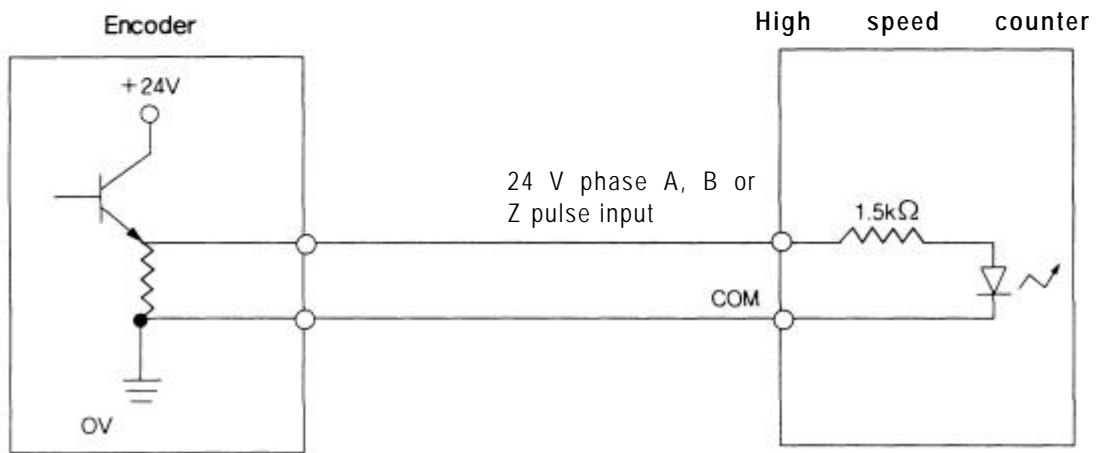

2.6 Function Descriptions

The High-speed counting module can count high-speed pulse which cannot be proceed with the CPU counting instructions (CTU,CTUD, etc.). Up to 24 bits binary (16,777,215) can be counted. Pulse input mode is classified into 1-Phase (Phase A) pulse input and 2-Phase (Phase B) pulse input. In 1-Phase pulse input mode, there are two kinds of increment/decrement count methods. One is specified by program and the other is specified by phase B pulse input signal. In 2-Phase pulse input mode, the increment/decrement count method is specified by the phase difference between phase A and B pulsed.

2.6.1 Operation Modes

1) 1-phase Operation Mode (Increment /Decrement Count by Program)

When Phase A pulse input rises, the counter performs increment or decrement count by decrement counter specification signal.

If the decrement counter specification signal is low the counter performs increment count, and if high, it performs decrement count.

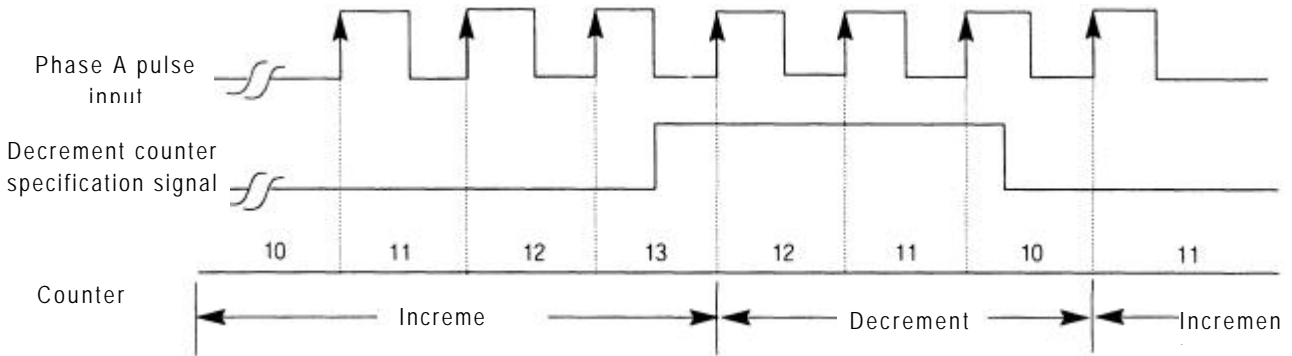

2) 1-phase Operation Mode (Increment /Decrement Count by Phase B Pulse Input)

When Phase A pulse input the counter performs increment or decrement count by Phase B pulse input.

If Phase B pulse input is low, it performs decrement count, and if high, it performs increment count.

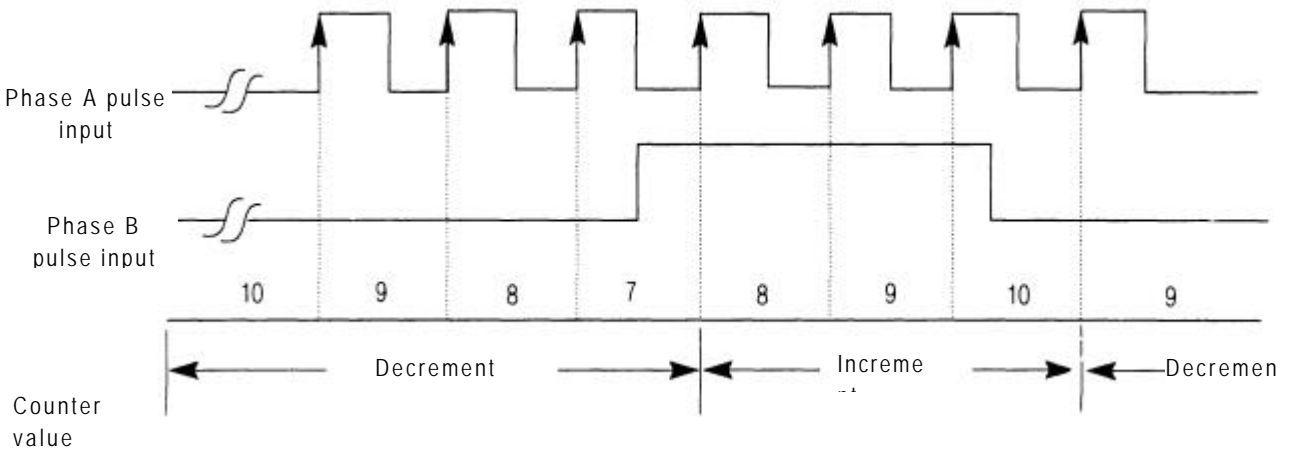

3) 2-Phase Operation Mode (Multiply 1)

When Phase A pulse-input leads Phase B, the counter performs increment count when phase B pulse-input leads phase A, it performs decrement count.

If Phase B pulse input is low when Phase A pulse input rises, the counter performs increment count.

If Phase B pulse input is low when phase A pulse input falls, it performs decrement count.

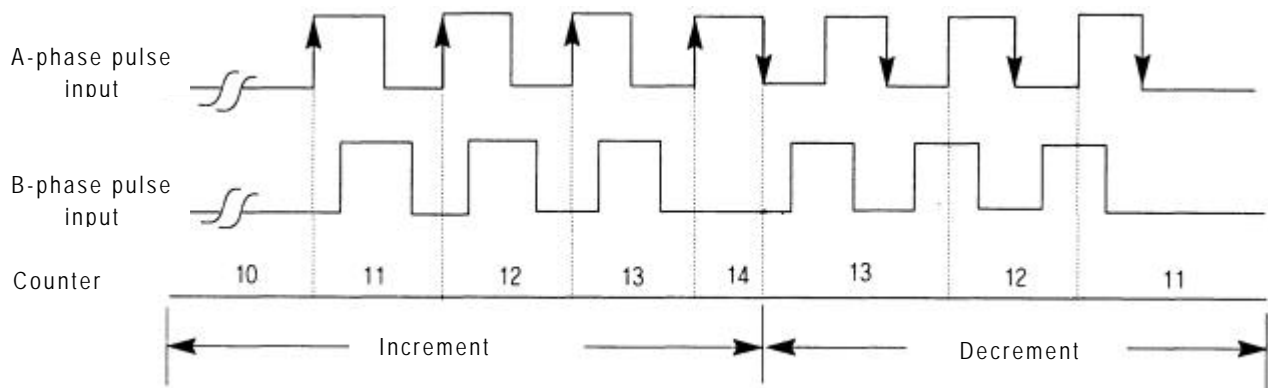

4) 2-Phase Operation Mode (Multiply 2)

When Phase A pulse-input leads Phase B, the counter performs increment count when phase B pulse-input leads phase A, it performs decrement count.

If Phase B pulse input is low when Phase A pulse input rises or it is high when phase A pulse input falls, the counter performs increment count.

If Phase B pulse input is high when Phase A pulse input rises or it is low when phase A pulse input falls, the counter performs decrement count.

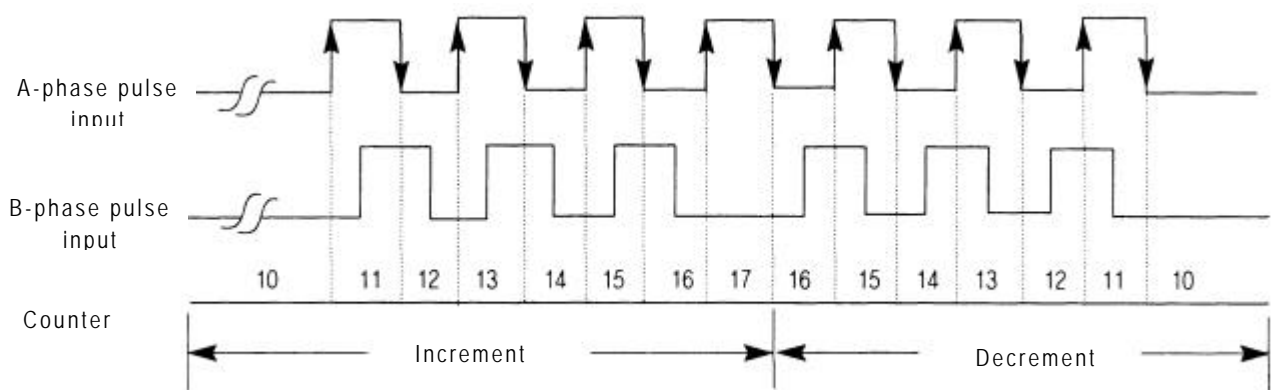

5) 2-phase Operation Mode (Multiply 4)

When Phase A pulse input leads Phase B pulse input, the counter performs increment count.
 When the other leads the one, it performs decrement count.
 The counting is performed when the Phase A and B pulse inputs rise or fall.

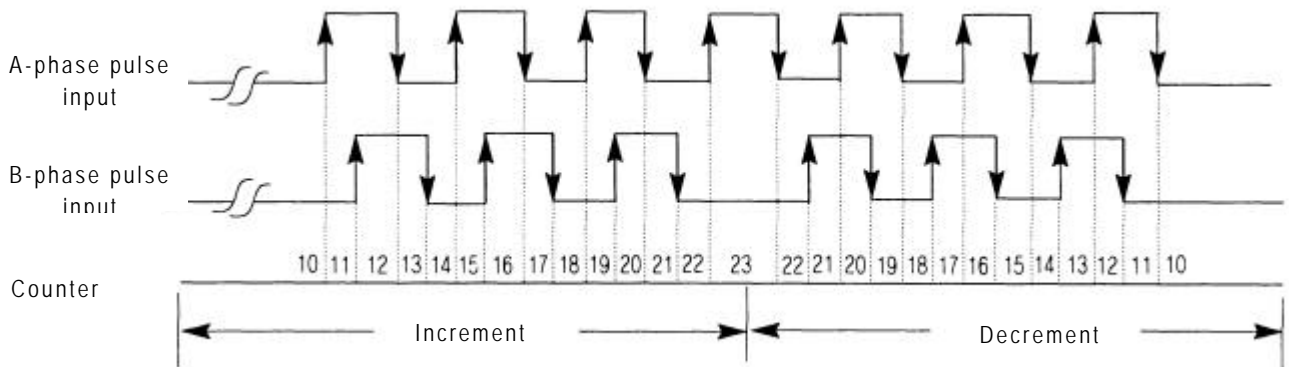

2.6.2 Comparison Signal Output

The counting module has the function of comparison output, which outputs the result of magnitude comparison between the Current value (=current value) and a comparison value. There are two outputs in the comparison output and they can be used separately. The magnitude comparison mode can be set as shown in the below table.

Comparison mode	Settings
0	No magnitude comparison is performed.
1	Current value < Setting value
2	Current value = Setting value
3	Current value > Setting value
4	Current value < Setting value
5	Current value = Setting value
6	Current value > Setting value
7	Always On

The results as shown above will be indicated on the OUT1 LED or OUT2 LED regardless of the output. Output to the external terminal block is performed only when the output enable signal is ON.

1) Example When the Comparison Mode Is Set to 'Current Value < Setting Value'

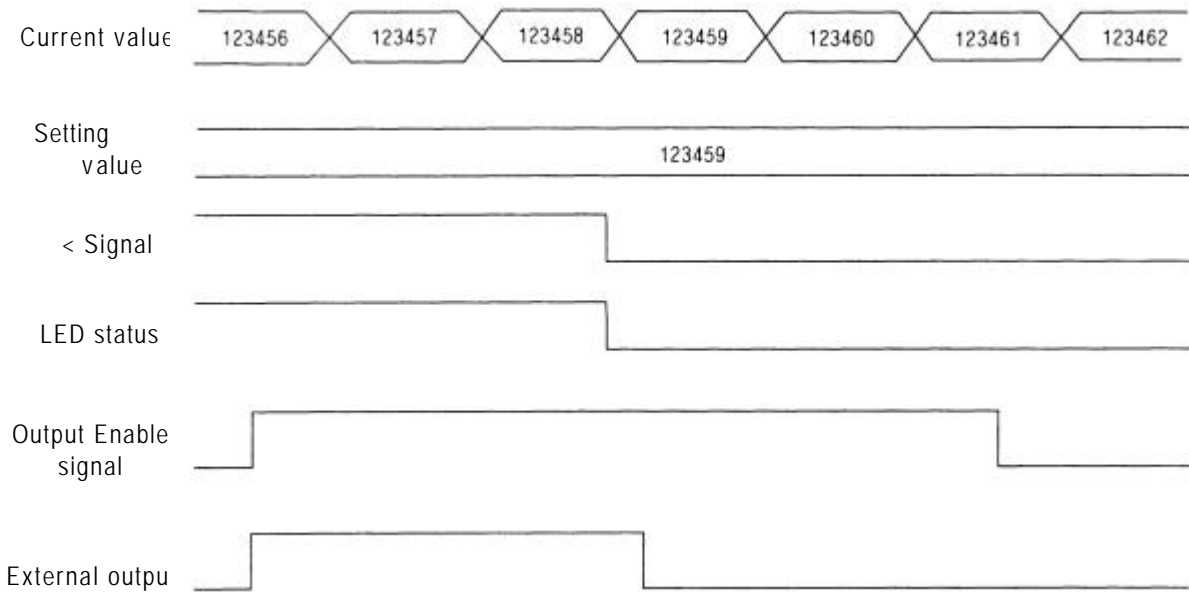

2) Example When the Comparison Mode Is Set to 'Current Value > Setting Value'



3) Example When the Comparison Mode Is Set to 'Current Value = Setting Value'

Contrary to the '>(GT)' and '<(LT)' signals, once the coincidence (=) signal is turned ON, it retains the ON state until the coincidence reset signal is turned ON.

The LED status is same as the coincidence signal. Output is performed only when the output enable signal is turned ON.

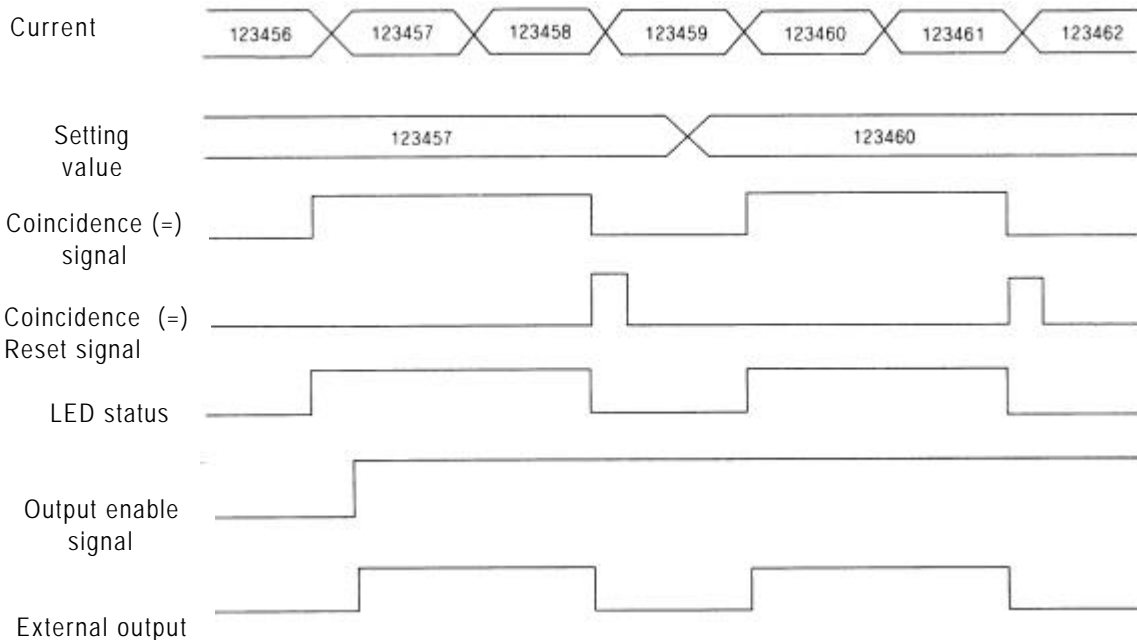

2.6.3 Home Signal

Home signal is operated only when the HOME-LATCH enable signal is turned on. Home signal turns on when both of phase Z pulse input and limit switch input is turned on. The count value retains '0' until the HOME-LATCH enable signal turns OFF though the counter continues its counting operation.

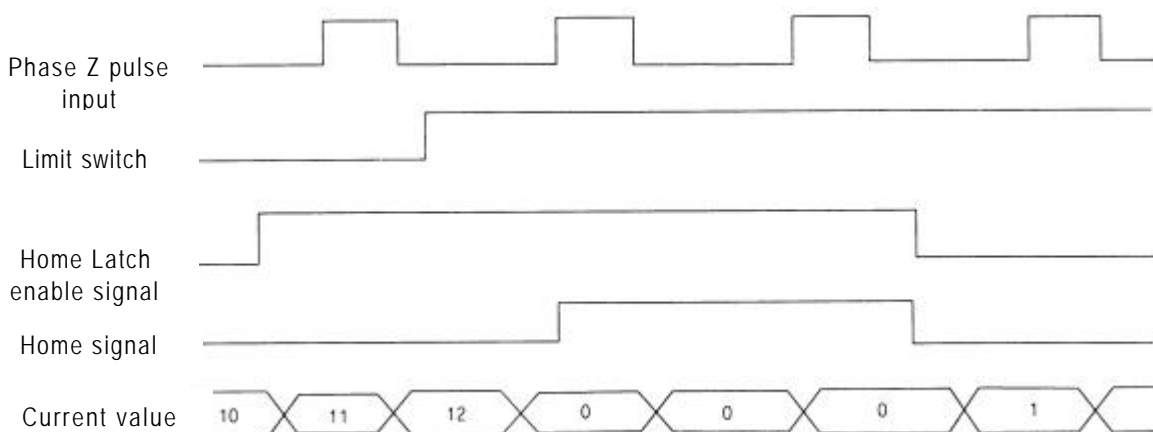

2.6.4 Carry Signal

The carry signal appears when the counter value changes from 16,777,215 to 0 during increment counting. The carry signal retains its ON State until the carry reset signal turns on. If the home signal is input, the carry signal will be cleared.

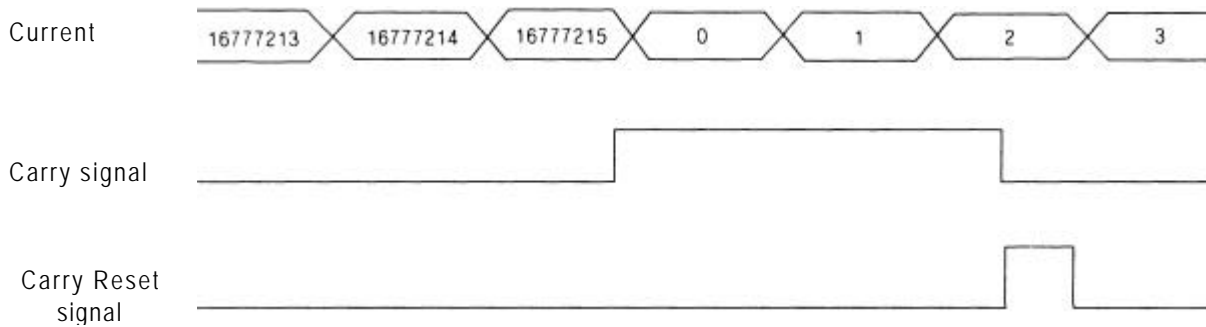

2.6.5 Borrow Signal

The borrow signal appears when the counter value changes from 0 to 16,777,215 during decrement counting. The borrow signal retains its ON State until the borrow reset signal turns on. If the home signal is input, the borrow signal will be cleared. The borrow reset signal is used together with the carry reset signal.

