

Chapter 3. INSTALLATION AND WIRING

3.1 Installation

3.1.1 Installation Ambience

This module has high reliability regardless of its installation ambience. But be sure to check the following for system in higher reliability and stability.

1) Ambience Requirements

Avoid installing this module in locations, which are subjected or exposed to:

Water leakage and dust a large amount of dust, powder and other conductive power, oil mist, salt, of organic solvent

Mechanical vibrations of impacts transmitted directly to the module body.

Direct sunlight.

Dew condensation due to sudden temperature change.

High or low temperatures (outside the range of 0-55)

2) Installing and Wiring

During wiring or other work, do not allow any wire scraps to enter into it.

Install it on locations that are convenient for operation.

Make sure that it is not located near high voltage equipment on the same panel.

Make sure that the distance from the walls of duct and external equipment be 50 mm or more.

Be sure to be grounded to locations that have good noise immunity

3.2 Wiring Precautions

When using High-speed inputs, take the following precautions against noise in wiring.

- 1) Be sure to use shielded twisted pair cables and provided class 3 grounding.
- 2) Separate a twisted pair cable from power cables or I/O line that may generate noise.
- 3) Use a stabilized power supply for pulse generator.
For 1-phase input, connect count-input signal only to phase A;
For 2-phase input, connect to phases A and B.

3.3 Wiring Example

3.3.1 5VDC Voltage Output Type Encoder

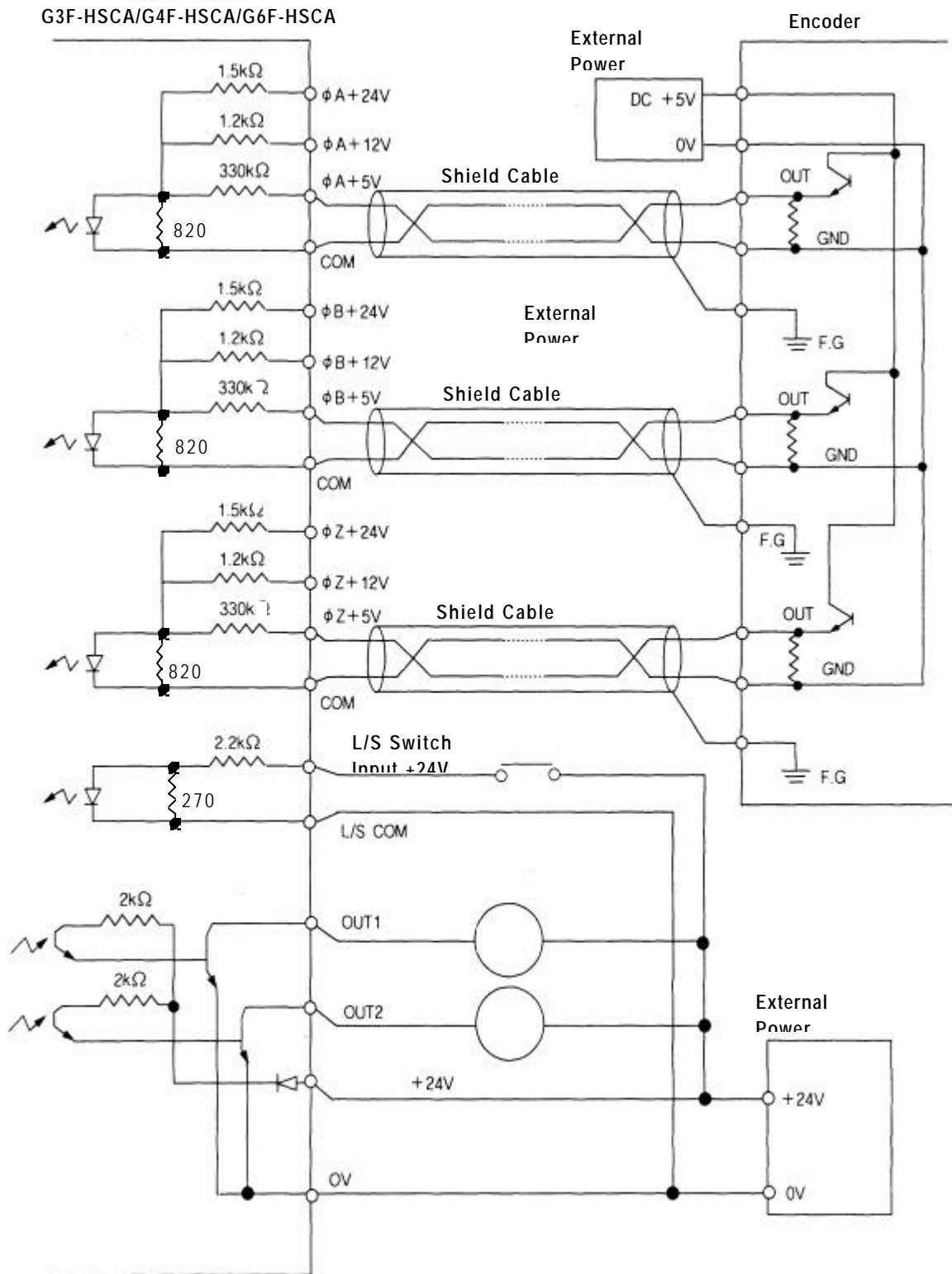

3.3.2 24VDC NPN Open Collector Type Encoder

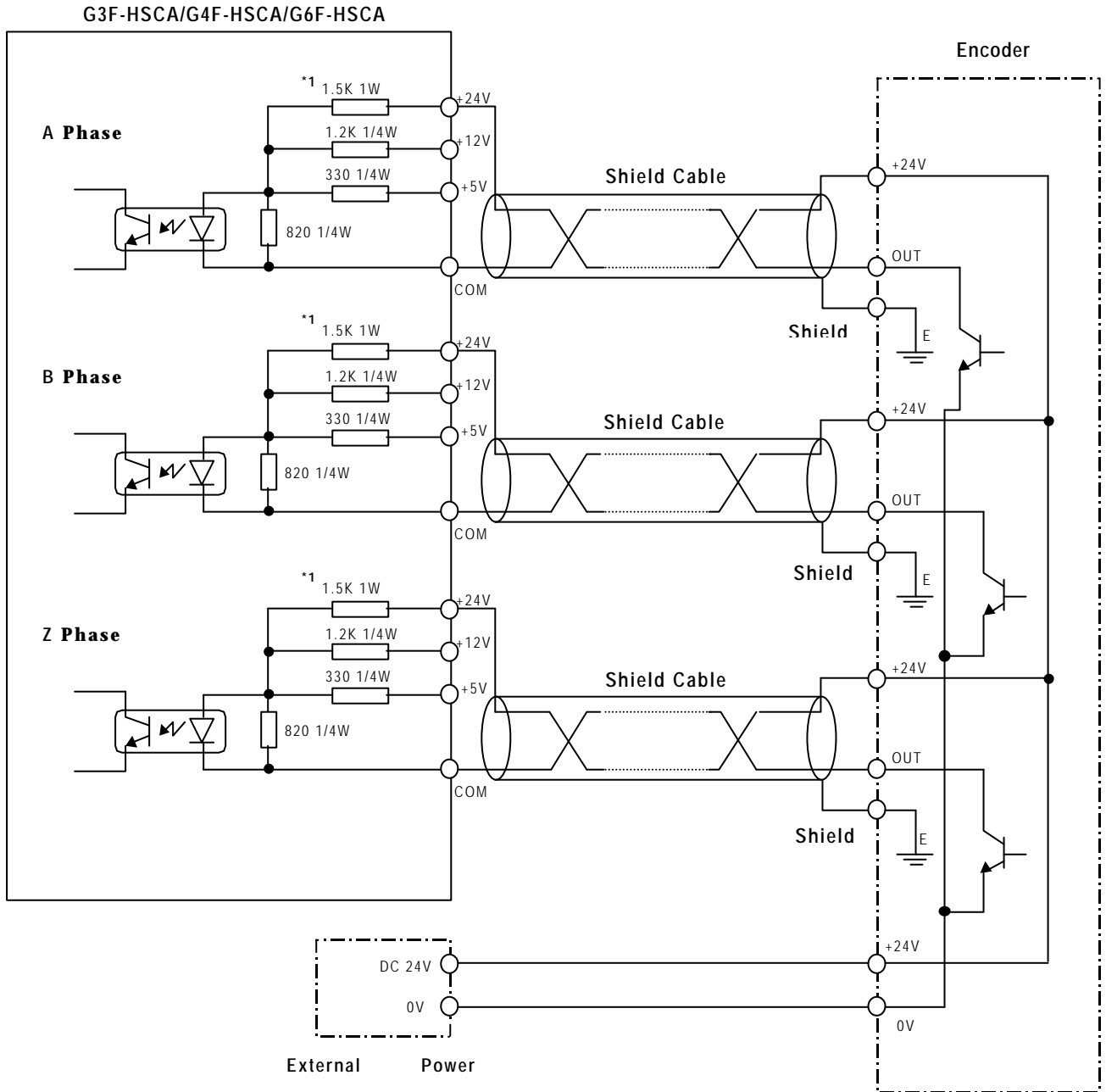

3.3.3 24VDC PNP Open Collector Encoder

