

Chapter 4 Communication Programming

4.1 Overview

There are two kinds of Programming methods using the Smart I/O series.
For further information, please refer to the user's manual related to "master module".

1) High Speed Link

High Speed Link is used when other station's data or information is periodically exchanged at every specific time. By referring the changing data of its own station or other station periodically, it enables to utilize the data to the system effectively and communicates by setting the simple parameter.

The setting method for GLOFA series is to designate its own area and the area of other station to send or receive and data size, station no. in GMWIN parameter setting (for MASTER-K, in KGLWIN parameter setting) and then carry out the communication. Data size is at least 1 word (16 points) for communication and Rnet communication is available up to 3,840 words. The communication period is available to set max. 20ms up to 10 sec. according to the communication contents.

As it is available to communicate with other station by simple parameter setting, it is easy to use this program and the high speed process of internal data enables to process lots of data at the same time periodically.

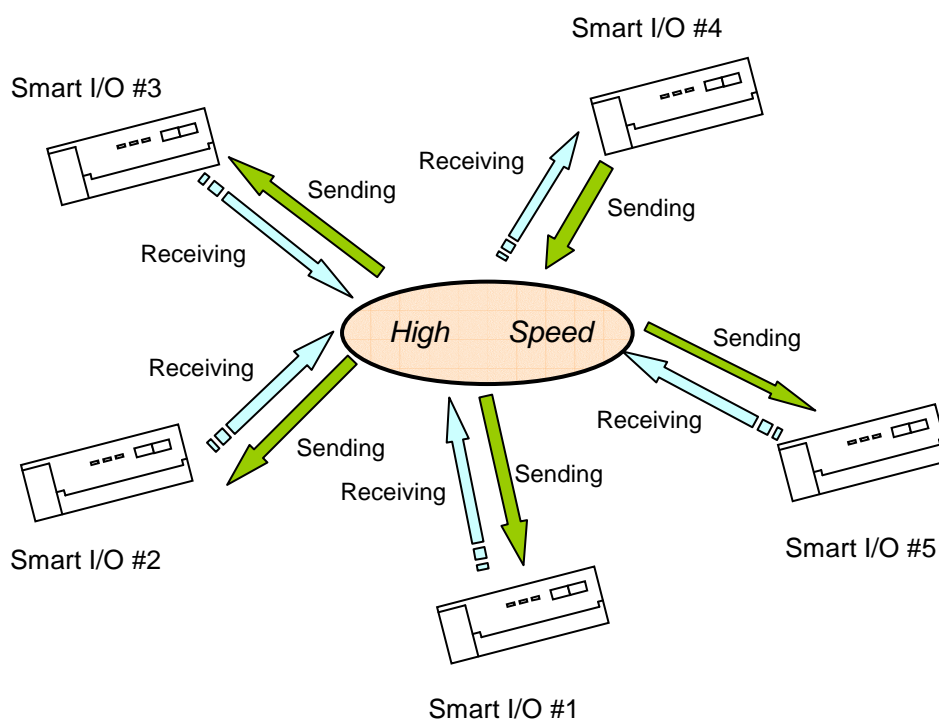

Chapter 4 Communication Programming

2) *Function Block*(GLOFA-GM) / *Command*(MASTER-K)

High Speed Link is periodic communication, but communication by *Function Block*/command is the service to communicate when the specific event to communicate with other station occurs. In case that the error occurs in other station which results in sending this content to other other station or when specific contact is entered to communicate, it is available to use *Function Block*/command.

The program method is written by designating Enable condition, communication module installed module position, station no., data area of its own station, the area of other station using *Function Block* per type made by GMWIN program mode for GLOFA series (by KGLWIN program mode for MASTER-K series) in advance and command.

Data size to communicate in *High Speed Link* is word (16 points) unit but in GLOFA *Function Block*, it is available to communicate with each other station per data type such as Bit, Byte, Word etc. and in MASTER-K, also by Word unit.

Difference between *High Speed Link* operation and the operation by *Function Block*/command

Contents	<i>High Speed Link</i>	<i>Function Block</i> /command
Basic unit of TX/RX data	1word(16 points)	GLOFA : available per data type (Bit, Byte, Word etc.) MASTER-K : supports only Word type.
Communication period	20ms(per scan) ~ 10sec	Performs whenever Enable condition of communication program starts.
Operation method	Parameter setting→ Download to PLC→ <i>High Speed Link</i> allowed→ run	GLOFA : Compile→ Download to PLC→ Run MASTER-K : Download to PLC→ Run
Control by CPU operation mode key	<i>High Speed Link</i> is performed regardless of the CPU states(RUN, STOP, PAUSE)	Performs the operation following to the key condition of CPU module.

Remark

- 1) *High Speed Link* service is used only for Profibus-DP, DeviceNet, Rnet series from Smart I/O series. Configuration tool to operate the corresponding module is provided separately.
- 2) *Function Block* service is used for Modbus communication programming and for further information, refer to the user's manual.

4.2 High Speed Link

4.2.1 Overview

High Speed Link is a communication sevice which transmits data by setting parameter(TX/RX size, period of TX/RX, area of TX/RX and storage).

- Setting *High Speed Link* block :

- (1) In case that there are several areas for sending/receiving, it is available to set max.64 block (32 for seinding, 32 for receiving) respectively.
- (2) Available to set 60 words per block.
- (3) Available to use 3,840 words for max. link point.

- Sending/receiving period setting function :

As the user can set sending/receiving period per each block, it is available to set the sending/receiving period from 20ms (every scan) to 10 sec. dividing into the area which needs specially rapid sending/receiving and the area not needed.

- Sending/receiving area setting :

It is available to set sending/receiving area per data block according to setting I/O address.

- *High Speed Link* information provision function :

By providing the user with *High Speed Link* information by the user keyword, it enables to build reliable communication system easily.

Maximum *High Speed Link* points according to device type(master standard)

Classification		Max. communication point(word)	Max. sending point(word)	Max. block no.	Max. point per block (word)	Remark
Smart I/O series	G3/4/6/7L-RUEA	3,840	1,920	64(0-63)	60	Rnet I/F Module
	G3/4/6L-PUEA/PUEB	1,792	1,792	64(0-63)	60	Pnet I/F Module
	G4/6L-DUEA	128	128	64(0-63)	60	Dnet I/F Module

4.2.2 High Speed Link Sending/Receiving Data Processing

Sending/receiving data processing in *High Speed Link* can be described as follows.

Ex) This is the example to send/receive the data from local master (0 station) to Smart I/O station. This is the map to send/receive the data from/to the corresponding remote station when output module is allocated by 1,2,3 station respectively and input module is set as 4,5,6 station. The address, sending/receiving period, data size of Smart I/O station is as follows.

High Speed Link parameters have 32 blocks no. for sending and 32 blocks no. for receiving to send/receive the data and Block no. can be assigned and used from 0 to 63 for sending/receiving.

Generally, when sending the data, the sender is required to determine data to read and block number to send without designating the no. of other station. But in case that it is set by the remote (for example: Smart I/O series), the user is required to determine the station no. of Remote station (node) and block no. to send, and data sending/receiving mode for the remote station.

The following is the example of sending/receiving parameter setting for Smart I/O series that is composed of input module and output module. This sends/receives the data from master that tries to access Smart I/O module to each remote station. The block no. data address, communication period, data size of the corresponding module from local GMWIN or KGLWIN shall be set in *High Speed Link* parameter. In this case, you should pay attention that the block no. should be different regardless of I/O module in order to send/receive the desired data.

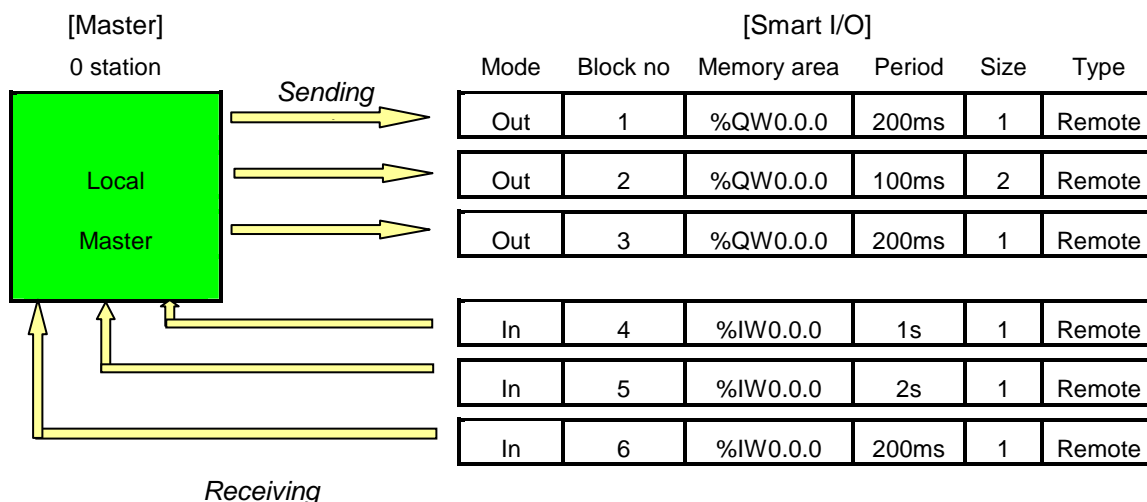

4.2.3 Operation Order by High Speed Link

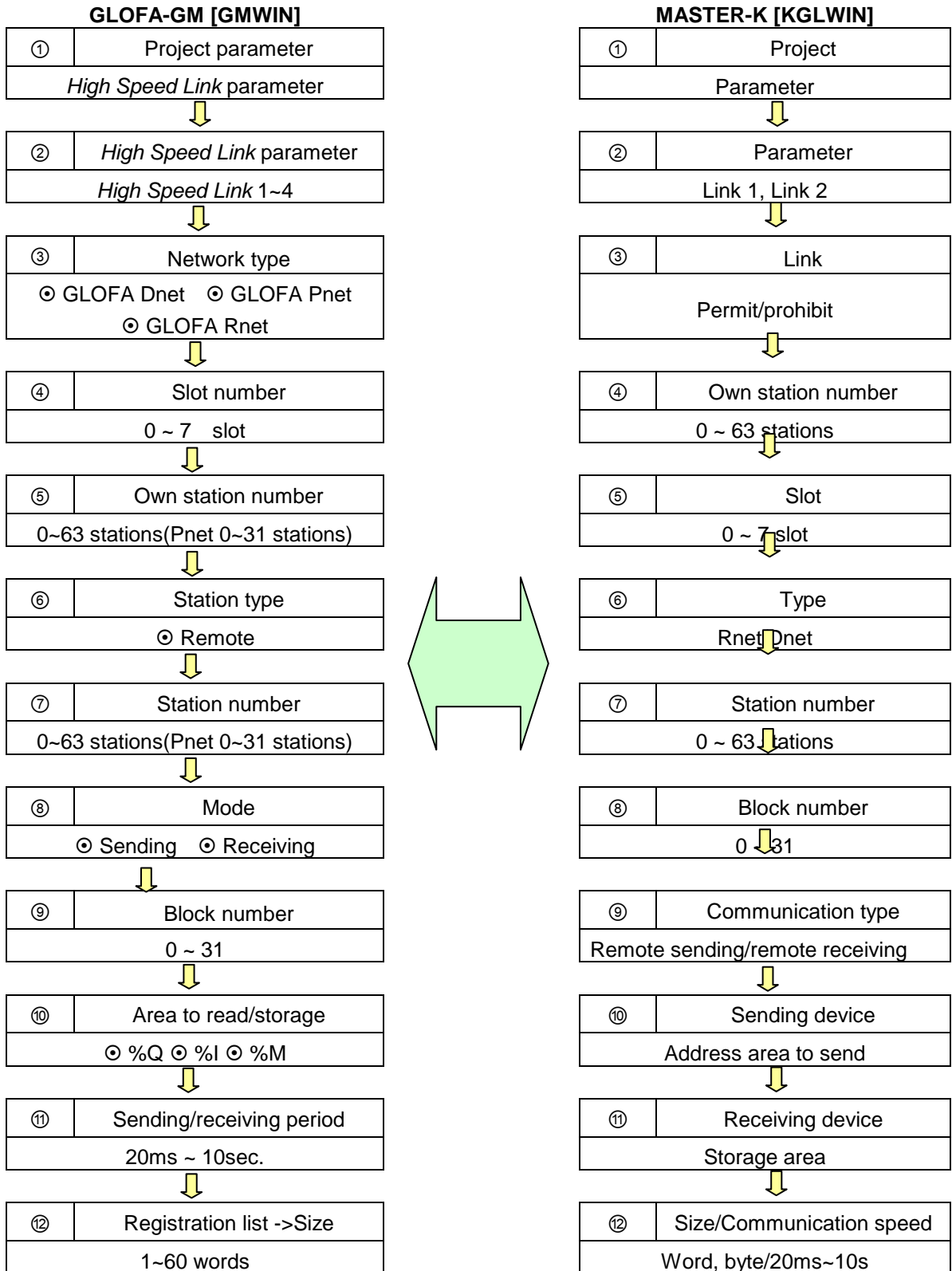

4.2.4 GMWIN's Setting of *High Speed Link* Parameter

High Speed Link parameter selects link parameter from GMWIN project menu and sets the corresponding item and the setting order and the function per item are shown as follows.

1) *High Speed Link* Project Setting

If selecting *High Speed Link* parameter from GMWIN project basic screen below, it shows the *High Speed Link* parameter basic screen and the user can select the corresponding item.

GMWIN Project Basic Screen

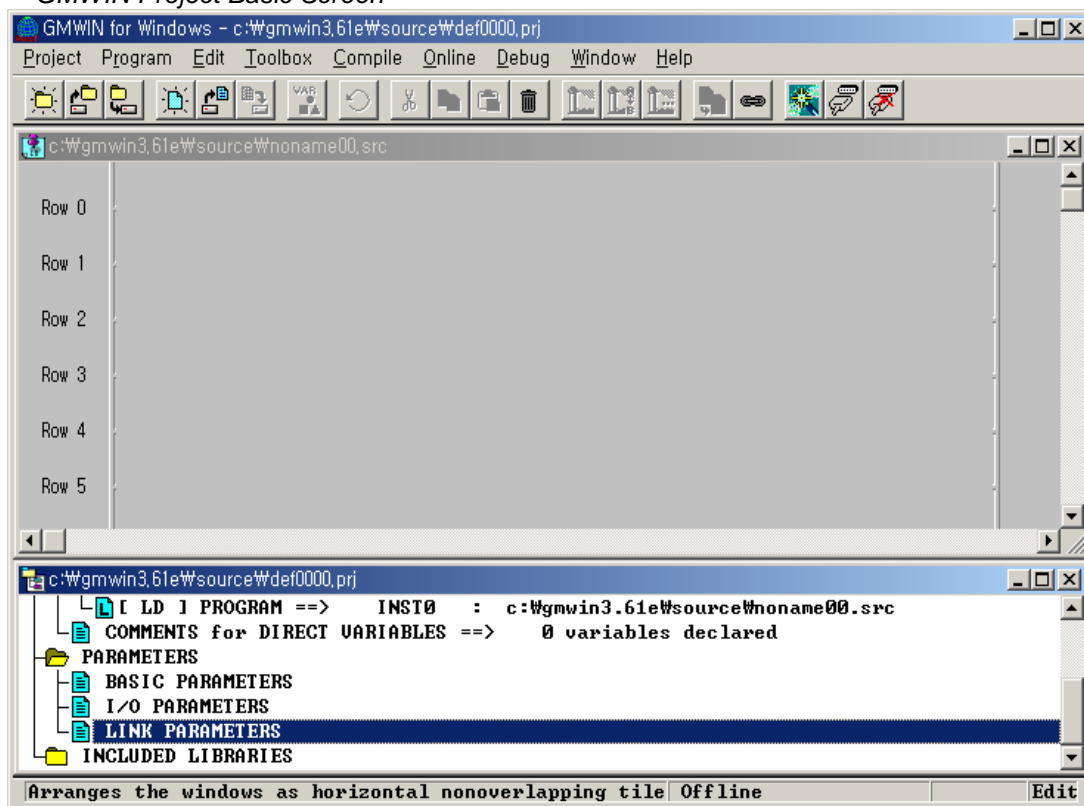

2) Link Parameter Selection

(1) Setting method : select parameter-*High Speed Link* parameter from project screen.

GMWIN High Speed Link Parameter

Chapter 4 Communication Programming

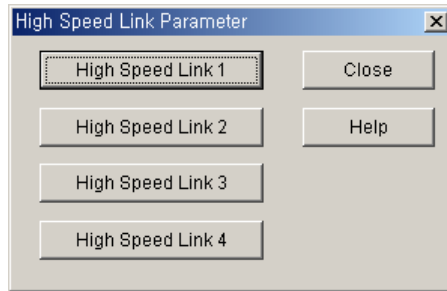

- (2) Setting function : GMWIN *High Speed Link 1~4* items means max.installation no. of communication module by master PLC CPU type.
- A) If the using communication model is only one, select *High Speed Link 1*.
 - B) One *High Speed Link* parameter is available to set only for one communication module.

3) Link Parameter Setting

If selecting the corresponding parameter from parameter setting basic screen, *High Speed Link* parameter setting window will appear and when setting the parameter first, the initial value will be indicated as below.

GMWIN Parameter Setting Initial Screen

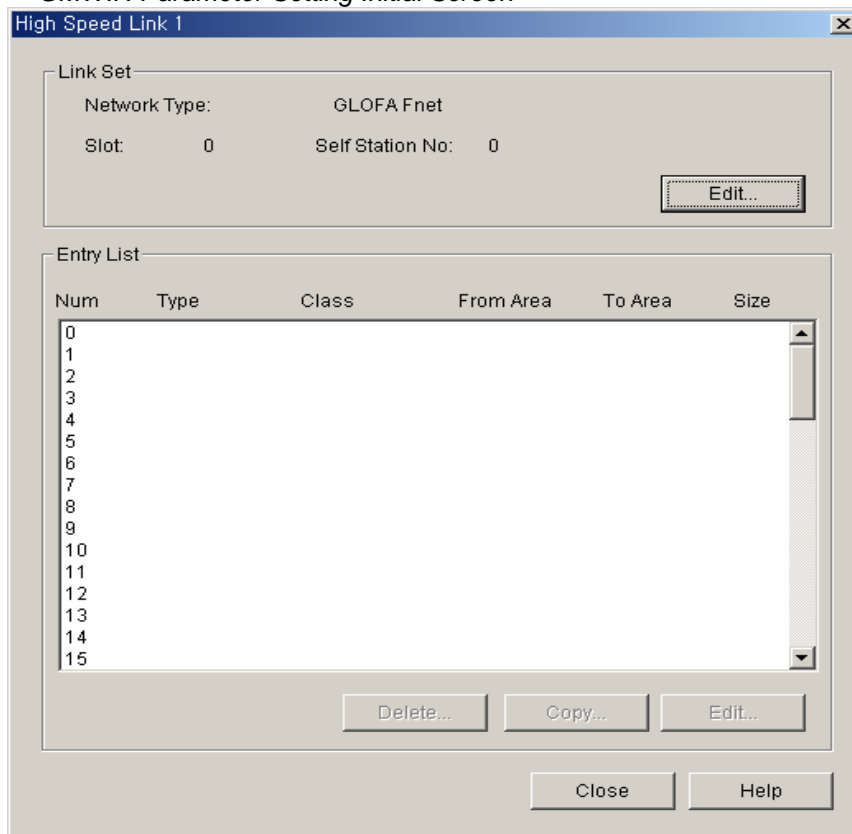

Parameter setting initial screen is composed of two items such as "Link set" and "Entry list" and the setting methods per each item and its function are as follows.

(1) Link Setting

Chapter 4 Communication Programming

Link setting is the item to set the basic articles of communication module to carry out *High Speed Link*.

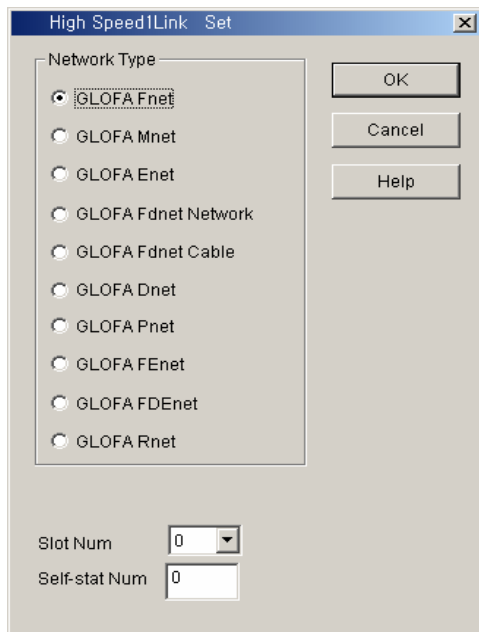

Network type : this is to set the type of communication module and select according to the installed communication module model type.

Slot number : set one of 0 ~7 for slot number that communication module is mounted(the right side of CPU module is "0" slot).

Own station number : enter its own station no. that is set on the station no. switch of communication module front side.

It is available to set 0~63 by decimal number. Self station number is unique number to distinguish communication module in the same network system, so doesn't use duplicated station number.

(Station num. '0' in Profibus-DP is reserved(can not be used). Refer to Chap.5)

(2) Entry List Setting

Entry list is the area to register the actual sending/ receiving data information. Set the registration no. from '0' of registration list area first and place the cursor on the desired position of number to set and double click or select 'Edit ...' button on the bottom of screen to set the corresponding contents in the *High Speed Link* item modification screen.

High Speed Link item modification screen

Chapter 4 Communication Programming

Example of sending parameter setting screen

Num	Type	Class	From Area	To Area	Size
0	Local0 Send0	D(200ms)	%MW0		4
1					
2					
3					
4					
5					
6					
7					
8					
9					
10					
11					
12					
13					
14					
15					

- **Entry List Num** : a serial no. indicating the order registred. Available to set 64 no.(from 0~63). Not related to the order of sending/receiving.
- **Station type** : this is the item to determine the type of other station to receive/send. Select remote type to communicate with Smart I/O.
- **Station no.** : In case that other station to communicate is local type, it is required to set the self station no. for sending and other station no. for receiving while in case of remote type, set other station no. all for sending/receiving. Thus, it is required to set the remote station no. when sending/receiving as Smart I/O series because it does not have parameter setting function in the remote station itself.

Chapter 4 Communication Programming

- **Mode** : this is the item to determine whether or not to send/receive data of the corresponding block. When receiving, select 'receive". The number of sending/receiving block is available to set max. 32 and if setting more than 32, the parameter error occurs and the normal communication does not work.

- **Block no.** : this is the parameter to send/receive lots of data of various area from one station and distinguish the data of various block each other. Generally, the station no. and block no. set by sending station is transmitted together with sending data and if the receiving station wants to receive this data, it is required to receive it as the corresponding block no. sent by sending station. The block no. of sending/receiving for one station is available to set max. 32 and it is not allowed to set the same block no. for the same station no. For remote station, it is set

differently regardless of sending/receiving.

- **Area** : after selecting data area to send/receive, enter the address direct and set the area.

Remote sending: read any data of the self station (designate one from %MW,%IW, %QW within the area to read) and designate which area of remote station is sent (%QW is only available to designate in the storage area. Remote sending data is available to send in the remote output side.)

Remote receiving: read any area of other remote station not the own station (%IW is only available to designate in the storage area. It is available to read the remote input data) and designate which position of the own station to save from %MW,%IW, %QW. As memory map is different according to CPU models, please refer to memory map described on the corresponding manual.

The following shows the setting available area according to station type.

Setting Area according to Station type

Remarks		Sending			Receiving		
		%IW	%QW	%MW	%IW	%QW	%MW
Remote	Area to read	○	○	○	○	X	X
	Storage area	X	○	X	○	○	○

○ :setting available X: setting not available

Remark

1) The address of Smart I/O series is allocated as %IW0.0.0 ~ %IW0.0.1 in case of input, and %QW0.0.0 ~ %QW0.0.1 in case of output.

- **Size** : data size to send/receive unit is 1 word (16 points).

Chapter 4 Communication Programming

- **Sending/Receiving period : High Speed Link** is the service to carry out the sending/receiving by the parameter set by the user at the point that PLC program ends. Thus, when PLC program scan time is short within several ms, communication module begins to transmit the data according to every program scan which result in increasing the communication amount and reducing the effectiveness of overall communication system. Thus, to prevent this, the user can set the sending/receiving period from min. 20ms to max. 10sec. If not setting, it shall be set as basic value of 200ms automatically. Sending/Receiving period means the sending period in case that the corresponding block is set as 'sending' and the data receiving check period of the corresponding block in case that it is set as 'receiving'. If PLC program scan time is longer than the setting sending period, it shall be sent at the point that PLC program scan ends and the sending period becomes to be equal to PLC program scan time.

Data Sending Delay Time (PLC program scan time > sending period)

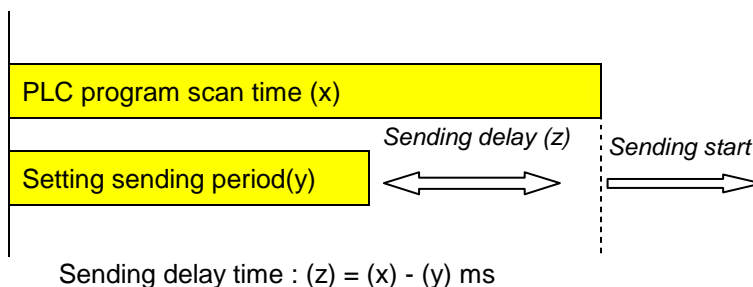

Data Sending Delay Time(PLC program scan time < sending period)

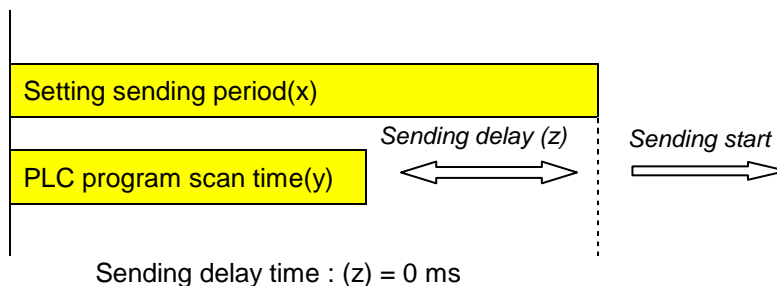

Remark

- 1) When setting the receiving period, the user can check if it is set as the value greater than the period of the corresponding block set by other station to receive normally.

4) High Speed Link operation

When *High Speed Link* parameter setting is completed, if the user execute 'make' from compile menu of GMWIN and then write parameter with PLC CPU and start the *High Speed Link* service and then *High Speed Link* service by parameter setting will begin. The start order of *High Speed Link* is as follows.

Parameter Write

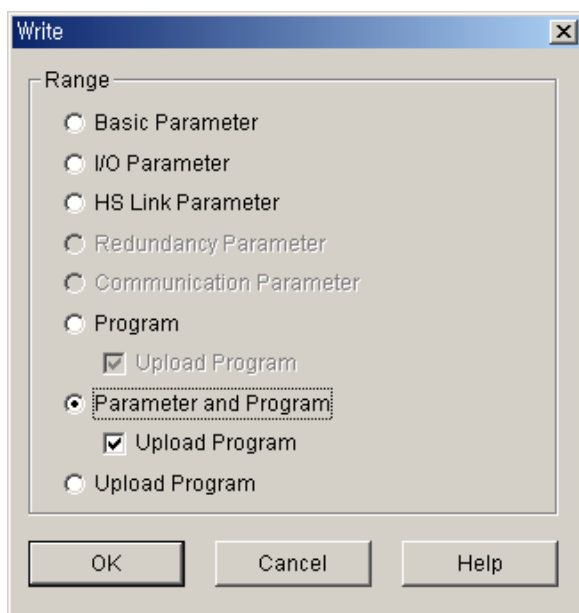

After saving *High Speed Link* parameter written by the user in GMWIN project file and connecting to PLC through 'online connect' of GMWIN basic menu, select 'write' and the window 'write' appears as above. If you select '*High Speed Link* parameter' or 'parameter and program' from the above menu and download the selected parameter, the corresponding contents shall be downloaded.

In this case, Link Enable which is *High Speed Link* start information shall be OFF. Therefore User has to click on the appropriate item of *High Speed Link* in link Enable setting.

5) High Speed Link start

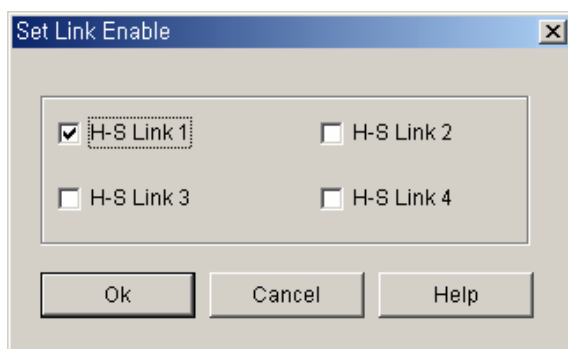

Chapter 4 Communication Programming

After 'parameter write', *High Speed Link* maintains all 'stop' but after the user sets Link Enable, *High Speed Link* runs.

'Set Link Enable' is available only for PLC stop mode. And if 'set *High Speed Link* Enable' starts, *High Speed Link* runs regardless PLC action mode and parameter and link enable information shall be preserved by having battery backup in PLC CPU even when power is off.

Relation of PLC mode and High Speed Link

Classification	Parameter download	Set Link enable	<i>High Speed Link</i> action	Remarks
PLC RUN	X	X	○	<i>High Speed Link</i> Only if allowed Act
PLC STOP	○	○	○	
PLC PAUSE	X	X	○	
PLC DEBUG	X	X	○	

4.2.5 KGLWIN Link Parameter Setting

In case of KGLWIN, its function is the same as that of GMWIN and its operating method and setting is also the same. Select 'link' from KGLWIN project menu and program it.

1) High Speed Link project setting

If selecting 'link' from Project menu, *High Speed Link* parameter basic screen will appear.

KGLWIN Project Basic Screen

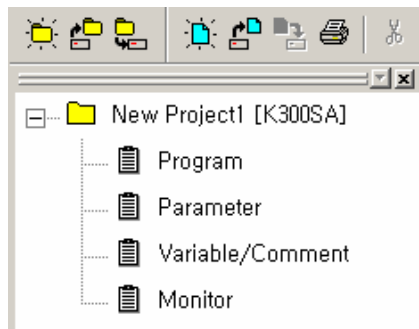

2) Link parameter selection

(1) Setting method : select 'parameter'-'link' from project screen.

KGLWIN Parameter menu

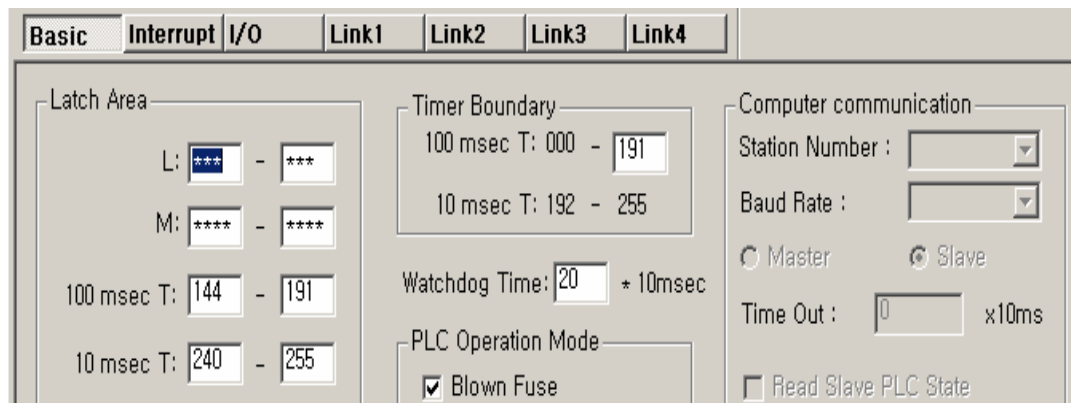

(2) Setting function : KGLWIN link 1~4 means max. Installation no. of communication module according to master PLC CPU types.

- A) If using one communication module, select link 1.
- B) Only one *High Speed Link* parameter is available to set for one communication module.

3) Link initial setting

KGLWIN contains all general contents necessary for communication setting in link items and the setting method is the same as that of GMWIN.

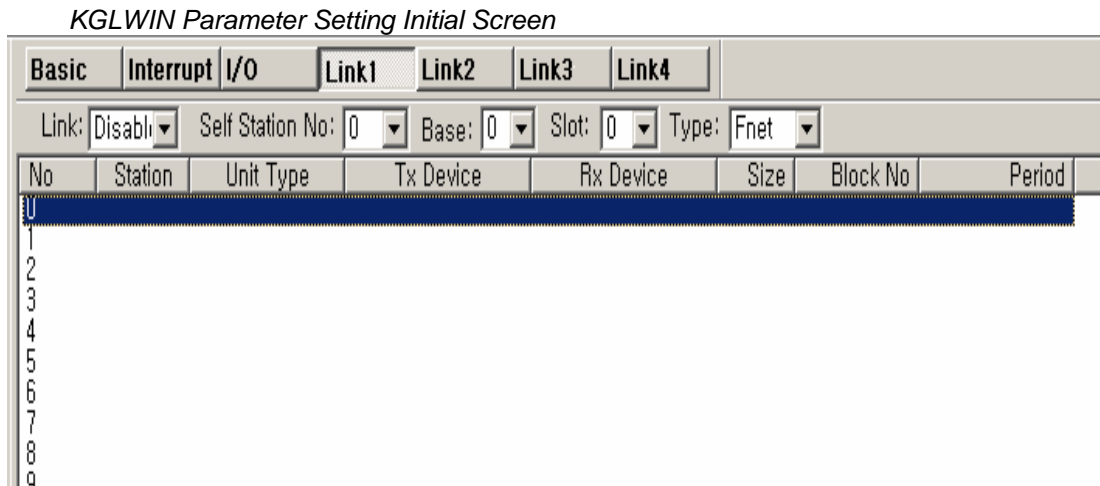

Parameter setting initial screen is composed of two items such as 'Link setting' and 'Entry list' and the setting method and function per each item is as follows.

(1) Link

Link is the Enable condition to carry out *High Speed Link* of the setting parameter.

Permit : High Speed Link is ON
Prohibit : High Speed Link is OFF

(2) Self Station no.

Enter its own station no. that is set on the station no. switch of communication module front side. It is available to set 0~63 by decimal number. Self station number is unique number to distinguish communication module in the same network system, so doesn't use duplicated station number.

(3) Slot

Set the slot no. that the desired communication module to set is installed by selecting one from the range of '0'~'7'.

(4) Type

Designate master communication type to communicate with Smart I/O module.

Rnet : Fieldbus communication module
Pnet : Profibus-DP communication module
Dnet : DeviceNet communication module

Chapter 4 Communication Programming

4) Link Setting Details

This is KGLWIN link item modification menu. If the user set the sending/receiving with the device to communicate actually, the parameter setting is completed.

- (1) Station no.
Sets the station no. of other station (remote station) to communicate with Smart I/O station.
- (2) Block no.
This is the parameter to be set to send/receive lots of data of various area from master and distinguish the data of various block each other. For remote station, it is set differently regardless of sending/receiving.
- (3) Communication type
This designates the communication method that master will carry out, and distinguish the communication type for local station and remote station..

Local sending : sets data sending between local stations
Local receiving : sets data receiving between local stations
Remote sending : sets data sending to remote station(Smart I/O).
Remote receiving : sets data receiving from remote station(Smart I/O).

- (4) Sending device/Receiving device
This means the area of sending/receiving and for setting, please refer to the table as below.

Classification	Mode	Setting available area	Remarks
Remote output	Sending	P, M, L, K, F, D, T, C all area	Sending area of its own station
	Receiving	P area	Receiving area of remote station
Remote input	Sending	P area	Sending area of remote station
	Receiving	P, M, L, K, D, T, C area	Receiving area of its own station

- (5) Size
Sets the size of sending/receiving data and the basic unit is **Word**.
(But, in case of **DeviceNet**, basic unit is **Byte**.)

Chapter 4 Communication Programming

(6) Communication period

High Speed Link is the service to carry out the sending/receiving by the parameter set by the user at the point that PLC program ends. Thus, when PLC program scan time is short within several ms, communication module begins to transmit the data according to every program scan which result in increasing the communication amount and reducing the effectiveness of overall communication system. Thus, to prevent this, the user can set the sending/receiving period from min. 20ms to max. 10sec.

5) *High Speed Link* operation

High Speed Link in KGLWIN is performed automatically with the program download according to communication setting.

4.2.6 High Speed Link communication status flag information

1) High Speed Link information function

To confirm the reliability of data read from other station through *High Speed Link*, it provides the user with the method to confirm the *High Speed Link* service as *High Speed Link* flag information. It has individual information such as HS_STATE, TRX_STATE, DEVICE_MODE, ERROR that informs the communication status per 64 registration items in the flag of run-link, link-trouble and parameter that informs the overall status of *High Speed Link*. The user can utilize the above information by combining with *High Speed Link* sending/receiving data as keyword type when writing the program in case of emergency or maintenance.

High Speed Link information

Classification	Run-link	Link-trouble LINK_ TROUBLE	Sending/ receiving status TRX_MODE	Action mode DEV_MODE	Error DEV_ERROR	High Speed Link status HS_STATE
Information type	Overall information	Overall information	Individual information	Individual information	Individual information	Individual information
Keyword name (□=HS link no. 1,2,3,4)	_HS□RLINK	_HS□LTRBL	_HS□TRX[n] (n=individual parameter no.0~63)	_HS□MOD[n] (n=individual parameter no. 0~63)	_HS□ERR[n] (n=individual parameter no. 0~63)	_HS□STATE[n] (n=individual parameter no. 0~63)
Data type	BIT	BIT	BIT-ARRAY	BIT-ARRAY	BIT-ARRAY	BIT-ARRAY
Monitoring	Available	Available	Available	Available	Available	Available
Program	Available	Available	Available	Available	Available	Available

(1) Run-Link (_HS□RLINK)

This is the overall information that shows whether or not *High Speed Link* is running normally by the parameter set by the user. Once 'ON', it maintains 'ON' until link enable is 'OFF' and if the following condition is given, it shall be 'ON'.

- ① When link enable is 'ON'.
- ② when parameter registration list setting is set normally all.
- ③ when sending/receiving all data that corresponds with parameter registration list within the setting period.
- ④ when all other station status set in the parameter is 'RUN' and at the same time there is no error.

Chapter 4 Communication Programming

RUN-LINK ON condition

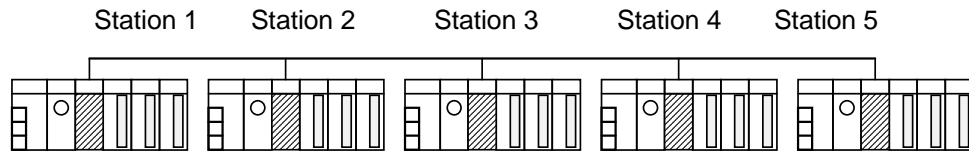

(a) *High Speed Link* system configuration

Station 1	Station 2	Station 3	Station 4	Station 5
Sending: 2words	Sending: 2words	Sending: 2words	Sending: 2words	Sending: 2words
Receiving: 2word (station 2)	Receiving: 2word (station 1)	Receiving: 2word (station 1)		
Receiving: 2word (station 3)	Receiving: 2word (station 4)	Receiving: 2word (station 5)		

(b) Examples of *High Speed Link* parameter setting of each station

The figure shows *High Speed Link* system configuration to explain RUN-LINK ON condition. In case that 5 communication modules are connected by network as shown (a) of the figure and carry out *High Speed Link* as the content of parameter of figure (b), RUN-LINK ON condition of Station 1 is as follows.

- ① when in the self station (station 1), Link-Enable is 'ON',
- ② when the self station (station 1) is RUN status,
- ③ when the self station (station 1) is not the error status,
- ④ when the sending parameter data set in the self station (station 1) is sent properly for the sending period,
- ⑤ when the data receiving from station 2,3 is received properly for the receiving period,
- ⑥ when the action mode of other station (station 2, 3) to send the data to the self station (station 1) is RUN mode and not the error status and it is communicated properly for the sending/receiving period,
- ⑦ when in the other station (station 2,3) of the self station (station 1), the action mode of other other station (station 4,5) set in the parameter is RUN mode and not the error status and it is communicated properly for the sending/receiving mode.

If the above 7 items are satisfied, RUN-LINK of station 1 shall be ON. If using RUN-LINK contact associated with program in the system where PLC of various stations performs interlocking through *High Speed Link*, it is available to carry out the mutual monitoring of sending/receiving data and the reliable communication. But, once RUN-LINK contact is 'ON', it maintains 'ON' status until Link-Enable becomes 'OFF'. Thus when monitoring the abnormal status such as communication error, it is required to use link trouble

Chapter 4 Communication Programming

information contact together as follows.

(2) Link-Trouble (`_HS□LTRBL`)

When RUN-LINK violates the condition of RUN-LINK ON in the status that RUN-LINK is ON, LINK-TROUBLE shall be 'ON' and if recovered, it shall be 'OFF'.

(3) Sending/Receiving status (`_TRX□STATE[0..63]`)

When the parameter action that is set in the individual parameter registration no.(0~63) respectively, is carried out properly in accordance with sending/receiving period, the corresponding bit shall be 'ON' and if not carried out, it shall be 'OFF'.

(4) Action mode (`_HS□MODE[0..63]`)

It describes the parameter action mode information that is set in the individual parameter registration no.(0~63). If the station set in the registration item is RUN mode, the corresponding bit shall be 'ON' and if STOP/PAUSE/DEBUG mode, it shall be 'OFF'.

(5) Error (`_HS□ERR[0..63]`)

It describes the parameter error information that is set in the individual parameter registration no.(0~63). The error indicates generally the status that the PLC does not work the user program normally and if it is 'OFF', this means that the PLC of other station works normally and if 'ON', this means that the other station is in the abnormal status.

(6) *High Speed Link* status (`_HS□STATE[0..63]`)

It describes the general information for registration list by collecting all individual information per item. That is, if the sending/receiving status of the corresponding list is normal and the action mode is RUN and there is no error, it shall be 'ON' and if violating the above condition, it shall be 'OFF'.

Remark

Among the keywords used in (1)~(6) items

□: : describes *High Speed Link* no.(1,2,3,4) used when setting the parameter.

(if the installed communication module is one, *High Speed Link* 1 shall be used.)

[0...63]: describes individual parameter registration no.

(check the communication status of each parameter that is in the registration no.0~63.)

Remark

Chapter 4 Communication Programming

1) In case of Profibus-DP module, it has other *High Speed Link* flag. For further information, please refer to '5.3.12 GMWIN *High Speed Link* information'.

4.2.7 High Speed Link Speed Calculation

1) Overview

High Speed Link data transmission speed can be determined by various factors.

Data transmission from one communication station to another communication station shall be performed through the following path.

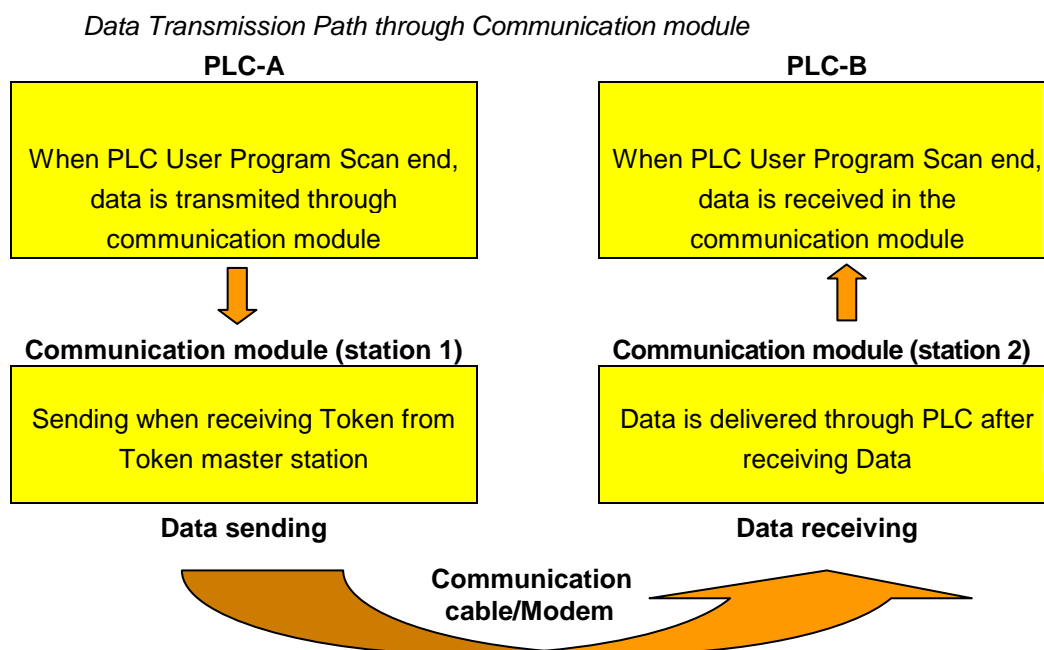

As shown on the above figure, there are 3 kinds of path to send data to other station through communication module and the sum of time to take for each path determines the sending time.

The table below describes the major path of data transmission and the factor that influences the transmission time per path.

Data Transmission Path and Time Factor

Path	Time factor
PLC CPU(A) --> communication module (station 1)	PLC-A program scan time
Communication module (station 1) --> Communication module (station 2)	Communication scan time + Communication O/S scan time
Communication module (station 2) --> PLC CPU(B)	PLC-B program scan time

Chapter 4 Communication Programming

As data delivery between PLC CPU and communication module is executed at the point when the user program of PLC ends, program scan time shall be major factor of data transmission. Program scan time monitor can know the current program scan time

from program tool. And as data sending/receiving is carried out after obtaining the Token from communication module which allocates tokens so that communication module sends its own data, this time also is included in the communication delay time.

The following figure shows PLC program scan time and the sending point according to communication scan time.

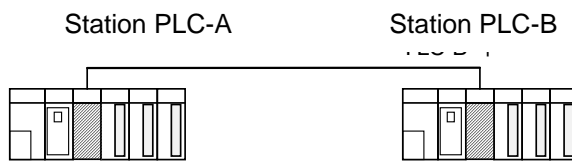

Relation of PLC scan time and Communication scan time

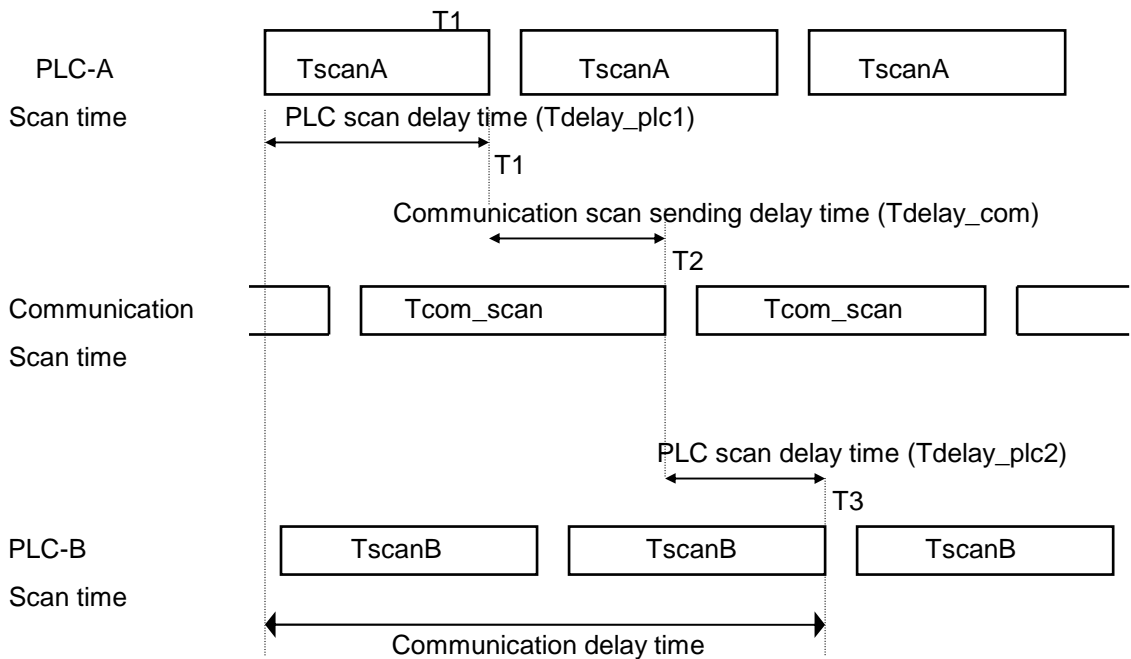

From the above figure, total communication delay time is $T_1 + T_2 + T_3$.

As above, communication delay time shall be determined by various variables such as total no. of communication station, program size and O/S scan time of communication module. As these variables are difficult to calculate its value, we recommend the example of simple *High Speed Link* communication speed as follows.

2) High Speed Link speed calculation method

High Speed Link speed shall be calculated with maximum time to take to send one block data from PLC-A to PLC-B by using the above figure as an example. As communication delay time is different according to the no. of overall communication station and program size, we divide into two cases such as complicated system that the sending data no. to more than 10 communication station exceeds total 512 bytes and the simple system less than 512 bytes and calculate *High Speed Link* speed as follows.

(1) Simple system

In the system that total communication station is below 10 stations and total sending data size is less than 512 bytes, you can calculate *High Speed Link* speed by using the following formula.

$$St = P_scanA + C_scan + P_scanB \text{ -----[formula 4-1]}$$

$St = \text{High Speed Link max. Transmission time}$

$P_scanA = \text{PLC A max. Program scan time}$

$C_scan = \text{max. Communication module scan time}$

$P_scanB = \text{PLC B max. Program scan time}$

Each item shall be determined as follows.

$$\textcircled{1} C_scan = THT \times Sn \text{ -----[formula 4-2]}$$

THT = Token Hold Time : Token use time per one station

Sn = Total Station Number : Total communication station number

$$\textcircled{2} \text{Token Hold Time (THT)} = Fnet : 8 \text{ ms}$$

(2) Complicated system.

In the system that total communication station is more than 10 station and total sending data size is more than 512 bytes, you can calculate *High Speed Link* speed by using the following formula.

$$St = Et \times To \times Ntx + Mf \text{ -----[formula 4-3]}$$

Chapter 4 Communication Programming

Et = Effective Tx Ratio (Effective transmission Ratio)

To = Octet time (1 byte sending time)

Ntx = Total Tx number

Mf = Margin Factor

Each item shall be determined as follows.

① $Et = Sn \times Nf$ -----[formula 4-4]

Sn = Total communication station number

Nf = network factor and constant number value according to the communication system characteristic. In Fnet system, it is 1.5

② To = Octet Time. The time to take to transmit one byte data to the serial data.

- Fnet : 8 μ s

③ Ntx = total sending data number including *Function Block*/command number and it is determined according to Fnet system as follows.

- Fnet : sum of *High Speed Link* sending byte number + Variable F/B(command) number $\times 256$

④ Mf = margin value for the factors not described like the above formula such as O/S scan time of communication module. Fnet is set as the following value.

- Fnet : 16 ms

4.3 Function Block

4.3.1 Overview

Function Block is the function to write or read the specific data of the self station or the specific variable data in the specific area or specific variable area of other station when the regular event occurs, and it can be used diversely according to the purpose.

Program of Smart I/O series using the *Function Block* is limited all in Modbus Snet. For further information, please refer to 'Chapter 8. Modbus communication'.

4.3.2 Start of GMWIN *Function Block*

When programming by using *Function Block*, please refer to the following. *Function Block* carries out the variable setting by input section and output section and for the setting method, please refer to the corresponding *Function Block*.

It describes based on GLOFA GM7 *Function Block*.

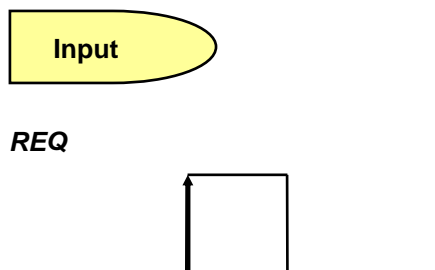

This is used as the start condition of modebus *Function Block* and it starts at the rising edge from '0' to '1'. Once started, *Function Block* is not influenced until receiving the response from other station. After setting NDR or ERR bit, it shall be reset in next scan.

SLV_ADDR :

This sets the remote station number to communicate by performing this *Function Block*.

FUNC :

This enters modbus function code. For further information, please refer to 'Chapter 8 Modbus Communication'.

ADDRH :

This designates the starting address and middle/high address among the starting

Chapter 4 Communication Programming

address to read in remote station.

ADDRL :

This designates the low address among the starting address to read in remote station.

NUMH :

This designates the high address of data size to read from starting address in remote station.

NUML :

This designates the low address of data size to read from starting address in remote station.

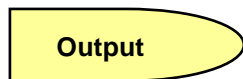

NDR :

After *Function Block* starting, if data receiving is OK, it shall be 'ON' and when the corresponding scan ends, it shall be 'OFF'. If using this bit as other *Function Block* input condition, it is available to carry out the reliable communication.

ERR :

After *Function Block* starting, if error occurs, it shall be 'ON' and maintains 'ON' until the next *Function Block* starts again and then 'OFF'. If error occurs, it is not available to receive the data.

STATUS :

It describes the detailed code value for the error when error occurs after starting *Function Block* and maintains the value until the next *Function Block* starts again and then 'OFF'.

Remark

Chapter 4 Communication Programming

Requirements of Function Block

- 1) *Function Block* requirements (REQ) start shall be executed after the previous execution is completed normally (after 'NDR' ON).

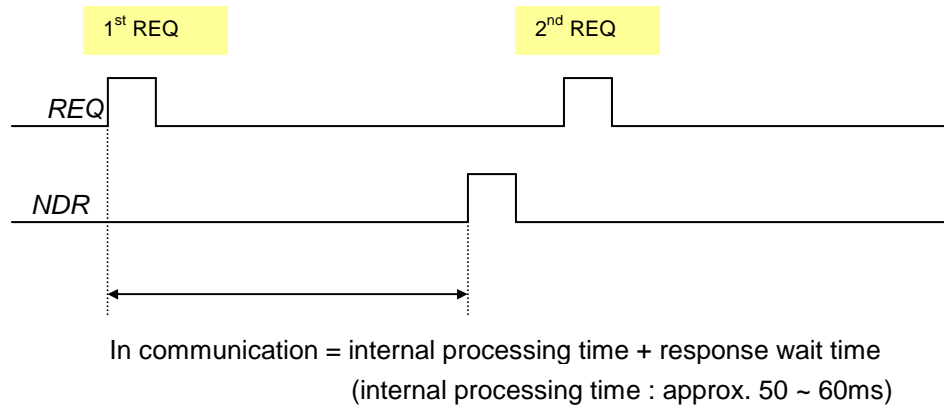

4.3.3 Execution of KGLWIN command

MASTER-K command executes the programming by using KGLWIN Modbus command. Please refer to the command execution method and available address area. (Refer to Chapter 8.4.2 Modbus communication-MASTER-K series)